

COOPER[®]

Split-to-the-shaft **roller bearings**

PRODUCT CATALOG



an SKF Group brand

SKF

INTRODUCTION

As a company that has been established for over 100 years, Cooper Bearings Group has a worldwide presence, with sales offices in the UK, USA, India and Germany. With unrivalled experience and expertise within our field, across the globe, we know we offer the best solution.

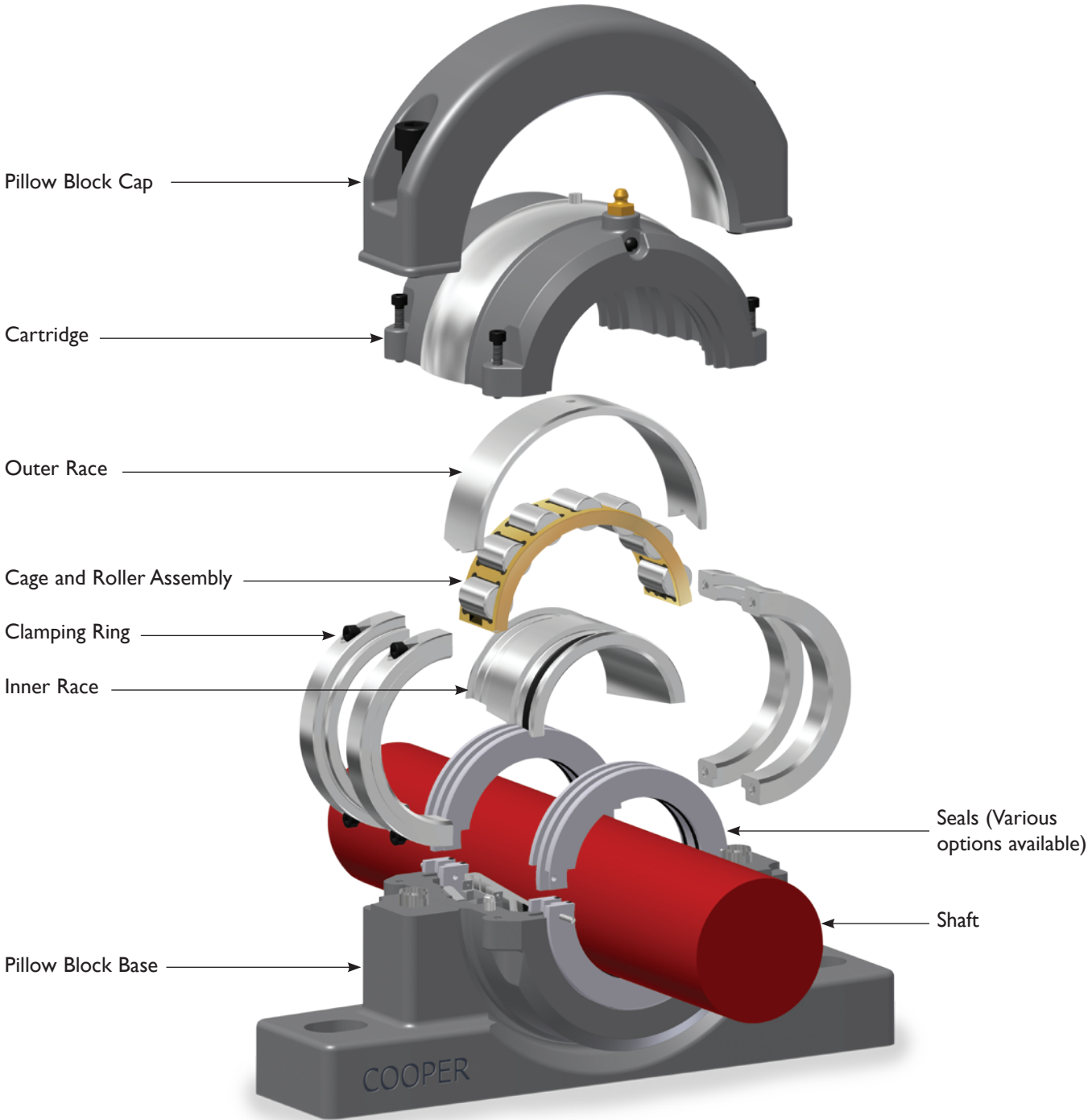

WHAT IS THE SOLUTION?

We provide totally split to the shaft roller bearings with totally split to the shaft components. Every Cooper component including bearing & cage assemblies, cartridges, pedestals, inner and outer races and our triple labyrinth seals are split to the shaft for easy installation.

And, if we don't already make it, our skilled Engineers can work with you to produce a custom made split roller bearing solution to solve your unique application problem.

Ease of installation and maintenance makes the Cooper bearing an ideal solution for any application.

WHY SHOULD YOU CARE?

With competition growing within your industry and margins being continually squeezed, we understand that for you and your customers achieving performance gains and running existing equipment to its full potential is increasingly important to stay ahead. We know that you or your customers can't afford lost (or loss of) production time due to machinery downtime, whether it's at scheduled maintenance times or through failures.

The Cooper Bearings Group is always striving to provide you and your customers with the best value engineered products and solutions that will meet or exceed your needs.

There is one proven answer to reducing production loss and machinery downtime expenses.

That is the use of Cooper split roller bearings.

IS A SPLIT REALLY THE ANSWER?

Are you looking for a bearing solution that offers a longer bearing life?

In comparison to a solid bearing, Cooper split roller bearings are often better adapted to the sometimes harsh environment they are required to work in. The superior sealing of the Cooper triple labyrinth seal retains lubrication and keeps contaminants from entering the bearing assembly, providing a longer bearing life.

Are you looking for a bearing solution that is easy to install and maintain?

In comparison to a solid bearing, where trapped locations are involved, Cooper split roller bearings are easier to install, inspect and maintain.

Other equipment on the shaft, such as pumps, motors and gearboxes that may be on either side of a bearing, does not need

to be removed for bearing replacement to take place. Due to the totally split components installation inspection and maintenance can be performed at a cost saving.

Finally, do you want a bearing solution that isn't going to cost a fortune?

The Cooper split roller bearing reduces production downtime and reduces installation expenses as well as reducing power consumption.

When the working life of a Cooper bearing is taken into account, the Cooper bearing is an extremely attractive investment.

So if you're tasked with increasing efficiency and cost savings, it's job done with a Cooper split roller bearing!

In the long run, Cooper offers a far more profitable solution compared to a solid, with far greater flexibility in design, ease of inspection, installation and maintenance solutions all without compromising performance.

SERVICE SECOND TO NONE

Cooper's ability to resolve customers needs through the technical skills and resources of our in-house Engineering team and our strong customer service and field support teams, or through our established network of skilled supply-chain partners is a key component to our success.

Cooper Bearings Group offers a range of services that can provide solutions to your specific bearing questions, conditions and problems.

- Our Engineering team can resolve technical issues rapidly and accurately addressing your maintenance and design needs
- Remanufacture & Repair services provide an economical solution to replacing with new
- Customer Service & Sales Specialist working to provide customers with solutions
- Emergency after-hours support available
- E-Business technology through distributor support on PTplace. Price & availability look-up 24/7
- Product Training tailored to your audience offered at your location

Cooper Bearings Group is dedicated to our customers by supplying service offerings with solutions that provide operational efficiency and cost reductions that maximise uptime and performance with proven results and customer value.

CONTENTS

3	Overview of nomenclature	112	Take-up units
4-7	Bearing types	113-117	Inch size take-up push-type units
8	Bearing mounting options	118-123	Inch size take-up tension-type units
9	Comparison of series	124-129	Metric take-up push type units
10	Joint gaps and internal clearances	130-131	Metric take-up tension type units
11-13	Bearing selection	132	Rod-end bearing units
14-19	Radial load carrying capacity	133-137	Inch - size rod - end bearing units T type
20-21	Shaft tolerance and journal dimensions	138-142	Inch - size rod end bearing units Shoe type
22-24	Vibration data	143-145	Metric rod - end bearing units T type
25-27	Sealing solutions	146-149	Metric rod end bearing units Shoe type
28-29	Blanking plates	150-151	Bearings over 24"/600mm bore size
30-33	Lubrication	152	04 Series bearings
34-35	Standard bearings cartridges and pillow block to 24"/600mm bore size	153	Water-cooled bearings for continuous casters
36-53	Inch-size bearings, cartridges and pillow blocks	154	Special products
54-73	Metric bearings, cartridges and pillow blocks	155	Split tapered bearings introduction
74-75	Marine specification pillow blocks	156	Bearing selection
76-82	Compatible pedestals	157	Assembly - Grease quantity for initial lubrication
76	Type E compatible pillow blocks	158	Routine greasing - Tightening torques
77	SAF compatible pillow blocks	159	Bearing data
78	SN compatible pillow blocks	160	Cartridge data
79-80	SD compatible pillow blocks	161	Tapered bearing pedestal units
81-82	Quick-Change™ compatible pedestals	162	Tapered bearing flange units
83-85	Flange - mounted units	Installation and assembly	
86-92	Inch-size round flange-mounted units	163-166	Assembly instructions
93-99	Metric round flange-mounted units	167-171	Screw sizes, wrench sizes and torques
100-101	Square flange-mounted units	172-176	Grease quantities for initial lubrication
102-103	Hanger bearing units	177-178	Routine greasing
104-107	Inch size hanger bearing units	179	What to do with your used bearing
108-109	Metric hanger bearing units	180-181	Troubleshooting guide
110-111	Triple boss hanger bearing units	182-185	Guidance on ordering and part codes

OVERVIEW OF COOPER NOMENCLATURE

PART DESCRIPTION: 01 BCP 507 EX ATL C3

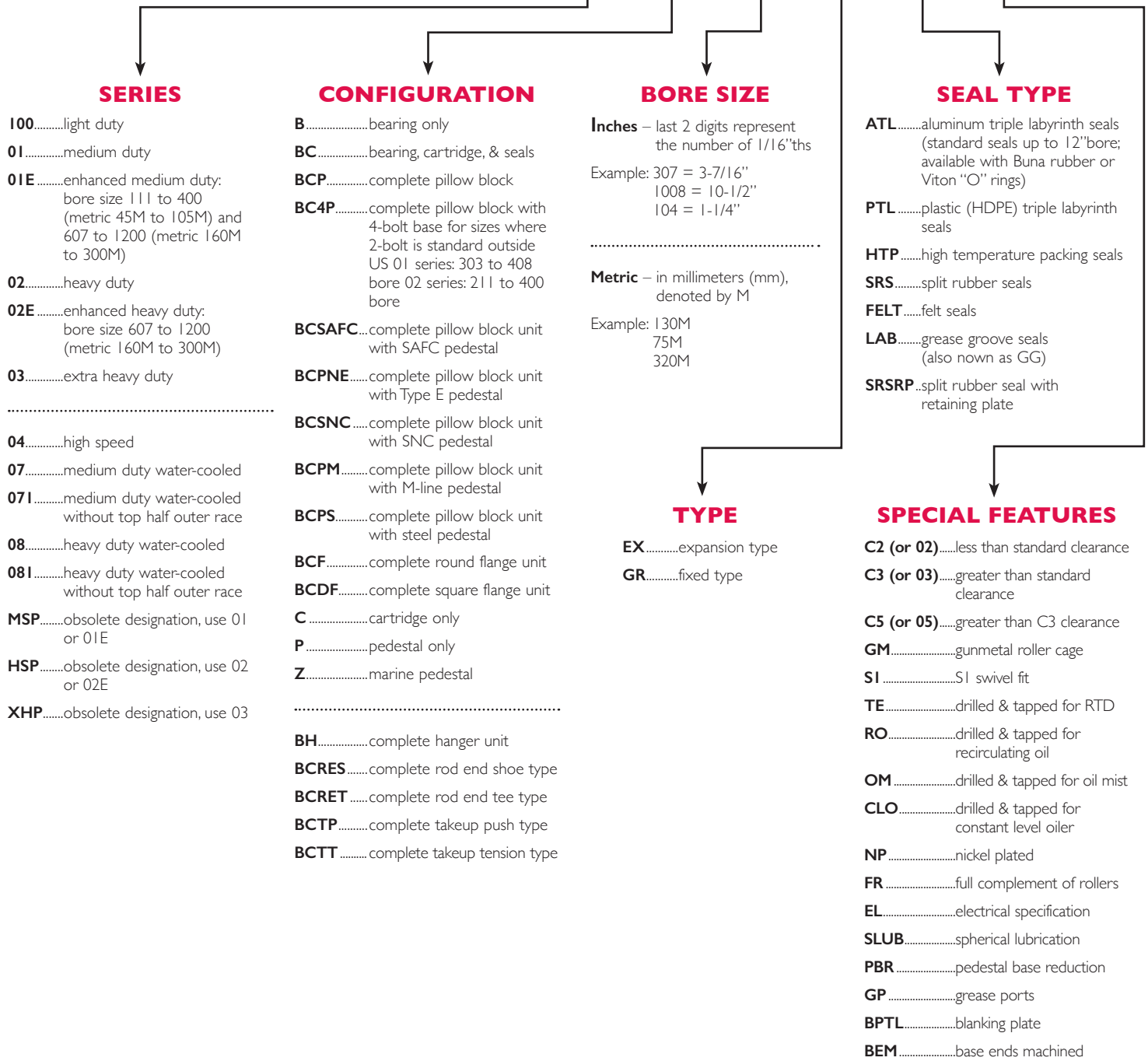

BEARING TYPES

Cooper bearings are commonly supplied in two forms: the Fixed Type ('GR') and Expansion Type ('EX') as described below. Where conditions are unsuitable for these standard types other configurations are possible, some of which are described on pages 5 to 7.

FIXED TYPE BEARINGS (GR)

The outer race of the fixed (GR) bearing has shoulders integral with the roller track, while the inner race assembly has shoulders formed by hardened lips on the clamping rings or similar integral shoulders.

This type of bearing provides axial location to the rotating

portions of machinery and can sustain both radial and axial loading.

The inner race halves are accurately aligned by means of fitted clamping rings.

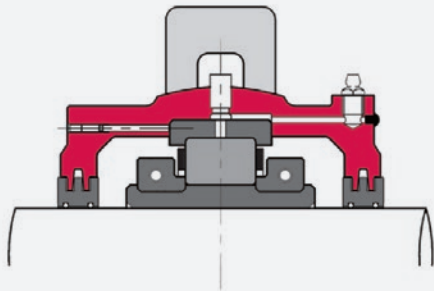

GR BEARING (D TYPE)

01 and 02 Series through 12"/300mm shaft size and 03 Series through 6"/155mm shaft size. 100 Series all shaft sizes.

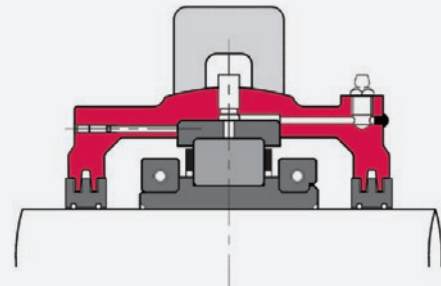

GR BEARING (C TYPE)

01 and 02 Series through 12"/300mm shaft size and 03 Series through 6"/155mm shaft size.

EXPANSION TYPE BEARINGS (EX)

The expansion (EX) bearing has a plain outer race roller track. This bearing takes radial load only.

The inner race is clamped to the shaft, and moves axially with it when expansion or contraction occurs.

The Cooper expansion bearing offers virtually no resistance to axial movement as the rollers spiral through the outer race.

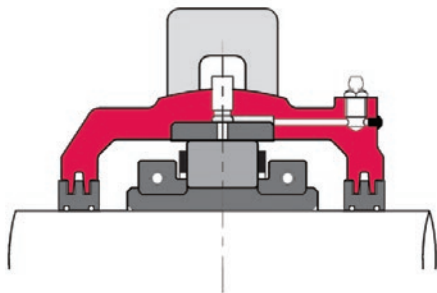

EX BEARING (D TYPE)

01 and 02 Series through 12"/300mm shaft size and 03 Series through 6"/155mm shaft size. 100 Series all shaft sizes.

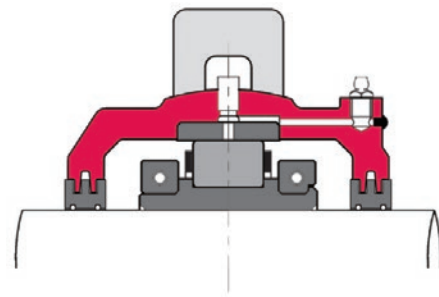

EX BEARING (C TYPE)

01 and 02 Series through 12"/300mm shaft size and 03 Series through 6"/155mm shaft size.

Here are some of the alternative configurations we are able to supply where the EX and GR types, shown on the previous page, are unsuitable. If you wish to specify one of these alternative

types, contact our technical department. Please supply details of your application, so we can insure the most suitable solution is provided.

GR BEARINGS WITH EXTRA AXIAL FLOAT (AF)

GR bearings can be supplied with the distance between the outer race lips increased to allow limited axial movement of the inner race and shaft.

For larger axial movements GROSL bearings may be required.

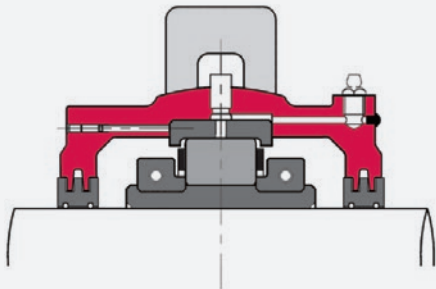

GR BEARING WITH EXTRA AXIAL FLOAT

SINGLE LIPPED BEARINGS (GROSL)

These bearings use a single lip on the outer race to locate the inner race and shaft in one direction only. There is usually clearance between the lip and rollers in the normal running position. Location in both directions is achieved by using two bearings, with lips facing in opposite directions.

Applications include electrical machinery. Here, paired GROSL

bearings are used to limit the movement of the rotor, which is allowed to float axially to run at its magnetic center.

Overall bearing dimensions are as standard GR & EX types. However, to achieve maximum axial movement, a slight offset between the centerlines of the inner and outer races may be required in the normal running position.

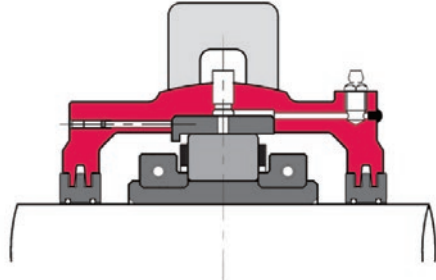
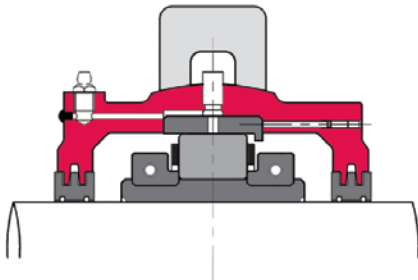

GROSL BEARINGS

EXPANSION BEARINGS WITH EXTRA AXIAL FLOAT (EXILOG)

Where the required axial movement of expansion bearings is greater than is possible with our EX type bearing a special type, with locating outer race and expansion type inner race, can be supplied.

With this type of bearing, the cage and rollers' assembly is located by lips on the outer race. The inner race is without lips, allowing

the rollers to spiral across it with virtually no resistance to axial movement. The inner race is generally wider than those in GR and EX bearings, in order to achieve the increased float.

Large axial movements may be present in applications where the shafts are subjected to large temperature fluctuations or where the shafts are very long.

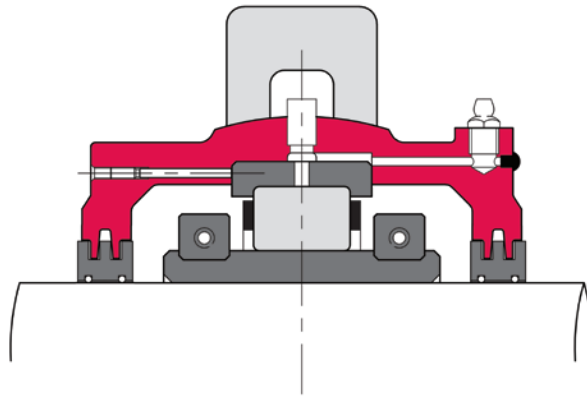

EXILOG BEARING

FULL ROW BEARINGS

For slow speed applications (up to approximately 5,900 dn(in), depending on size and series) we can supply cageless bearings with a full complement of rollers. These have the same overall dimensions as standard GR and EX bearings, but have higher

dynamic and static capacities. This may allow a lighter series of bearing to be selected (e.g. 01 Series instead of 02 Series) resulting in a more compact, and sometimes more economical solution.

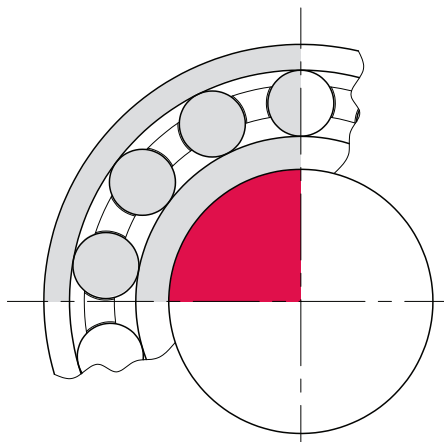

CAGED BEARING

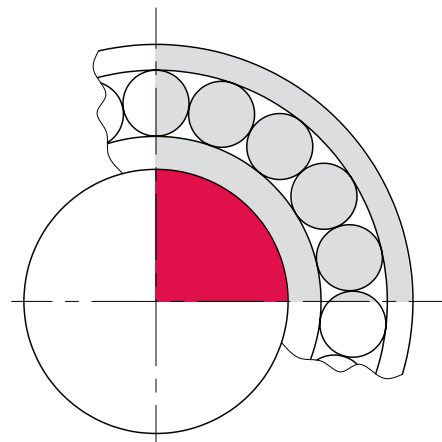

FULL ROW BEARING

DOUBLE BEARINGS

For increased radial capacity bearings may be supplied as matched pairs for mounting together to form two-row bearings. This is particularly applicable to bore sizes over 24".

Another application for double bearings is in link-spindle drives of all sizes, where double bearings are used to insure correct bearing alignment in a swivelling yoke supporting the center of the shaft.

Note: Bearings should only be mounted together to form a two-row bearing if they are supplied by Cooper specifically for this purpose.

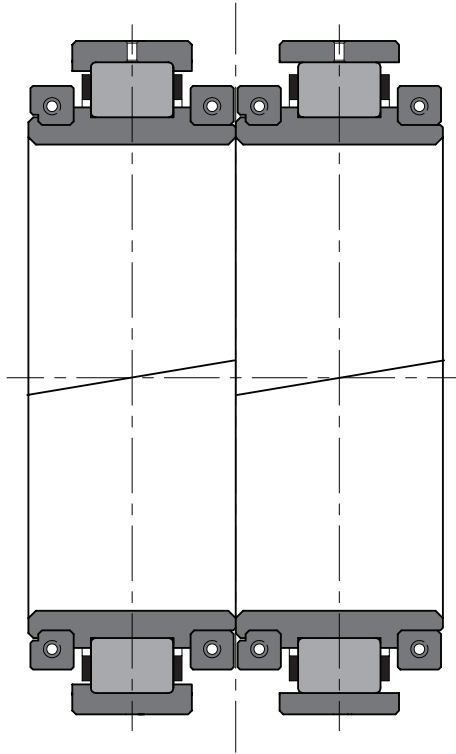

DOUBLE BEARING

Most styles of Cooper housing are available in cast iron, ductile iron or steel. Special types of housing, alternative materials and housings to special dimensions are available on request.

PILLOW BLOCKS

Pillow blocks (also called pedestals) are the most common mountings for Cooper bearings. Detail design and number of fixing bolts varies with bearing series and size.

Cooper offer ranges of pillow blocks that allow direct replacement of SAF, SN and SD pillow block units.



QUICK-CHANGE PEDESTAL



LARGE BORE BASE

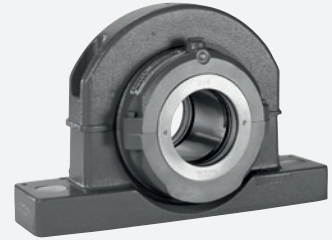

TWO BOLT BASE

WATERCOOLED HOUSINGS

Bearings in watercooled housings are designed primarily for use in steel mill continuous casters. The low profile housing is either cast or fabricated steel. For more information, please contact our technical department.

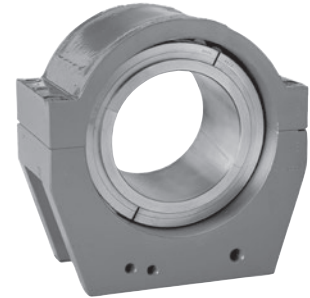

TAKE-UP AND ROD END MOUNTINGS

Take-up units are available as tension type (shown) or push type.

Rod-end units are available as shoe type (shown) or tee type.



TAKE-UP UNITS

| 3/16"/35mm to 6"/155mm



ROD END UNITS

| 3/16"/35mm to 6"/155mm

FLANGE MOUNTINGS



ROUND FLANGE UNITS

| 3/16"/35mm to 18"/460mm

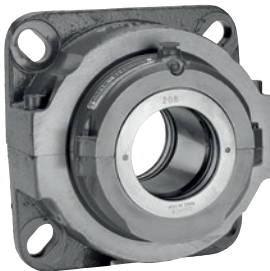

SQUARE FLANGE UNITS

| 1 1/16"/50mm to 3"/75mm



HANGER UNITS

| 3/16"/35mm to 5 1/2"/140mm

For most shaft sizes Cooper offers a range of three standard series:

01 Series for medium duties

02 Series for heavy duties

03 Series for extra heavy duties

In the range 1 11/16" to 4" the 01 Series is superseded by the 01E Series of increased capacity, but with matching envelope dimensions.

For certain bore sizes in the range 2 15/16" to 6" Cooper also offer the 100 Series. This has slightly lower capacity than 01 Series but is more compact and capable of higher speed operation.

The 04 Series is a specialized range of high speed bearings available in a restricted range of bore sizes from 6 inches to 1550mm.

Bearing references contain the series identification as the prefix numbers in the designation, e.g.:

01 B 415M EX

02 B 415M EX

are bearings of 01 & 02 Series respectively.

This catalog is laid out with 100, 01/01E, 02 and 03 Series listed together by bore size. This allows you to compare the capacity and speed capabilities, in order to select the most appropriate series.

Generally, if conditions allow and a satisfactory life is theoretically achieved by 01/01E bearings, this series of bearings is the most economical series to select. The 02/02E and 03 Series are successively higher rated, but are also more expensive in terms of first cost. If high speeds and/or restricted envelope dimensions preclude the use of 01/01E Series, the 100 Series should be selected if other conditions allow.

In the case of an existing bearing being replaced, there may have been other factors than just load capacity involved in the selection of the original bearing. It is often unnecessary to match load capacities of existing bearings to achieve satisfactory bearing life. Wherever possible, the loads on existing bearings should be assessed. This will insure the most appropriate and economical selection of Cooper bearings to replace them. Cooper can assist with this selection.

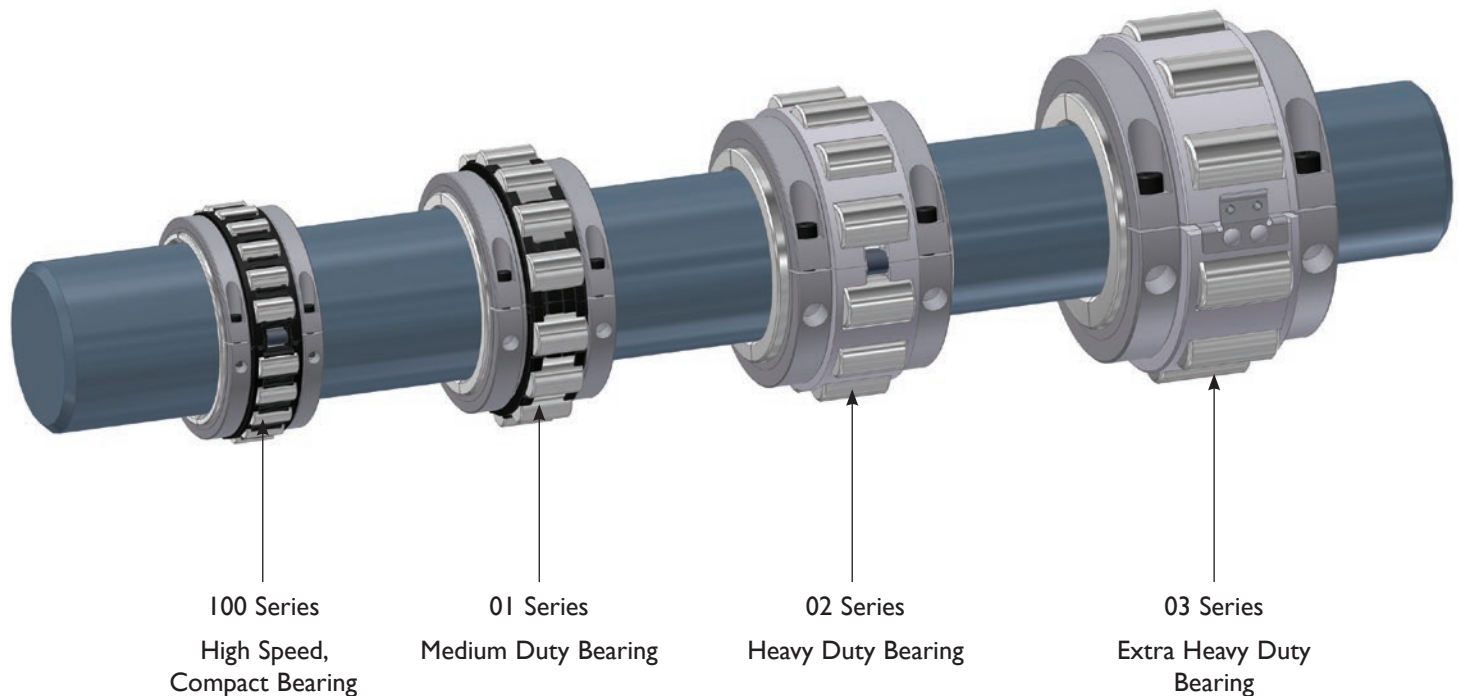

INNER RACE JOINT GAPS

When the inner race is assembled around a shaft, there should be a small gap at both joints. The gaps at the joints, typically between

0.015" and 0.025" per side, ensure contact between the bore of the inner race and the shaft. This is illustrated below.

SELECTION OF INTERNAL BEARING CLEARANCE

Cn represents the standard diametral clearance between the rollers and the outer race specified by the International Standards Organisation (ISO) and is usually adequate between -4° F and 212° F and when the temperature difference between the shaft temperature and the housing temperature is less than 72° F.

C2 clearance is less than standard and is used for reciprocating applications or when the shock loads and other conditions demand reduced clearance.

It is limited to a temperature difference of 30° F between shaft and housing temperature since high temperatures cause expansion of the bearing components.

C3 clearance is greater than standard and is typically used when

the difference between the shaft and bearing housing surface temperatures is between 72° F and 130° F.

C5 is typically the greatest clearance that Cooper offers. It is used when the difference between the shaft and bearing housing surface temperatures is greater than 130° F.

Cooper does not typically offer a C4 clearance.

Radial load ratings listed in this catalog are for standard clearance and C2 bearings. Bearings with C3 and C5 clearance have 5% and 10% lower capacity respectively.

For most industrial applications zero clearance is not desirable. Bearings will generate heat as they run. Without clearance, bearings may bind and fail prematurely.

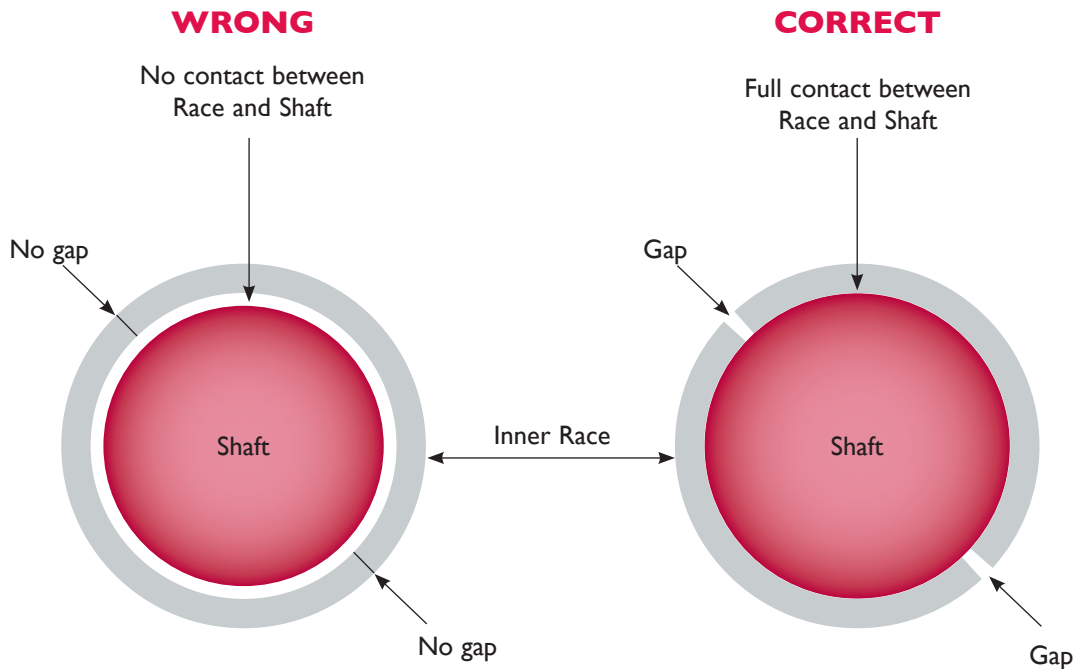

BEARING SELECTION

Selection of Cooper bearings must take into account both radial and axial loads, which are considered independently as the effect of the axial load on the radial load-bearing surfaces is small enough to discount at normal working loads and speeds.

The thrust or axial load is taken by the end face of the rollers and the flanged shoulders of the inner race assembly and outer race. The ability of the fixed (GR) unit to handle thrust loads is dependent upon specific pressure, velocity of contact areas and lubrication.

CALCULATING BEARING LOADS

The bearing loads are affected by one or more of the following:

1. Weight of components such as shafting, flywheels, sheaves, pulleys, gears, etc.
2. Tension resulting from belt or chain drives.
3. Tangential, separating and axial loading developed by gears.
4. Inertia loading resulting from acceleration or deceleration.
5. Centrifugal forces developed in rotary or out of balance motion.

SELECTION FOR RADIAL LOAD

The radial load ratings listed in this catalog are based on ISO standards. The system establishes a common basis for calculating load ratings for all anti-friction bearings. The radial load rating is denoted by Cr.

Selection for radial load is determined independently from the axial load. Determine the radial load, speed and minimum life required. Generally the shaft size has been predetermined. Selection of the bearing can be made using the following formula:

$$C_r \geq P \times f_n \times f_l \times f_d$$

Where Cr = radial dynamic rating.

P = calculated effective radial load.

f_n = speed (rpm) factor:

f_l = life (hours) factor:

f_d = dynamic or service factor:

$f_n = (\text{rpm} \times 0.03)^{0.3}$ or find from scale on page 13.

$f_l = (L_{10} \text{ hours}/500)^{0.3}$ or find from scale on page 13.

L_{10} hours is the expected life in hours of 90% of similar bearings under similar operating conditions.

Note: the product $f_n \times f_l$ should not be less than 1.0.

Alternatively, bearing life may be calculated by the equation $L_{10} = [Cr/(P \times f_d)]^{10/3}$, where: L_{10} = expected life of 90% of similar bearings under similar operating conditions, in millions of revolutions.

When the equivalent radial load equals the Cr rating, multiplied by the service factor, the L_{10} life will be 1 million revolutions.

If high temperatures (above 212° F) are involved, please refer to notes on page 13.

BEARING LIFE REQUIREMENTS (L)

Suggested lives and factors for specific operating conditions are shown below.

Operating Conditions	Life factor (fL)	Life hours (L ₁₀)
8 hour daily working	3.0-4.0	20,000- 50,000
Continuous operation main drives, large electrical machinery, flywheels, mining	4.4-5.0	70,000-100,000
Continuous operation and an exceptionally high degree of reliability	5.0-6.0	100,000-200,000

We recommend that bearings are specified to provide an L₁₀ life of at least 10,000 hours, except for bearings selected on the basis of static rating.

DYNAMIC FACTOR

The appropriate dynamic factor *f_d* may be taken from the chart below.

Conditions	<i>f_d</i>
Steady load or small fluctuations	1.0 - 1.3
Light shock	1.3 - 2.0
Heavy shock, vibration or reciprocation	2.0 - 3.5

LIFE ADJUSTMENT FACTORS FOR CRITICAL APPLICATIONS

The basic L₁₀ life obtained by using the equations or tables in this catalogue are adequate for normal applications.

Bearings for most normal applications are specified using the L₁₀ life as above. For reliability greater than 90%, replace L₁₀ in the above equations with L_{na} where L_{na} = a_l × L₁₀ and is given in the table below.

Reliability

%	95	96	97	98	99
a _l	0.62	0.53	0.44	0.33	0.21

MINIMUM RADIAL LOAD

The radial load must exceed a certain value in order to prevent the rollers skidding rather than rolling.

Cooper bearings are able to operate at lower loads than other types of rolling element bearings. Minimum radial loads are generally Cr/65 for GR bearings and Cr/120 for EX bearings. Lower loads can be accommodated under certain conditions. Please refer to our technical department.

BASIC STATIC LOAD RATINGS (C_{0R})

The values of C_{0R} given in this publication have been calculated in accordance with ISO standards. The basic static load rating is defined as that static (radial) load which corresponds to a contact stress of 4,000 MPa (580,000 psi) at the center of the most heavily loaded roller/raceway contact and produces a permanent deformation of 0.0001 times the roller diameter.

Where rotation is very slow (less than 5 rpm) or intermittent, bearing size can be selected based on the static load carrying capacity. The requisite basic static load rating can be determined from:

$$C_{0R} = S_0 \times P$$

where:

C_{0R} = basic static radial load rating (kN)

P = effective bearing load (kN)

S₀ = static safety factor

Bearing Static Safety Factors, S₀

Type of operation	Requirements for smooth running		
	Low	Normal	High
Vibration free	1	1.5	3
Normal	1	2	3.5
High shock loads	2.5	3	4

SELECTION FOR AXIAL LOAD

Selection for axial load is considered independently from the radial load. Determine the axial load applied to the bearing. Knowing the speed and desired shaft size, select a bearing using the following formula:

$$Ca > (fd_a \times fdn \times Pa) / fb$$

Where

Ca = axial rating

fd_a = dynamic or service factor

Pa = calculated axial load

fdn = velocity (dn) factor (see scale opposite)

fb = bearing factor (see scale opposite)

The dynamic or service factor fd_a may be 1 for peak overload periods and 1.1 to 1.2 for general running (depending on smoothness), where the load is accurately known. An allowance for any inaccuracies in the calculated loads must be made to insure that the bearing axial capacity is not exceeded.

Retaining rings or recessed journals are required when Pa > 0.5Ca for 01, 02 and 03 Series, if Pa > 0.25Ca for 01E and 02E Series, and if Pa > 0.2Ca for 100 Series bearings. See pages 20 and 21.

If the axial load exceeds 40% of the radial load, please consult our technical department.

The axial load capacity is decreased by 50% if the lubricant does not have extreme pressure (EP) additives.

TEMPERATURE

The normal range for standard bearings is 32° F to 212° F. Where the temperature rise is mainly from the shaft, increased diametric clearance may be necessary (see page 10).

Above 212° F, special consideration must be given to material, design, lubrication and seals. Above 248° F, special heat treatment of the bearing parts is required.

A reduction in radial capacity occurs at temperatures above (150° F) which can be seen below.

° F 338 392 482

% reduction 5 15 25

For temperatures above 212° F or below 32° F, please consult our technical department.

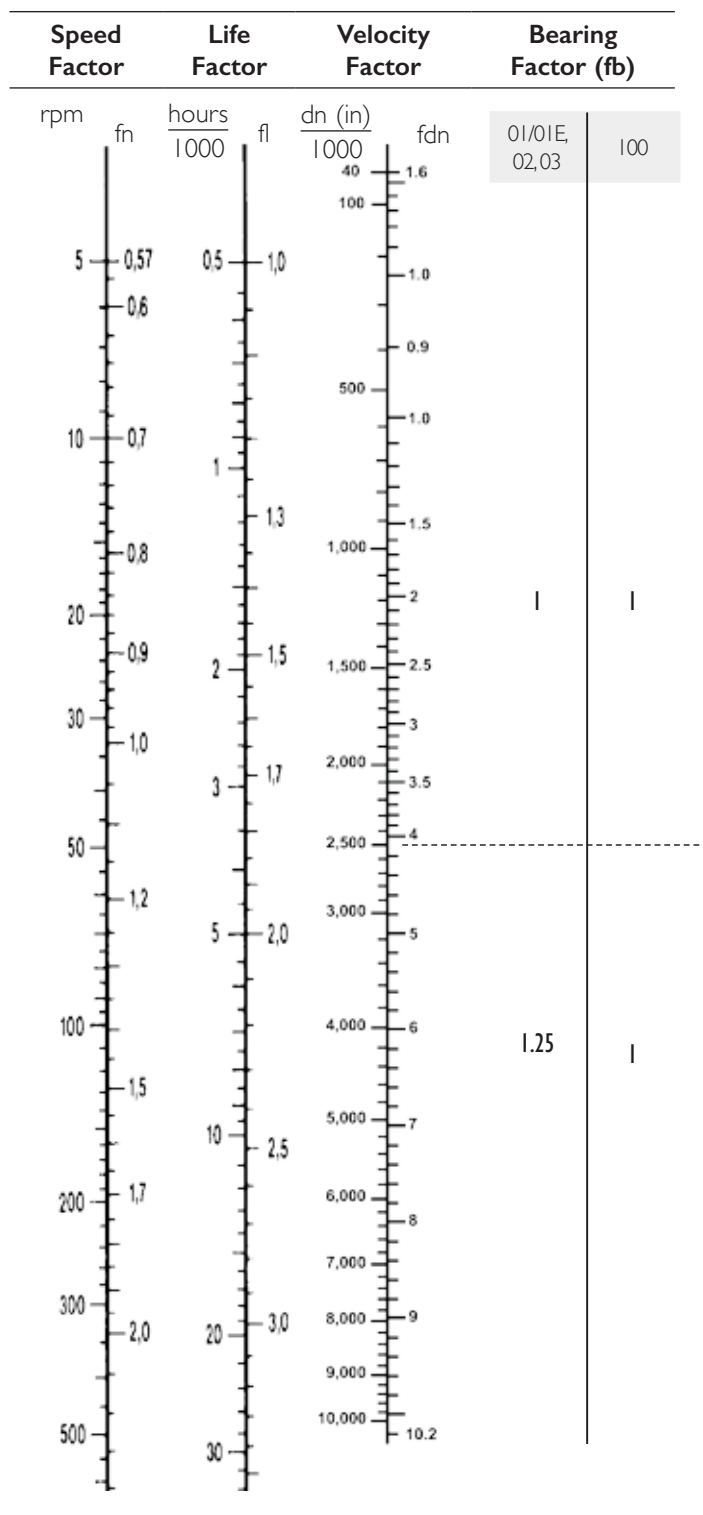

Velocity factor fdn applies only to axial loads on GR bearings.
dn (in) = bearing bore (in) x shaft speed (rpm)

RADIAL LOAD CARRYING CAPACITY QUICK REFERENCE TABLE

The table on the following pages is a rapid means of selection for radial load, based on a statistical fatigue life (L_{10}) of 30,000 hours at selected speeds. This life is often specified in general applications working approximately 8 hours per day.

No dynamic factor (f_d) is included in the values given. For most applications, the loads given should be divided by a dynamic factor as specified on page 12.

For 100,000 hours life, divide the loads in the table by 1.435, and then divide by the appropriate service factor.

The capacities shown in this table are for the bearing only. In most cases the load carrying capacity of the relevant housing exceeds the bearing capacity shown in this table, but should be checked by reference to the appropriate section of this catalog or confirmed by our technical department.

For a more detailed explanation of bearing selection, and for conditions not covered by this table, see page 11.

Fixed-type (GR) bearings carrying axial loads should be checked for axial load carrying capacity by reference to page 13.

Shaft Diameter d (in)	Reference	Bearing Ratings		Speed (rpm)											
		Cr (lb)	Max Speed (rpm)	50	100	200	400	800	1200	1500	1800	2000	2500	3000	3600
		Radial load capacity (lb) for 30,000 hours life													
1 3/16	01 B 103	15060	5400	3904	3171	2576	2092	1699	1505	1407	1332	1291	1207	1143	1082
1 1/4	1 B 104	15060	5400	3904	3171	2576	2092	1699	1505	1407	1332	1291	1207	1143	1082
1 7/16	1 B 107	15060	5400	3904	3171	2576	2092	1699	1505	1407	1332	1291	1207	1143	1082
1 1/2	1 B 108	15060	5400	3904	3171	2576	2092	1699	1505	1407	1332	1291	1207	1143	1082
1 11/16	01E B 111	21360	4630	5538	4498	3654	2968	2410	2134	1996	1890	1831	1713	1621	1535
1 3/4	01E B 112	21360	4630	5538	4498	3654	2968	2410	2134	1996	1890	1831	1713	1621	1535
1 5/16	01E B 115	21360	4630	5538	4498	3654	2968	2410	2134	1996	1890	1831	1713	1621	1535
	02 B 115	26750	4350	6935	5633	4575	3716	3019	2673	2500	2367	2293	2145	2031	1922
2	01E B 200	21360	4630	5538	4498	3654	2968	2410	2134	1996	1890	1831	1713	1621	1535
	02 B 200	26750	4350	6935	5633	4575	3716	3019	2673	2500	2367	2293	2145	2031	1922
2 3/16	01E B 203	30350	3940	7868	6391	5191	4217	3425	3033	2836	2685	2602	2433	2304	2181
	02 B 203	37770	3680	9792	7954	6460	5247	4262	3774	3530	3342	3238	3028	2867	2714
2 1/4	01E B 204	30350	3940	7868	6391	5191	4217	3425	3033	2836	2685	2602	2433	2304	2181
	02 B 204	37770	3680	9792	7954	6460	5247	4262	3774	3530	3342	3238	3028	2867	2714
2 7/16	01E B 207	30350	3940	7868	6391	5191	4217	3425	3033	2836	2685	2602	2433	2304	2181
	02 B 207	37770	3680	9792	7954	6460	5247	4262	3774	3530	3342	3238	3028	2867	2714
2 1/2	01E B 208	30350	3940	7868	6391	5191	4217	3425	3033	2836	2685	2602	2433	2304	2181
	02 B 208	37770	3680	9792	7954	6460	5247	4262	3774	3530	3342	3238	3028	2867	2714
2 11/16	01E B 211	37320	3310	9675	7859	6383	5185	4211	3729	3488	3302	3199	2992	2833	
	02 B 211	51480	3080	13346	10841	8805	7152	5809	5144	4811	4555	4413	4127	3908	
2 3/4	01E B 212	37320	3310	9675	7859	6383	5185	4211	3729	3488	3302	3199	2992	2833	
	02 B 212	51480	3080	13346	10841	8805	7152	5809	5144	4811	4555	4413	4127	3908	

Radial Load Carrying Capacity

Shaft Diameter (in)	Reference	Bearing Ratings		Speed (rpm)											
		Cr (lb)	Max Speed (rpm)	50	100	200	400	800	1200	1500	1800	2000	2500	3000	3600
		Radial load capacity (lb) for 30,000 hours life													
2 15/16	100 B 215	20460	4215	5304	4308	3500	2843	2309	2044	1912	1810	1754	1640	1553	1470
	01E B 215	4215	3310	9675	7859	6383	5185	4211	3729	3488	3302	3199	2992	2833	
	02 B 215	51480	3080	13346	10841	8805	7152	5809	5144	4811	4555	4413	4127	3908	
3	100 B 300	20460	4215	5304	4308	3500	2843	2309	2044	1912	1810	1754	1640	1553	1470
	01E B 300	37320	3310	9675	7859	6383	5185	4211	3729	3488	3302	3199	2992	2833	
	2 B 300	51480	3080	13346	10841	8805	7152	5809	5144	4811	4555	4413	4127	3908	
3 3/16	01E B 303	52600	2790	13637	11077	8997	7308	5936	5256	4916	4654	4509	4217		
	02 B 303	62940	2520	16318	13254	10766	8744	7103	6289	5882	5569	5396	5046		
3 1/4	01E B 304	52600	2790	13637	11077	8997	7308	5936	5256	4916	4654	4509	4217		
	02 B 304	62940	2520	16318	13254	10766	8744	7103	6289	5882	5569	5396	5046		
3 7/16	100 B 307	31920	4190	8275	6722	5460	4435	3602	3190	2983	2824	2736	2559	2423	2294
	01E B 307	52600	2790	13637	11077	8997	7308	5936	5256	4916	4654	4509	4217		
	2 B 307	62940	2520	16318	13254	10766	8744	7103	6289	5882	5569	5396	5046		
3 1/2	01E B 308	52600	2790	13637	11077	8997	7308	5936	5256	4916	4654	4509	4217		
	02 B 308	62940	2520	16318	13254	10766	8744	7103	6289	5882	5569	5396	5046		
3 11/16	01E B 311	71940	2340	18651	15149	12305	9995	8118	7188	6723	6365	6167			
	02 B 311	81380	2130	21098	17137	13920	11306	9184	8132	7605	7200	6976			
3 3/4	01E B 312	71940	2340	18651	15149	12305	9995	8118	7188	6723	6365	6167			
	02 B 312	81380	2130	21098	17137	13920	11306	9184	8132	7605	7200	6976			
3 15/16	100 B 315	42940	3090	11132	9042	7345	5966	4846	4291	4013	3799	3681	3443	3259	1535
	01E B 315	71940	2340	18651	15149	12305	9995	8118	7188	6723	6365	6167			
	02 B 315	81380	2130	21098	17137	13920	11306	9184	8132	7605	7200	6976			
	03 B 315	137100	1820	35544	28871	23450	19047	15471	13699	12812	12130				
4	100 B 400	42940	3090	11132	9042	7345	5966	4846	4291	4013	3799	3681	3443	3259	2181
	01E B 400	71940	2340	18651	15149	12305	9995	8118	7188	6723	6365	6167			
	02 B 400	81380	2130	21098	17137	13920	11306	9184	8132	7605	7200	6976			
4 3/16	01 B 403	68790	1970	17834	14486	11766	9557	7763	6874	6429	6086				
	02 B 403	102100	1820	26470	21500	17464	14185	11522	10202	9541	9034				
4 7/16	100 B 407	62790	2750	16279	13222	10740	8723	7086	6274	5868	5556	5383	5034	2304	2181
	01 B 407	68790	1970	17834	14486	11766	9557	7763	6874	6429	6086				
	02 B 407	102100	1820	26470	21500	17464	14185	11522	10202	9541	9034				
	03 B 407	138000	1640	35777	29060	23604	19173	15573	13789	12896					
4 1/2	100 B 408	62790	2750	16279	13222	10740	8723	7086	6274	5868	5556	5383	5034	2304	2181
	01 B 408	68790	1970	17834	14486	11766	9557	7763	6874	6429	6086				
	02 B 408	102100	1820	26470	21500	17464	14185	11522	10202	9541	9034				
4 1/2	03 B 408	138000	1640	35777	29060	23604	19173	15573	13789	12896					

Shaft Diameter d (in)	Reference	Bearing Ratings		Speed (rpm)											
		Cr (lb)	Max Speed (rpm)	50	100	200	400	800	1200	1500	1800	2000	2500	3000	3600
		Radial load capacity (lb) for 30,000 hours life													
4 15/16	100 B 415	62940	2480	16318	13254	10766	8744	7103	6289	5882	5569	5396			
	01 B 415	79800	1740	20689	16804	13649	11087	9005	7974	7458					
	02 B 415	123000	1600	31888	25901	2138	17089	13880	12290	11495					
	03 B 415	158700	1500	41144	33419	27145	22048	17909	15858	14831					
5	100 B 500	62940	2480	16318	13254	10766	8744	7103	6289	5882	5569	5396			
	01 B 500	79800	1740	20689	16804	13649	11087	9005	7974	7458					
	02 B 500	123000	1600	31888	25901	2138	17089	13880	12290	11495					
	03 B 500	158700	1500	41144	33419	27145	22048	17909	15858	14831					
5 3/16	01 B 503	88570	1570	22962	18651	15149	12305	9995	8850	8277					
	02 B 503	136700	1450	35440	28786	23382	18992	15426	13659						
5 7/16	100 B 507	74310	2250	19265	15648	12710	10324	8386	7425	6944	6575	6370			
	01 B 507	88570	1570	22962	18651	15149	12305	9995	8850	8277					
	02 B 507	136700	1450	35440	28786	23382	18992	15426	13659						
	03 B 507	199200	1340	51644	41948	34072	27675	22479	19905						
5 1/2	100 B 508	74310	2250	19265	15648	12710	10324	8386	7425	6944	6575	6370			
	01 B 508	88570	1570	22962	18651	15149	12305	9995	8850	8277					
	02 B 508	136700	1450	35440	28786	23382	18992	15426	13659						
	03 B 508	199200	1340	51644	41948	34072	27675	22479	19905						
5 15/16	100 B 515	89250	2060	23139	15648	18794	15266	12400	10072	8341	7897	7651			
	01 B 515	96210	1450	24943	18651	20260	16456	13367	10857						
	02 B 515	162800	1320	42207	28786	34283	27846	22618	18372						
	03 B 515	223500	1220	57944	41948	47065	38228	31051	25221						
6	100 B 600	89250	2060	23139	15648	18794	15266	12400	10072	8341	7897	7651			
	01 B 600	96210	1450	24943	18651	20260	16456	13367	10857						
	02 B 600	162800	1320	42207	28786	34283	27846	22618	18372						
	03 B 600	223500	1220	57944	41948	47065	38228	31051	25221						
6 7/16	01E B 607	133500	1320	34611	28113	22834	18547	15065	13340						
	02E B 607	199300	1200	51670	41969	34089	27689	22490	19915						
	03 B 607	259900	1110	67380	54730	44454	36108	29329							
6 1/2	01E B 608	133500	1320	34611	28113	22834	18547	15065	13340						
	02E B 608	199300	1200	51670	41969	34089	27689	22490	19915						
	03 B 608	259900	1110	67380	54730	44454	36108	29329							
6 15/16	01E B 615	125100	1320	32433	26344	21398	17380	14117	12500						
	02E B 615	210400	1200	54547	44306	35988	29231	23743							
	03 B 615	279200	1100	72384	58794	47756	38790	31507							
7	01E B 700	125100	1320	32433	26344	21398	17380	14117	12500						
	02E B 700	210400	1200	54547	44306	35988	29231	23743							
	03 B 700	279200	1110	72384	58794	47756	38790	31507							

Radial Load Carrying Capacity

Shaft Diameter d (in)	Reference	Bearing Ratings		Speed (rpm)											
		Cr (lb)	Max Speed (rpm)	50	100	200	400	800	1200	1500	1800	2000	2500	3000	3600
7 15/16	01E B 715	152600	1320	39562	32135	26101	21201	17221							
	02E B 715	255500	1200	66240	53803	43702	35497	28832							
	03 B 715	326200	1110	84569	68691	55795	45319	36811							
8	01E B 800	152600	1320	39562	32135	26101	21201	17221							
	02E B 800	255500	1200	66240	53803	43702	35497	28832							
	03 B 800	326200	1110	84569	68691	55795	45319	36811							
9	01E B 900	160600	1320	41636	33819	27470	22312	18123							
	02E B 900	277300	1200	71891	58394	47431	38526	31293							
	03 B 900	356500	1110	92424	75072	60977	49529								
10	01E B 1000	180700	1320	46847	38052	30908	25105	20392							
	02E B 1000	302600	1200	78451	63722	51758	42041								
	03 B 1000	399700	1110	103624	84169	68367	55531								
11	01E B 1100	206100	1320	53432	43401	35252	28634								
	02E B 1100	347300	1200	90039	73135	59404	48251								
	03X B 1100	439700	1110	113994	92592	75208	61088								
	03E B 1100	473200	1110	122679	99647	80938	65742								
12	01E B 1200	234000	1320	60666	49276	40024	32510								
	02E B 1200	373100	1200	96728	78568	63817	51835								
	03 B 1200	484700	1110	125661	102068	82905	67340								
13	01 B 1300	201000	590	52110	42327	34380	27925								
	02 B 1300	352900	550	91491	74314	60362	49029								
	03 B 1300	568500	500	147387	119715	97239	78982								
14	01 B 1400	210200	540	54495	44264	35954	29203								
	02 B 1400	392100	500	101654	82569	67067	54475								
	03E B 1400	618200	460	130271	130181	105740	85887								
15	01 B 1500	225900	500	58566	47570	38639	31385								
	02 B 1500	418600	460	108524	88149	71599	58157								
	03 B 1500	678700	420	175956	142921	116088	94293								
16	01 B 1600	235600	460	61080	49613	40298	32732								
	02 B 1600	437900	430	113528	92213	74900	60830								
17	01 B 1700	244800	430	63466	51550	41872	34010								
	02 B 1700	465100	400	120580	97941	79553	62617								
	03E B 1700	781000	360	202478	164463	133586									
18	01 B 1800	253800	410	65799	53445	43411	35261								
	02 B 1800	493400	380	127916	103900	84393									
	03E B 1800	820500	340	212719	172781	140342									

Shaft Diameter d (in)	Reference	Bearing Ratings		Speed (rpm)											
		Cr (lb)	Max Speed (rpm)	50	100	200	400	800	1200	1500	1800	2000	2500	3000	3600
19	01 B 1900	262800	380	68132	55341	44951									
	02 B 1900	520000	360	134813	109502	88943									
20	01 B 2000	272300	360	70595	57341	46575									
	02 B 2000	546300	340	141631	115040	93442									
	03 B 2000	918800	310	238204	193481	157156									
21	01 B 2100	281700	340	73032	59321	48183									
	02 B 2100	597500	330	154905	125822	102199									
22	01 B 2200	290900	330	75417	61258	49757									
	02 B 2200	627200	310	162605	132076	107279									
	03E B 2200	1050000	280	272218	221110	1795597									
23	01 B 2300	311800	310	80836	65659	53332									
	02 B 2300	525100	300	136135	110576	89815									
	03E B 2300	1099000	270	284921	231428	187978									
24	01 B 2400	321700	300	83402	67744	55025									
	02 B 2400	653000	290	169294	137509	111692									

SHAFT TOLERANCE

Journal diameter tolerance is generally h7.

For speeds over 5900dn(in) and all C2 clearance bearings the tolerance is h6.

For light loads and slow speeds wider tolerances up to h9 may be permissible. Please consult our technical department if a wider tolerance is required, or if it is required to mount a bearing on an existing shaft with a different tolerance to those specified above.

The tolerance on roundness and parallelism of the journal is IT6 in all cases.

Where the shaft is stepped so that the diameter of the shaft at the seals is different to the journal diameter, a wider tolerance (h9) is permissible for the shaft diameter at the seals.

The table below shows relevant tolerances for shaft diameters up to 24 inch.

TOLERANCES OF SHAFT DIAMETERS

Diameter (in.)	From Up to and including	-	2	3 3/16	4 3/4	7 1/8	9 7/8	12 7/16	15 3/4	19 11/16
	1 15/16	3 1/8	4 11/16	7 1/16	9 13/16	12 3/8	15 11/16	19 5/8	24 3/4	
Tolerance in 0.0001 in.										
Tolerance band (to BS 4500)	h6	+0	+0	+0	+0	+0	+0	+0	+0	+0
		-6	-7	-9	-10	-11	-13	-14	-16	-17
	h7	+0	+0	+0	+0	+0	+0	+0	+0	+0
		-10	-12	-14	-16	-18	-20	-22	-25	-28
	h9	+0	+0	+0	+0	+0	+0	+0	+0	+0
	-24	-29	-34	-39	-45	-51	-55	-61	-69	
IT6	6	7	9	10	11	13	14	16	17	

RECESS MOUNTING

For fixed (GR) bearings a shaft recess is required if the axial load exceeds the limits given on page 13 or if there is a combination of axial loading and one or more of the following: shock loads, vertical shafts, fluctuating temperatures over 212° F.

Recommended abutment diameters are given below.

Maximum fillet radius (r) may vary with bearing series. Refer to bearing data pages.

Bearing bore, d	Abutment diameter, D
Up to and including 3 1/2" / 90mm	d+3/16" / d+5mm
3 11/16" to 6" / 95mm to 155mm	d+3/8" / d+10mm
Over 6" / 155mm	d+3/8" / d+10mm

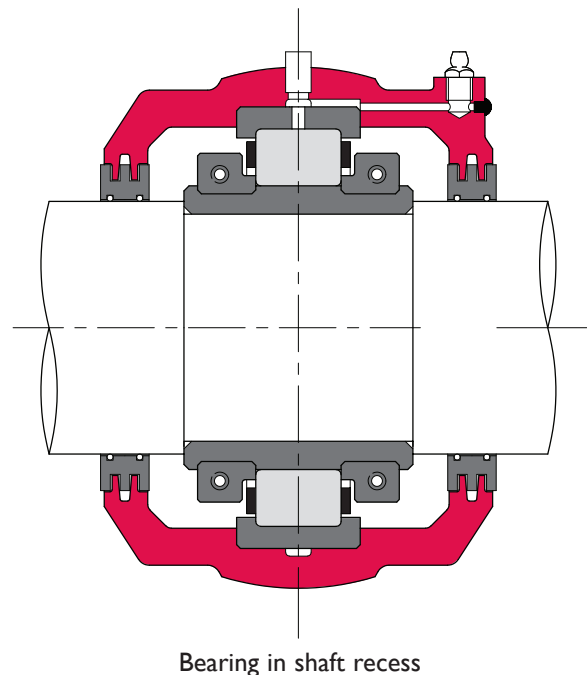

The tolerance on the width of the recess is D11, as per the table below.

If larger shaft fillet radii are required we can supply bearings with extra large chamfers to the inner race bores.

Note that recess mounting requires a special cartridge and seals to accommodate the larger shaft diameters. On some sizes a modified inner race is also required to allow the races

halves to be assembled onto the shaft in a truly radial direction. (With standard races it is sometimes necessary to incline the race half slightly to the shaft axis in order to get it into position, but this is prevented by the walls of the recess.) If the bearing is to be mounted in a shaft recess please inform our technical department so that they can advise on the required modifications and part codes.

TOLERANCES OF RECESS WIDTHS

Width (in.)	Over Up to and including	1.969	3.150	4.724	7.087	9.843	12.402	15.748
Tolerance in 0.0001 in.								
Tolerance D11 to BS 4500		+94	+114	+134	+156	+181	+201	+224
		+31	+39	+47	+57	+67	+75	+83

RETAINING RINGS

An alternative to recess mounting is to locate the inner race with retaining rings. Select retaining rings to accommodate the full axial load according to the manufacturer's data, and machine the grooves for the retaining rings as per the manufacturer's instructions.

The rings must be spaced so as to provide a journal width of D11 tolerance.

Note that the bore of the inner race has a chamfer. The retaining rings must be of sufficient diameter to abut effectively onto the parallel end faces of the inner race. The rings must not be excessively wide so as to interfere with the seals. In general it is permissible to locate the inner race of a GR bearing using retaining rings of a width up to half the total available axial movement of the equivalent EX bearing as specified in this catalog.

With this arrangement standard cartridges and seals may be used.

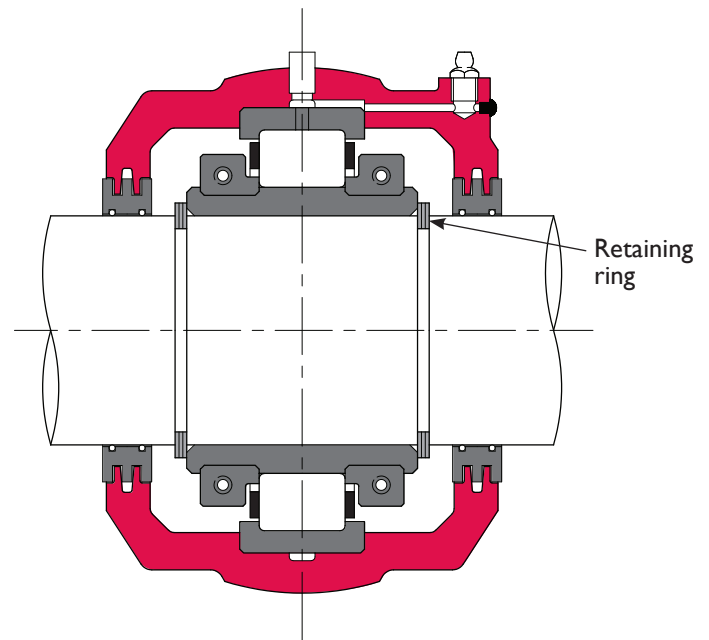

Bearing located by retaining rings

Bearing frequency data are included in this catalog for two purposes:

- to allow machine designers to check excitation frequencies against resonant frequencies in the machine,
- to allow correct input into condition monitoring equipment that uses this data.

BEARING GEOMETRY AND FREQUENCIES OF BEARING PARTS

A roller bearing will excite vibrations at certain frequencies related to the number, size and pitch circle diameter of the rollers. To some extent this excitation is present even with new bearings in perfect condition, as the load is carried on discrete, elastic, rolling elements which are constantly changing in angular position.

The tables opposite and on the following pages indicate the frequencies of bearing parts per shaft revolution, which can be used to calculate excitation frequencies directly by multiplying the tabulated frequencies by the shaft speed.

The frequencies listed are explained as follows:

‘Cage’ – the frequency at which a point on the cage enters and leaves the loaded zone of the bearing.

‘Roller’ – the frequency at which a point on a given roller passes into contact with either the inner or outer race.

‘Outer’ – the frequency at which a point on the outer race comes into contact with successive rollers.

‘Inner’ – the frequency at which a point on the inner race comes into contact with successive rollers.

The tables also list the pitch circle diameters and number of rollers, for use with condition monitoring equipment that accepts this information.

Note that the contact angle is 0 in all cases.

VIBRATION LEVELS

Velocity readings for a properly installed new bearing may be as high as 0.15ips.

Typically, alarm levels should be set no higher than 0.6ips.

Shutdown level should be set no higher than 0.8ips.

Shaft Dia. d	Bearing Reference	Part Frequencies (per shaft rev.)				Roller Details		
		Cage	Roller	Outer	Inner	PCD (in)	No.	Dia. (in)
1 3/16	01 B 103	0.405	2.538	4.051	5.949	2.469	10	0.469
1 1/4	1 B 104	0.405	2.538	4.051	5.949	2.469	10	0.469
1 7/16	1 B 107	0.405	2.538	4.051	5.949	2.469	10	0.469
1 1/2	1 B 108	0.405	2.538	4.051	5.949	2.469	10	0.469
1 11/16	01E B 111	0.415	2.857	4.980	7.020	3.012	12	0.512
1 3/4	01E B 112	0.415	2.857	4.980	7.020	3.012	12	0.512
1 15/16	01E B 115	0.415	2.857	4.980	7.020	3.012	12	0.512
	02 B 115	0.402	2.452	4.020	5.980	3.188	10	0.625
2	01E B 200	0.415	2.857	4.980	7.020	3.012	12	0.512
	02 B 200	0.402	2.452	4.020	5.980	3.188	10	0.625
2 3/16	01E B 203	0.417	2.934	5.840	8.160	3.563	14	0.591
	02 B 203	0.411	2.730	4.936	7.064	3.875	12	0.687
2 1/4	01E B 204	0.417	2.934	5.840	8.160	3.563	14	0.591
	02 B 204	0.411	2.730	4.936	7.064	3.875	12	0.687
2 7/16	01E B 207	0.417	2.934	5.840	8.160	3.563	14	0.591
	02 B 207	0.411	2.730	4.936	7.064	3.875	12	0.687
2 1/2	01E B 208	0.417	2.934	5.840	8.160	3.563	14	0.591
	02 B 208	0.411	2.730	4.936	7.064	3.875	12	0.687
2 11/16	01E B 211	0.420	3.053	5.883	8.117	4.193	14	0.669
	02 B 211	0.411	2.719	4.932	7.068	4.563	12	0.812
2 3/4	01E B 212	0.420	3.053	5.883	8.117	4.193	14	0.669
	02 B 212	0.411	2.719	4.932	7.068	4.563	12	0.812
2 15/16	100 B 215	0.448	4.723	8.953	11.047	3.760	20	0.394
	01E B 215	0.420	3.053	5.883	8.117	4.193	14	0.669
	02 B 215	0.411	2.719	4.932	7.068	4.563	12	0.812
3	100 B 300	0.448	4.723	8.953	11.047	3.760	20	0.394
	01E B 300	0.420	3.053	5.883	8.117	4.193	14	0.669
	2 B 300	0.411	2.719	4.932	7.068	4.563	12	0.812
3 3/16	01E B 303	0.423	3.187	6.774	9.226	4.882	16	0.748
	02 B 303	0.417	2.917	5.833	8.167	5.250	14	0.875

Shaft Dia. d	Bearing Reference	Part Frequencies (per shaft rev.)				Roller Details		
		Cage	Roller	Outer	Inner	PCD (in)	No.	Dia. (in)
3 1/4	01E B 304	0.423	3.187	6.774	9.226	4.882	16	0.748
	02 B 304	0.417	2.917	5.833	8.167	5.250	14	0.875
	100 B 307	0.446	4.592	8.924	11.076	4.390	20	0.472
3 7/16	01E B 307	0.423	3.187	6.774	9.226	4.882	16	0.748
	2 B 307	0.417	2.917	5.833	8.167	5.250	14	0.875
	01E B 308	0.423	3.187	6.774	9.226	4.882	16	0.748
3 1/2	02 B 308	0.417	2.917	5.833	8.167	5.250	14	0.875
	01E B 311	0.422	3.188	6.756	9.244	5.571	16	0.866
3 11/16	02 B 311	0.417	2.917	5.833	8.167	6.000	14	1.000
	01E B 312	0.422	3.188	6.756	9.244	5.571	16	0.866
3 3/4	02 B 312	0.417	2.917	5.833	8.167	6.000	14	1.000
	100 B 315	0.446	4.553	8.915	11.085	5.079	20	0.551
	01E B 315	0.422	3.188	6.756	9.244	5.571	16	0.866
3 15/16	02 B 315	0.417	2.917	5.833	8.167	6.000	14	1.000
	03 B 315	0.384	2.038	3.839	6.161	7.000	10	1.625
	100 B 400	0.446	4.553	8.915	11.085	5.079	20	0.551
	01E B 400	0.422	3.138	6.756	9.244	5.571	16	0.866
4	02 B 400	0.417	2.917	5.833	8.167	6.000	14	1.000
	03 B 400	0.384	2.038	3.839	6.161	7.000	10	1.625
	100 B 407	0.442	4.251	8.840	11.160	5.768	20	0.669
	01 B 407	0.430	3.501	6.880	9.120	6.250	16	0.875
4 3/16	02 B 407	0.417	2.917	5.833	8.167	6.750	14	1.125
	03 B 407	0.392	2.199	3.917	6.083	7.500	10	1.625
	100 B 408	0.442	4.251	8.840	11.160	5.768	20	0.669
	01 B 408	0.430	3.501	6.880	9.120	6.250	16	0.875
4 7/16	02 B 408	0.417	2.917	5.833	8.167	6.750	14	1.125
	03 B 408	0.392	2.199	3.917	6.083	7.500	10	1.625
	100 B 415	0.447	4.627	8.932	11.068	6.435	20	0.687
	01 B 415	0.432	3.599	6.909	9.091	6.875	16	0.937
4 15/16	02 B 415	0.417	2.917	5.833	8.167	7.500	14	1.250
	03 B 415	0.398	2.199	4.781	7.219	8.000	12	1.625

Shaft Dia. d	Bearing Reference	Part Frequencies (per shaft rev.)				Roller Details		
		Cage	Roller	Outer	Inner	PCD (in)	No.	Dia. (in)
5	100 B 500	0.447	4.627	8.932	11.068	6.435	20	0.687
	01 B 500	0.432	3.599	6.909	9.091	6.875	16	0.937
	02 B 500	0.417	2.917	5.833	8.167	7.500	14	1.250
	03 B 500	0.398	2.360	4.781	7.219	8.000	12	1.625
5 3/16	01 B 503	0.433	3.683	6.933	9.067	7.500	16	1.000
	02 B 503	0.419	3.014	5.869	8.131	8.125	14	1.313
5 7/16	100 B 507	0.447	4.654	8.938	11.062	7.060	20	0.750
	01 B 507	0.433	3.683	6.933	9.067	7.500	16	1.000
	02 B 507	0.419	3.014	5.869	8.131	8.125	14	1.313
	03 B 507	0.393	2.226	4.714	7.286	8.750	12	1.875
5 1/2	100 B 508	0.447	4.654	8.938	11.062	7.060	20	0.750
	01 B 508	0.433	3.683	6.933	9.067	7.500	16	1.000
	02 B 508	0.419	3.014	5.869	8.131	8.125	14	1.313
	03 B 508	0.393	2.226	4.714	7.286	8.750	12	1.875
5 15/16	100 B 515	0.443	4.300	8.852	11.148	7.625	20	0.875
	01 B 515	0.438	3.938	7.875	10.125	8.000	18	1.000
	02 B 515	0.421	3.103	6.743	9.257	8.750	16	1.375
	03 B 515	0.395	2.270	4.737	7.263	9.500	12	2.000
6	100 B 600	0.443	4.300	8.852	11.148	7.625	20	0.875
	01 B 600	0.438	3.938	7.875	10.125	8.000	18	1.000
	02 B 600	0.421	3.103	6.743	9.257	8.750	16	1.375
	03 B 600	0.395	2.270	4.737	7.263	9.500	12	2.000
6 7/16	01E B 607	0.432	3.632	7.784	10.216	8.740	18	1.181
	02E B 607	0.421	3.092	6.739	9.261	9.488	16	1.496
	03 B 607	0.409	2.642	5.720	8.280	10.250	14	1.875
6 1/2	01E B 608	0.432	3.632	7.784	10.216	8.740	18	1.181
	02E B 608	0.421	3.092	6.739	9.261	9.488	16	1.496
	03 B 608	0.409	2.642	5.720	8.280	10.250	14	1.875
6 15/16	01E B 615	0.440	4.092	8.796	11.204	9.154	20	1.102
	02E B 615	0.423	3.173	6.769	9.231	10.236	16	1.575
	03 B 615	0.411	2.717	5.753	8.247	10.875	14	1.937
7	01E B 700	0.440	4.092	8.796	11.204	9.154	20	1.102
	02E B 700	0.423	3.173	6.769	9.231	10.236	16	1.575
	03 B 700	0.411	2.717	5.753	8.247	10.875	14	1.937
7 15/16	01E B 715	0.442	4.246	9.722	12.278	10.167	22	1.181
	02E B 715	0.421	3.082	6.735	9.265	11.201	16	1.772
	03 B 715	0.413	2.796	5.786	8.214	12.250	14	2.125

Vibration Data

Shaft Dia. d	Bearing Reference	Part Frequencies (per shaft rev.)				Roller Details		
		Cage	Roller	Outer	Inner	PCD (in)	No.	Dia. (in)
8	01E B 800	0.442	4.246	9.722	12.278	10.167	22	1.181
	02E B 800	0.421	3.062	6.735	9.265	11.201	16	1.772
	03 B 800	0.413	2.796	5.786	8.214	12.250	14	2.125
9	01E B 900	0.448	4.727	10.745	13.255	11.289	24	1.181
	02E B 900	0.428	3.423	7.712	10.288	12.382	18	1.772
	03 B 900	0.414	2.808	4.964	7.036	13.750	12	2.375
10	01E B 1000	0.450	4.911	11.690	14.310	12.500	22	1.260
	02E B 1000	0.427	3.367	6.837	9.163	13.543	16	1.969
	03 B 1000	0.418	2.971	5.853	8.147	14.500	14	2.375
11	01E B 1100	0.449	4.856	11.675	14.325	13.524	26	1.378
	02E B 1100	0.433	3.668	7.795	10.205	14.705	18	1.969
	03X B 1100	0.425	3.240	6.794	9.206	15.750	16	2.375
	03E B 1100	0.423	3.160	6.764	9.236	15.375	16	2.375
12	01E B 1200	0.453	5.246	12.677	15.323	14.587	28	1.378
	02E B 1200	0.438	3.953	8.755	11.245	15.807	20	1.969
	03 B 1200	0.426	3.326	6.824	9.176	17.000	16	2.500
13	01 B 1300	0.458	5.910	11.908	14.092	15.625	26	1.312
	02 B 1300	0.443	4.297	8.852	11.148	16.875	20	1.937
	03 B 1300	0.423	3.184	5.927	8.073	18.748	14	2.875
14	01 B 340M	0.461	6.294	12.895	15.105	16.625	28	1.312
	02 B 340M	0.443	4.337	8.862	11.138	18.125	20	2.063
	03E B 340M	0.428	3.405	6.850	9.150	19.125	16	2.750
15	01 B 1500	0.461	6.416	12.915	15.085	17.750	28	1.375
	02 B 1500	0.446	4.552	9.806	12.194	19.000	22	2.063
	03 B 1500	0.429	3.429	6.857	9.143	21.000	16	3.000
16	01 B 1600	0.463	6.782	13.900	16.100	18.750	30	1.375
	02 B 1600	0.447	4.682	9.839	12.161	20.125	22	2.125
	03 B 1600	0.429	3.429	6.857	9.143	21.000	16	3.000

Shaft Dia. d	Bearing Reference	Part Frequencies (per shaft rev.)				Roller Details		
		Cage	Roller	Outer	Inner	PCD (in)	No.	Dia. (in)
17	01 B 1700	0.465	7.147	14.886	17.114	19.750	32	1.375
	02 B 1700	0.449	4.806	9.868	12.132	21.250	22	2.188
	03E B 1700	0.435	3.759	8.693	11.307	22.283	20	2.913
18	01 B 1800	0.467	7.512	15.873	18.127	20.750	34	1.375
	02 B 1800	0.451	5.008	10.814	13.186	22.125	24	2.188
	03E B 1800	0.433	3.683	7.800	10.200	23.622	18	3.150
	03X B 1800	0.432	3.598	6.909	9.091	24.750	16	3.375
19	01 B 1900	0.467	7.576	14.949	17.051	21.875	32	1.437
	02 B 1900	0.453	5.267	11.777	14.223	23.250	26	2.188
20	01 B 2000	0.469	7.925	15.932	18.068	22.875	34	1.437
	02 B 2000	0.455	5.469	12.731	15.269	24.125	28	2.188
	03 B 2000	0.437	3.900	7.864	10.136	26.750	18	3.375
21	01 B 2100	0.470	8.362	16.927	19.073	24.125	36	1.437
	02 B 2100	0.453	5.322	11.789	14.211	25.500	26	2.375
22	01 B 2200	0.471	8.711	17.913	20.087	25.125	38	1.437
	02 B 2200	0.455	5.561	12.751	15.249	26.625	28	2.375
	03E B 2200	0.440	4.107	8.800	11.200	28.125	20	3.375
23	01 B 2300	0.471	8.721	17.914	20.086	26.250	38	1.500
	02 B 2300	0.461	6.432	13.841	16.159	27.500	30	2.125
	03E B 2300	0.442	4.244	9.722	12.278	29.134	22	3.386
24	01 B 2400	0.472	9.056	18.899	21.101	27.250	40	1.500
	02 B 2400	0.458	5.958	13.750	16.250	28.500	30	2.375

Efficient performance and long life of the roller bearing depend to a large extent upon the exclusion of foreign matter from the internal bearing surfaces. Grease, or oil, serves the dual purpose of lubricating these surfaces and protecting them from corrosion. Thus the seal must prevent dust, grit and moisture from entering the bearing and at the same time prevent grease or oil from escaping.

ALIGNMENT FEATURE

Cooper supplies various mounting options and for all, except the hanger mountings, the bearing is housed in a cartridge supported by the mounting unit. Cartridges have a spherical outer surface that fits into a conforming surface in the mounting unit (such as pillow block or flange) in the manner of a ball and socket joint.

Any shaft misalignment that may exist tends to move the cartridge, seal and bearing together, maintaining the seal on an axis parallel to the shaft. Standard pillow blocks and flanges are designed to allow up to 2 1/2° misalignment between the shaft and housing, under constant or slowly changing alignment conditions, without compromising sealing.

Compare this with the situation that occurs with a double row spherical bearing in a standard pillow block. If the pillow block is not accurately aligned with the shaft, contact between the seal and the shaft tends to be lost at one side, and the seal presses more heavily against the shaft at the other. In the worst case a gap may open, compromising the sealing, or the seal may bind on the shaft. Although felt seals are shown in the illustration, a similar situation occurs with labyrinth or lip seals.

SEAL TYPES

Cartridges for shaft sizes up to 12"/300mm are usually supplied with a general purpose felt seal. The felt groove will also accommodate high temperature packing seals, lipped seals or suitable blanking plates.

Triple labyrinth seals are often supplied as an alternative and are precision non-rubbing seals capable of high speed operation. Due to the aligning feature described above, extremely close tolerances can be maintained between the housing and the shaft. The result is an effective sealing element which is one of the best in the anti-friction bearing industry.

Cartridges for shaft sizes over 12"/300mm are supplied with grease groove seals as standard.

Cooper offer a wide range of sealing options, the more common of which are illustrated overleaf. For special applications seals may be made from other materials and alternative special seals can be supplied to suit specific conditions.

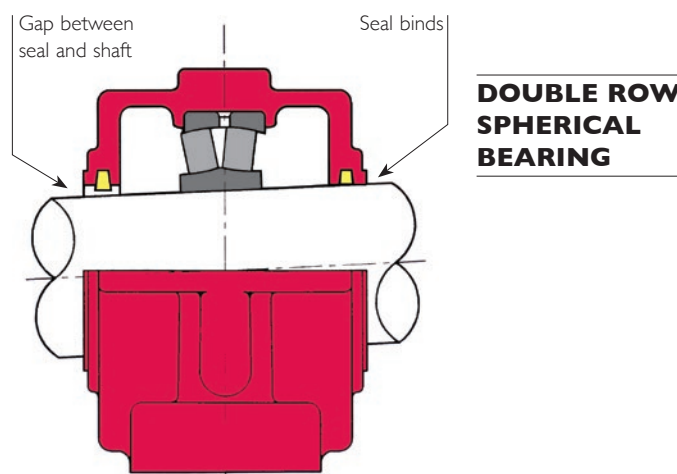
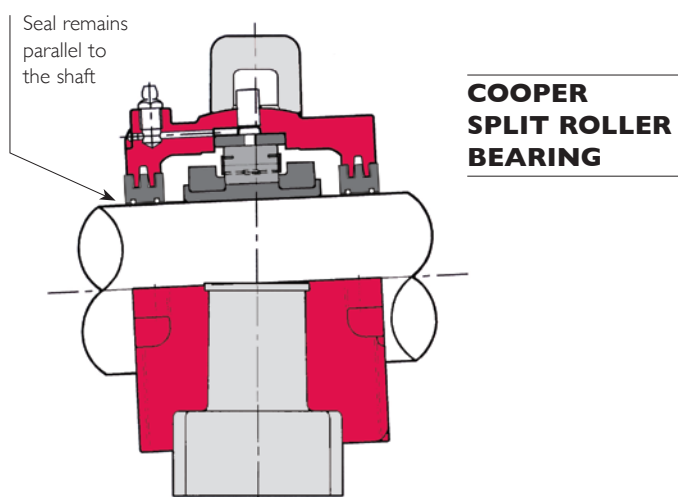
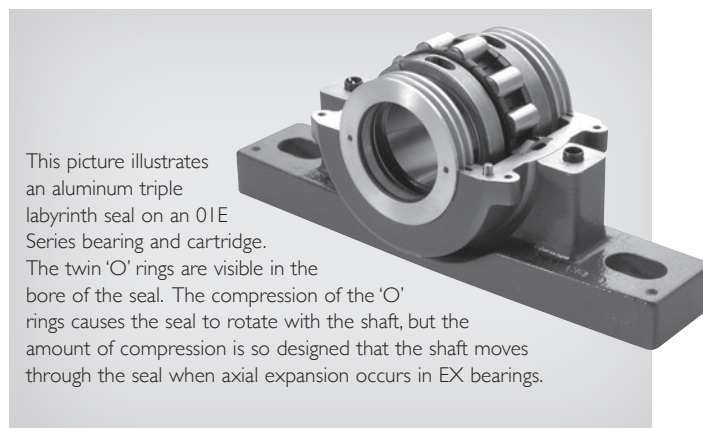

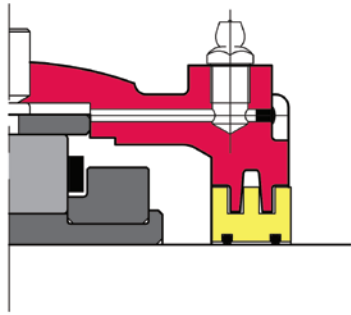

ALUMINUM TRIPLE LABYRINTH (ATL)

HIGH TEMPERATURE VERSION (ATL HT)
LOW TEMPERATURE VERSION (ATL LT)

Machined aluminum bodied triple labyrinth seal for high speed and general applications. ATL supplied as standard sealing arrangement in USA and Canada. ATL HT and ATL LT are fitted with O rings of different materials.

Temperature limits ATL -4° F to 212° F
ATL HT -4° F to 347° F
ATL LT -76° F to 212° F

Maximum speed Bearing maximum

Shaft surface finish 125µinCLA (max. roughness)

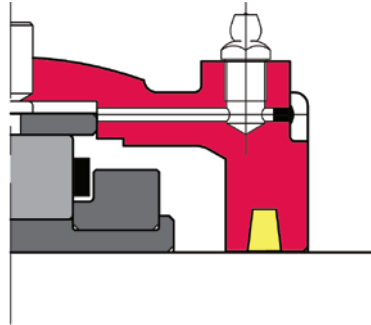

FELT (F)

Standard in UK and Europe

Temperature limits -94° F to 212° F

Maximum speed 5,900 dn(in)

Shaft surface finish 63µinCLA (max. roughness)

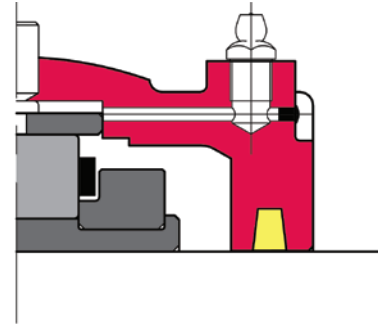

HIGH TEMPERATURE PACKING (HTP)

A direct replacement for felt in high temperature applications.

Temperature limits -94° F to 500° F

Maximum speed 5,900 dn(in)

Shaft surface finish 32µinCLA (max. roughness)

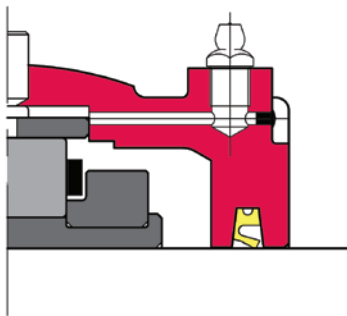

SYNTHETIC RUBBER SINGLE LIP (SRS)

HIGH TEMPERATURE VERSION (SRS HT)

LOW TEMPERATURE VERSION (SRS LT)

Suitable for wet but not submerged conditions. Can be used for improved lubricant retention by mounting lip inwards.

Temperature limits SRS -4° F to 212° F

SRS HT -4° F to 347° F

SRS LT -76° F to 212° F

Maximum speed 5,900 dn(in)

Shaft surface finish 32µinCLA (max. roughness)

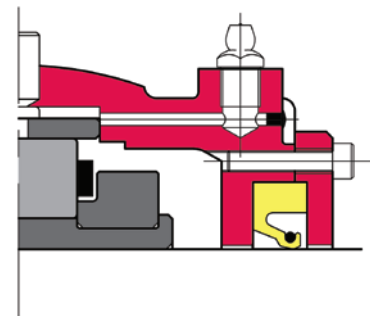

SPRING-LOADED SINGLE LIP WITH RETAINING PLATE (SRSRP)

HIGH PRESSURE VERSION (SRSRP 40M)

Suitable for severe splash or completely submerged conditions. The standard version is suitable for up to 2m of water. The high pressure version is suitable for up to 40m of water.

Temperature limits -4° F to 100° F

Maximum speed 5,900 dn(in)

Shaft surface finish 16µinCLA

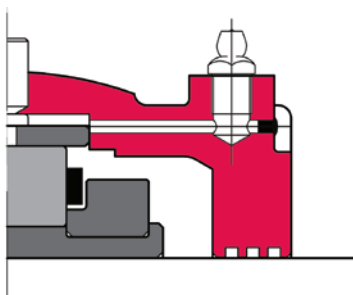

GREASE GROOVE (LAB)

Suitable for high or slow speed operations. Particularly successful on marine applications.

Temperature limits Bearing maximum

Maximum speed Bearing maximum

Shaft surface finish 125µinCLA

SEAL SELECTION

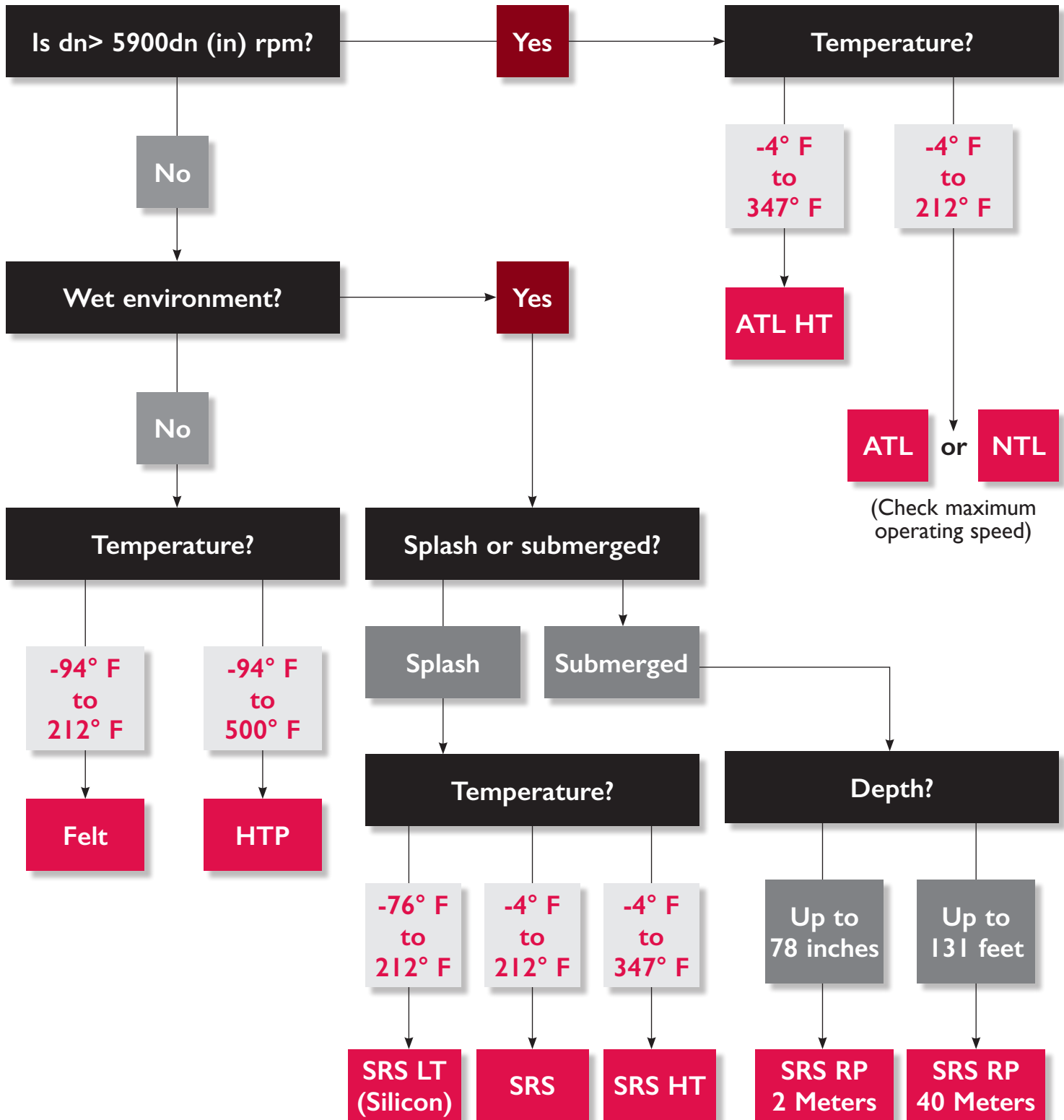

BLANKING PLATES

Where shafts terminate at the bearings, 'blanking plates' may be used to close off the cartridge ends.

Blanking plates are available to suit standard single groove and TL cartridges.

On sizes up to 3 1/2"/90mm blanking plates accommodating thrust bearings can be used for axial location of shafts. A typical application is on the shafts of belt conveyors.

For blanking plates with thrust bearings, the shaft ends must be machined smooth and square. Upon assembly, there must be slight clearance between the shaft ends and the thrust bearings (i.e. slight end float), without the possibility of preload.

Blanking plates with thrust bearings are limited to a maximum speed of 790 dn (in) (calculated using the shaft size, not the bore of the thrust bearing) and to shaft location only (i.e. only nominal axial loading).

DIMENSIONS

Dimensions for shaft terminations, when using blanking plates with thrust bearings, are shown below:

Shaft diameter d	01 Series		02 Series		
	K	t	K	t	
1 3/16"	1 1/16	5/64	-	-	
1 1/4"					
1 7/16"					
1 1/2"					
1 11/16"	1 9/64	3/64	-	-	
1 3/4"					
1 15/16"	1 9/64	3/64	1 3/8	3/64	
2"					
	55mm	1 3/16	5/64	-	-
2 3/16"	60mm	1 3/16	5/64	1 1/2	5/64
2 1/4"					
2 7/16"					
2 1/2"					
2 11/16"	70mm	1 3/8	5/32	1 5/8	0
2 3/4"					
2 15/16"					
3"	75mm				
3 3/16"	80mm				
3 1/4"	85mm	1 37/64	5/32	1 7/8	1/8
3 7/16"	90mm				
3 1/2"					

BP

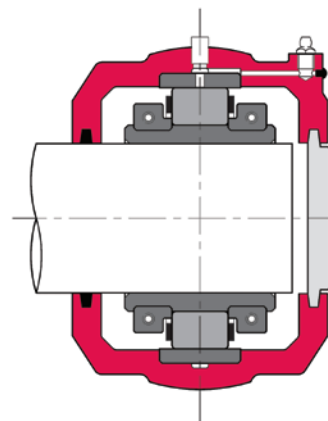

BPTL

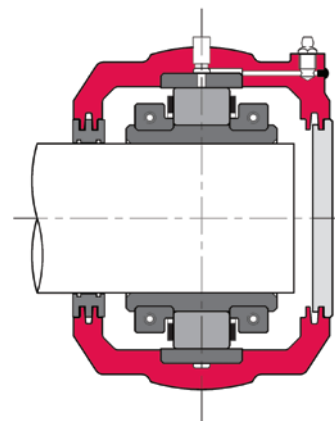

BT

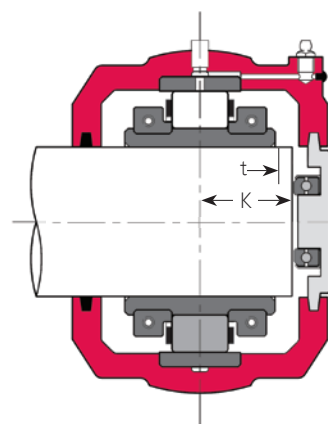

BTTL

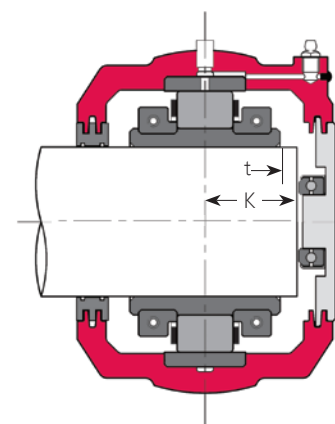

ORDERING

For blanking plates to suit TL cartridges, the part code is made up as follows:



Series of bearing and cartridge to which blanking plate is to be fitted (i.e. 100, 01, 02, or 03)

BPTL for blanking plate with thrust bearing

BTTL for blanking plate with thrust bearing

Size reference: _____

Use the last two digits of the cartridge reference, e.g. if the cartridge reference is 01 C 02, the digits to be put here are 02 as shown

For blanking plates to suit single groove cartridges, the part code is made up as follows:



Series of bearing and cartridge to which blanking plate is to be fitted (i.e. 100, 01, 02, or 03)

BP for blanking plate with thrust bearing

BT for blanking plate with thrust bearing

Size reference: _____

For inch sizes the first digit(s) indicate whole number of inches and the last two digits indicate sixteenths of an inch, e.g.:

307 = 3-7/16"

1200 = 12"

For metric sizes this is the bore size in mm followed by 'M', e.g.:

90M = 90mm

BT and BTTL blanking plates are only regarded as standard items for 01 and 02 Series cartridges up to 3 1/2"/90mm bore size.

For all blanking plates, if the cartridge end bore is machined to suit a shaft diameter that is different to the bore of the bearing, refer to Cooper for the relevant part code.

BEARING LUBRICATION

Friction and wear are reduced by separating rollers and races with a lubricant film to minimize metal to metal contact. The major factors in selecting a lubricant are speed, lubricant base oil, viscosity and temperature.

As speed and viscosity increase, thickness of lubricant film increases. As temperature increases, lubricant film thickness decreases. The lubricant film should be sufficient to cover the average peaks on the bearing surface by a ratio of at least 1.25. As the ratio falls below 1.25, some metal to metal contact will occur with a corresponding loss of L_{10} life.

This situation should not occur if the lubricant is selected according to the method given on page 31.

GREASE LUBRICATION

Standard cartridges are designed for grease lubrication. Lubrication points are tapped 1/8" NPT or 1/4" NPT depending on size, and fitted with grease nipples. Alternative tappings or fittings are available on request.

Grease lubrication is easier to retain in the bearing than oil, offering lower lubricant losses and improved sealing. Grease also offers better protection against corrosion to the rolling surfaces.

A grease typically consists of three components; a thickener (sometimes called a soap), a base oil and additives. The oil in the grease has an ISO-VG rating. In most cases, this is the key to selecting the grease. At speeds in excess of 7900 dn (in), greases with synthetic base oils are recommended. Please consult our technical department for proper grease selection.

The National Lubricating Grease Institute (NLGI) has designated consistency grades for greases based upon the amount of thickener in the grease. The standard recommended grease for Cooper is a No.2 or No.3 consistency grade with an EP additive. The exception to this is a centrally pumped system where a No.1 is used for "pumpability".

dn (in) = bearing bore (in) x shaft speed (rpm)

A lithium complex thickener is used for normal applications operating at temperatures between 32° F and 176° F. When water resistance is required, an aluminum complex thickener can be used. Aluminum complex greases are not compatible with some other types of grease. The bearing must therefore be solvent cleaned of other greases prior to adding an aluminum complex based grease.

The initial pack of grease depends on speed. The initial pack should be used to coat the rolling surfaces of the bearing during installation. Further information is to be found on page 172.

For extreme temperatures, speeds and loads always obtain a lubricant selection from our technical department.

OIL LUBRICATION

Oil lubrication can be broken down into three major categories; recirculating oil systems, constant level and oil mist.

Recirculating oil systems use a pump to provide a continuous flow of oil to the bearing which is then recaptured, cooled, filtered and recirculated.

A constant level oiler is the simplest method for delivery of oil lubrication to a bearing. The oiler maintains a constant level in the bottom of the bearing. Ideal conditions for oiler use would be bearing temperature less than 140° F and downwards load with low to moderate speeds.

An oil mist system uses compressed air to atomise oil and spray it into the bearing. Conveying oil with filtered air maintains a positive pressure in the cartridge which is an effective method for keeping out contaminants. Oil mist systems are especially effective for high speeds.

If oil lubrication is required a modified cartridge is required. Please contact our technical department with details of lubrication system to be used.

SELECTION OF BASE OIL VISCOSITY (ISO-VG)

Grease selected for bearing lubrication must have a base oil of sufficiently high viscosity to adequately separate the rolling elements and race parts under operating conditions, in order for the bearing to provide a long service life. The same comment applies for the viscosity of the oil if oil lubrication is used.

The charts on page 33 show the recommended operating ranges for three common oil viscosities, for bearings under normal loading (for radial loads up to Cr/10).

In order to use these charts, the 'geometry factor' for the bearing in question must be found, from the table opposite and on the following pages, and this geometry factor multiplied by the bearing speed (in thousands of rpm) in order to obtain the 'velocity factor'.

For example, if an 01E B 207 bearing is to be run at 1800rpm:

The geometry factor is 48.2 from the table.
 Velocity factor = $48.2 \times 1800/1000 = 86.76$

To determine the suitability of one of these oils, draw a vertical line from the horizontal axis at the calculated velocity factor, and draw a horizontal line from vertical axis at the operating temperature.

If the lines intersect in the shaded area the viscosity of the oil is suitable.

If the lines intersect above the shaded area a higher viscosity oil is required.

If the lines intersect below the shaded area the bearing may operate satisfactorily, but it is suggested that a lower viscosity oil is used.

The use of these charts is subject to the operating conditions being within the recommended ranges for the lubricant as specified by the lubricant manufacturer.

For conditions not covered by these charts, please contact our technical department.

Note that the lubricant film thickness is not particularly sensitive to load, so for heavier loading the lubricant selection as provided by these charts is usually sufficient provided that the lines drawn on the chart, as explained above, do not intersect at the upper edge of the shaded area.

It is recommended that our technical department is contacted with details of the application if extremes of load, speed or temperature are expected.

Shaft Dia. d	Bearing Reference	Geometry Factor	Shaft Dia. d	Bearing Reference	Geometry Factor
1 3/16	01 B 103	27.3	3 3/16	01E B 303 02 B 303	77.2 83.7
1 1/4	1 B 104	27.3	3 1/4	01E B 304 02 B 304	77.2 83.7
1 7/16	1 B 107	27.3	3 7/16	100 B 307 01E B 307 2 B 307	71.5 77.2 83.7
1 1/2	1 B 108	27.3	3 1/2	01E B 308 02 B 308	77.2 83.7
1 11/16	01E B 111	37.6	3 11/16	01E B 311 02 B 311	92.8 101
1 3/4	01E B 112	37.6	3 3/4	01E B 312 02 B 312	92.8 101
1 15/16	01E B 115 02 B 115	37.6 39.0	3 15/16	100 B 315 01E B 315 02 B 315 03 B 315	87.9 92.8 101 112
2	01E B 200 02 B 200	37.6 39.0	4	100 B 400 01E B 400 02 B 400 03 B 400	87.9 92.8 101 112
2 3/16	01E B 203 02 B 203	48.2 53.2	4 3/16	01 B 403 02 B 403	112 120
2 1/4	01E B 204 02 B 204	48.2 53.2	4 7/16	100 B 407 01 B 407 02 B 407 03 B 407	104 112 120 127
2 7/16	01E B 207 02 B 207	48.2 53.2			
2 1/2	01E B 208 02 B 208	48.2 53.2			
2 11/16	01E B 211 02 B 211	61.4 67.1			
2 3/4	01E B 212 02 B 212	61.4 67.1			
2 15/16	100 B 215 01E B 215 02 B 215	57.5 61.4 67.1			
3	100 B 300 01E B 300 2 B 300	57.5 61.4 67.1			

Lubrication

Shaft Dia. d	Bearing Reference	Geometry Factor	Shaft Dia. d	Bearing Reference	Geometry Factor	Shaft Dia. d	Bearing Reference	Geometry Factor	Shaft Dia. d	Bearing Reference	Geometry Factor
4 1/2	100 B 408	104	6 7/16	01E B 607	183	11	01E B 1100	360	18	01 B 1800	701
	01 B 408	112		02E B 607	198		02E B 1100	385		02 B 1800	730
	02 B 408	120		03 B 607	212		03X B 1100	413		03E B 1800	759
	03 B 408	127					03E B 1100	397		03X B 1800	807
4 15/16	100 B 415	124	6 1/2	01E B 608	183	12	01E B 1200	406	19	01 B 1900	757
	01 B 415	129		02E B 608	198		02E B 1200	434		02 B 1900	790
	02 B 415	139		03 B 608	212		03 B 1200	463			
	03 B 415	143									
5	100 B 500	124	6 15/16	01E B 615	200	13	01 B 1300	455	20	01 B 2000	810
	01 B 500	129		02E B 615	222		02 B 1300	484		02 B 2000	837
	02 B 500	139		03 B 615	232		03 B 1300	527		03 B 2000	917
	03 B 500	143									
5 3/16	01 B 503	147	7	01E B 700	200	14	01 B 340M	501	21	01 B 2100	879
	02 B 503	158		02E B 700	222		02 B 340M	536		02 B 2100	903
				03 B 700	232		03E B 340M	551			
5 7/16	100 B 507	141	7 15/16	01E B 715	234	15	01 B 1500	551	22	01 B 2200	934
	01 B 507	147		02E B 715	251		02 B 1500	579		02 B 2200	966
	02 B 507	158		03 B 715	277		03 B 1500	631		03E B 2200	995
	03 B 507	160									
5 1/2	100 B 508	141	8	01E B 800	234	16	01 B 1600	600	23	01 B 2300	995
	01 B 508	147		02E B 800	251		02 B 1600	631		02 B 2300	1031
	02 B 508	158		03 B 800	277		03 B 1600	631		03E B 2300	1053
	03 B 508	160									
5 15/16	100 B 515	155	9	01E B 900	277	17	01 B 1700	650	24	01 B 2400	1053
	01 B 515	164		02E B 900	297		02 B 1700	685		02 B 2400	1075
	02 B 515	176		03 B 900	328		03E B 1700	701			
	03 B 515	181									
6	100 B 600	155	10	01E B 1000	322						
	01 B 600	164		02E B 1000	336						
	02 B 600	176		03 B 1000	359						
	03 B 600	181									

**COOPER BEARING
RECOMMENDED SPEED
AND TEMPERATURE
RANGE FOR ISO VG 150
GREASE AND OILS**

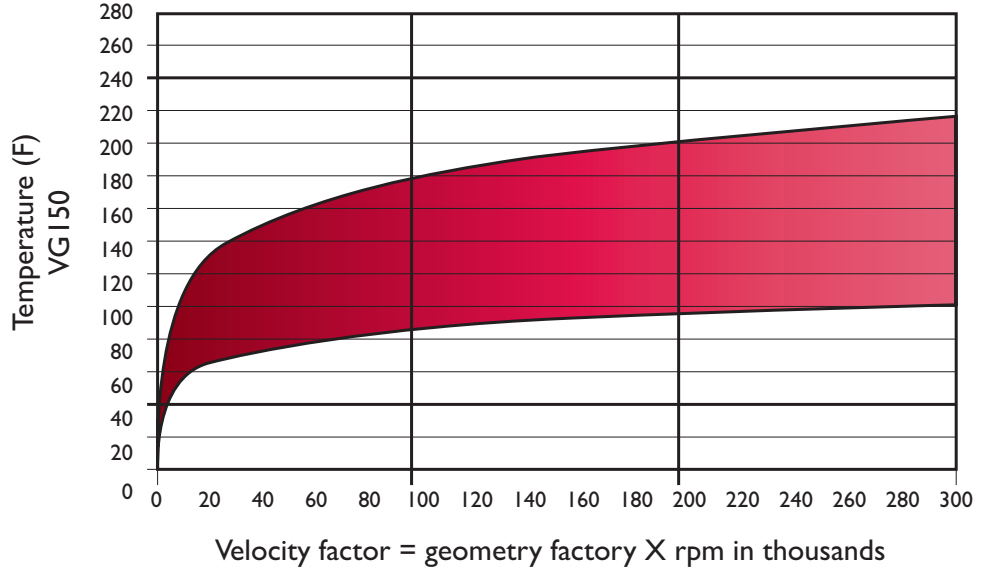

**COOPER BEARING
RECOMMENDED SPEED
AND TEMPERATURE
RANGE FOR ISO VG 220
GREASE AND OILS**

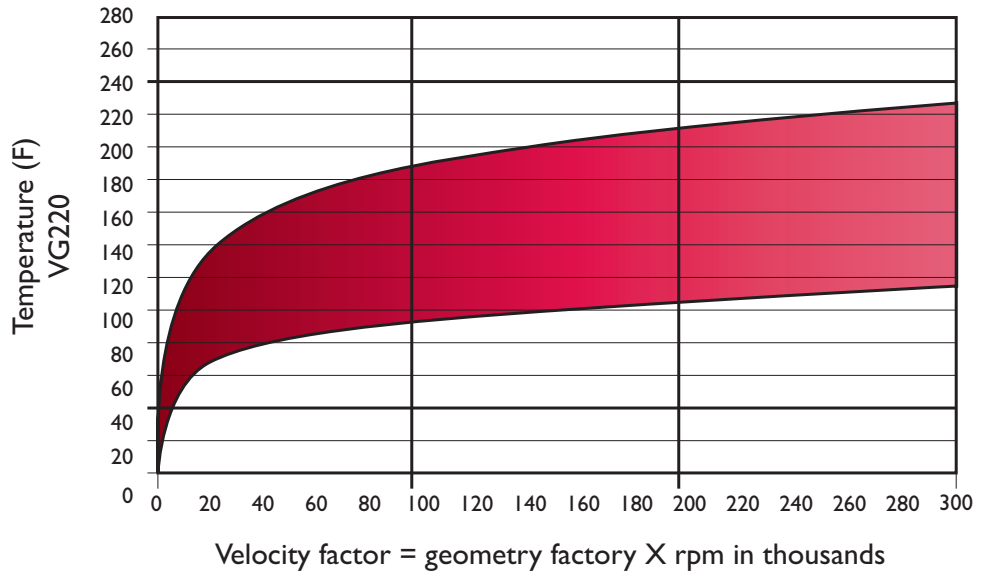

**COOPER BEARING
RECOMMENDED SPEED
AND TEMPERATURE
RANGE FOR ISO VG 460
GREASE AND OILS**

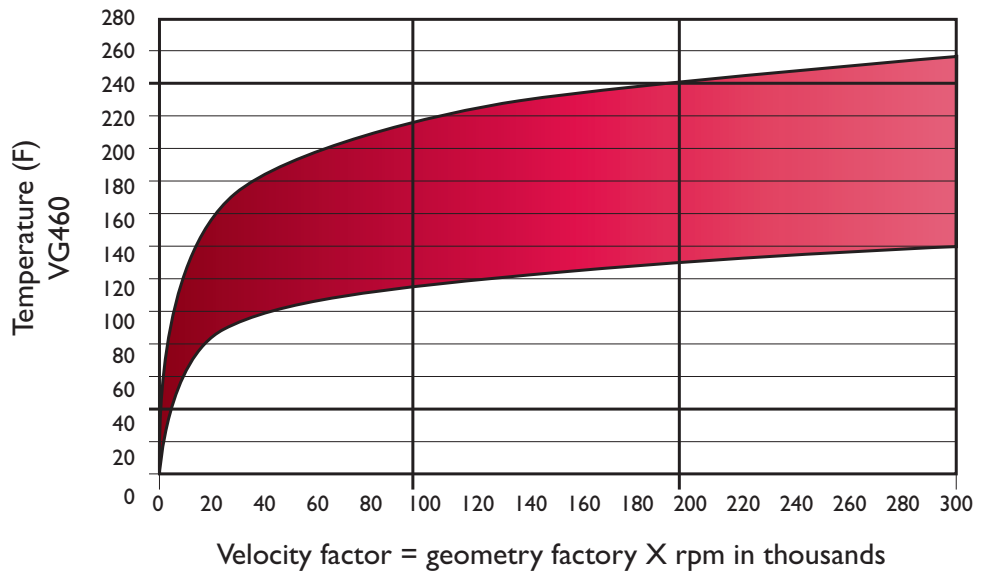

BEARINGS

The following pages list standard bearings of Series 100, 01, 02 and 03, alongside compatible standard cartridges and pillow blocks. Principles of bearing selection are explained on pages 11 to 13.

Large bore bearings and 04 Series bearings are listed separately elsewhere in this catalog.

CARTRIDGES AND SEALS

Most Cooper split roller bearings are mounted in a 'cartridge'. This is a spherically-machined inner housing that can be fitted into a number of outer housings including pedestals, flanges, rod-ends, take-up units and custom housings either supplied by Cooper or manufactured by the customer.

The cartridge houses the bearing and seals. For any given size of bearing there are two main types of cartridge. The standard cartridge in the US and Canada, is the 'triple labyrinth' (TL) type, which accommodates either an aluminum triple labyrinth (ATL) seal or, on some sizes only, a neoprene triple labyrinth (NTL).

Outside the US and Canada, but readily available in the US and Canada, the standard cartridge up to 12"/300mm shaft size features a groove in each end bore that can accommodate a felt seal (supplied as standard with the cartridge), high temperature packing, or a rubber lipped seal. The standard cartridge for shaft sizes over 12"/300mm outside the US and Canada features groove grease seals.

Cartridges to accommodate other types of seal, such as lip seals for submerged conditions, and combinations of seals, may require special machining and may have a different length on shaft to the standard types listed.

Cartridges for expansion (EX) and fixed (GR) bearings differ, so care must be taken to order the correct version and ensure that EX and GR bearings are fitted in the correct cartridges during assembly. Cartridges for GR bearings feature drillings for 'side screws' that locate the outer race against one side of the seating, while cartridges for EX bearings may include additional internal machining.

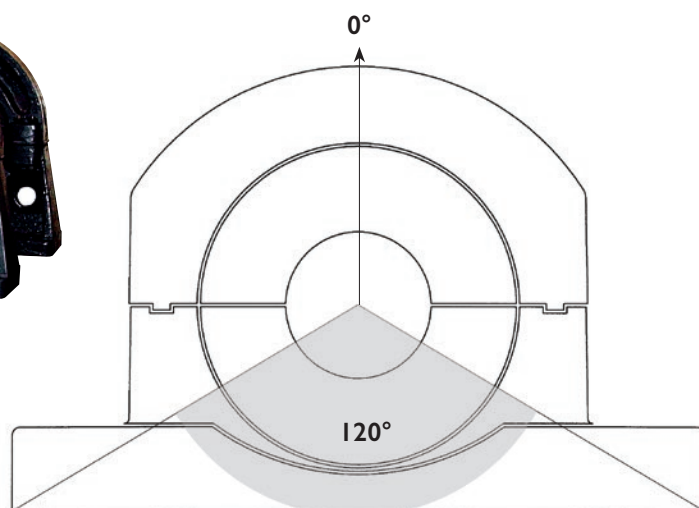
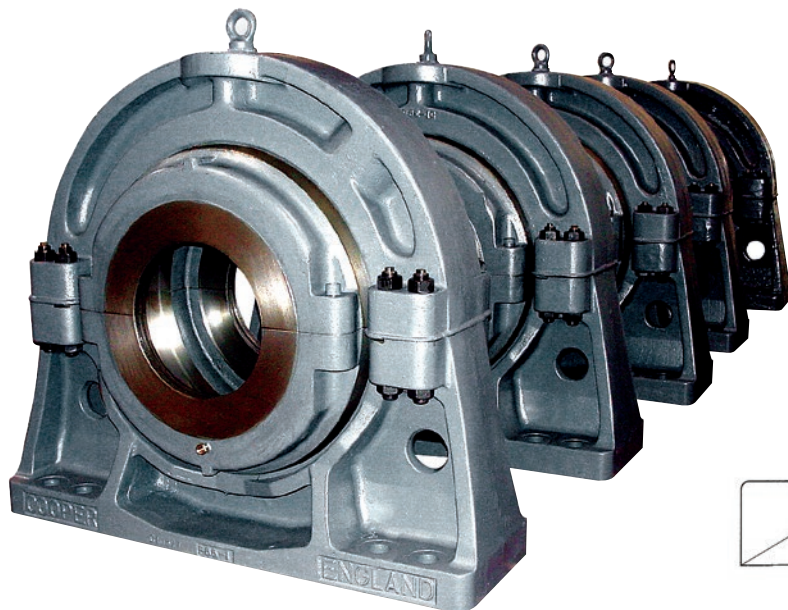

PILLOW BLOCKS

Pillow blocks (also known as Pedestals) are the most common method of mounting Cooper split roller bearings (in cartridges as explained on the previous page).

Cooper standard pillow blocks are shown on the following pages. Pillow blocks with height-to-center and bolt hole configurations to match industry standard SAF, SN and SD pillow blocks are listed separately in this catalog.

Pillow blocks with additional features to aid their application to marine drive systems are shown on page 75.

Pillow blocks are common between expansion (EX) and fixed (GR) units.

LOADS AND MOUNTING

The maximum safe radial load for a pillow block is based on the static rating (C_{or}) of the corresponding size of roller bearing. The full static rating can be applied if the angle of the load falls within the shaded area of the sketch.

If the radial load falls outside the shaded area, if the radial load exceeds C_{or} , or if the axial loads exceed 50% of the axial rating (C_a) of the corresponding roller bearing please consult our technical department. For 100 Series bearings, the maximum axial load is reduced to 35% and for 01E and 02E Series to 26% C_a due to their higher axial load ratings.

Pillow blocks should be fully supported on a flat, rigid surface to avoid distortion of the pillow block or deflection under load.

For loads within 45° of the horizontal, the base should be chocked or dowelled.

Standard Cooper pillow blocks are manufactured from gray iron. Ductile iron and steel pillow blocks are also available and should be considered for shock or pulsating loads. Particulars of pillow blocks in alternative materials are available from our technical department.

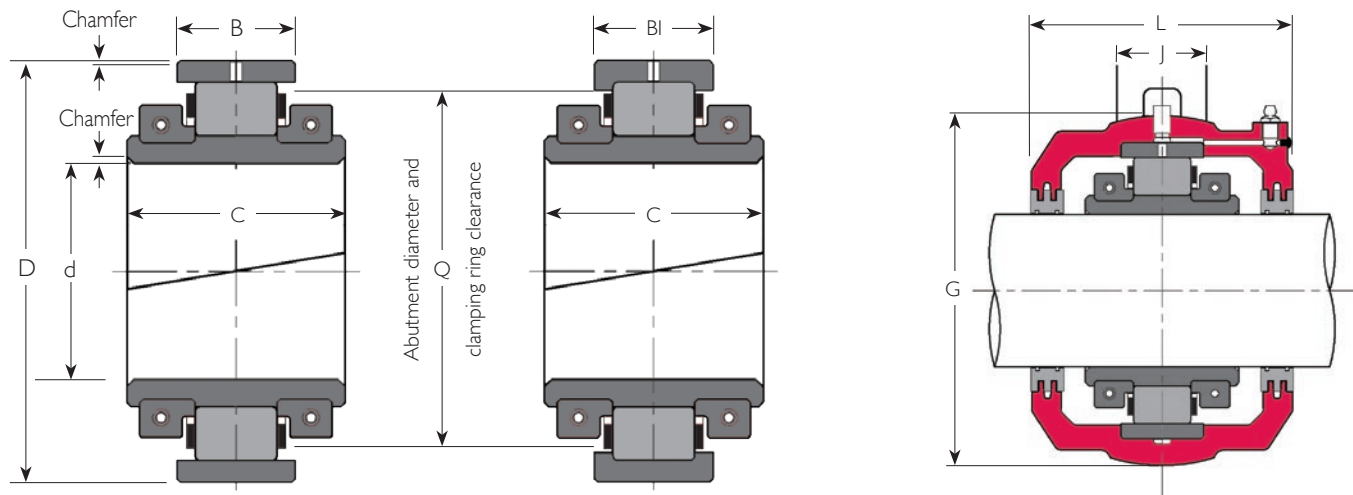

ROLLER BEARING

Shaft Dia. d (in)	Reference (1)	Bearing Ratings				Principal Dimensions					Axial Movement (2)		
		Cr (lb)	Cor (lb)	Ca (lb)	Max. Speed (rpm)	D (in)	C (in)	B (in)	BI (in)	Q (in)	Usual (in)	Max. (in)	Mass (lb)
1 3/16	01 B 103	15060	15060	719	5400	3.313	1.972	0.937	0.937	2.95	1/8	7/32	2.6
1 1/4	01 B 104	15060	15060	719	5400	3.313	1.972	0.937	0.937	2.95	1/8	7/32	2.6
1 7/16	01 B 107	15060	15060	719	5400	3.313	1.972	0.937	0.937	2.95	1/8	7/32	2.6
1 1/2	01 B 108	15060	15060	719	5400	3.313	1.972	0.937	0.937	2.95	1/8	7/32	2.6
1 11/16	01E B 111	21360	23600	854	4630	3.875	2.193	1.000	1.000	3.54	5/32	3/16	3.3
1 3/4	01E B 112	21360	23600	854	4630	3.875	2.193	1.000	1.000	3.54	5/32	3/16	3.3
1 15/16	01E B 115	21360	23600	854	4630	3.875	2.193	1.000	1.000	3.54	5/32	3/16	3.3
	02 B 115	26750	28100	1393	4350	4.250	2.657	1.378	1.378	3.86	3/16	7/16	4.4
2	01E B 200	21360	23600	854	4630	3.875	2.193	1.000	1.000	3.54	5/32	3/16	3.3
	02 B 200	26750	28100	1393	4350	4.250	2.657	1.378	1.378	3.86	3/16	7/16	4.4
2 3/16	01E B 203	30350	35290	1618	3940	4.500	2.193	1.063	1.063	4.13	3/16	3/16	4.0
	02 B 203	37770	43390	1978	3680	5.000	2.846	1.531	1.531	4.57	7/32	7/16	6.6
2 1/4	01E B 204	30350	35290	1618	3940	4.500	2.193	1.063	1.063	4.13	3/16	3/16	4.0
	02 B 204	37770	43390	1978	3680	5.000	2.846	1.531	1.531	4.57	7/32	7/16	6.6
2 7/16	01E B 207	30350	35290	1618	3940	4.500	2.193	1.063	1.063	4.13	3/16	3/16	4.0
	02 B 207	37770	43390	1978	3680	5.000	2.846	1.531	1.531	4.57	7/32	7/16	6.6

CARTRIDGE

References (1)		Principal Dimensions				Mass (lb)
Cartridge Only	Cartridge, Bearing and Seals	G (in)	J (in)	L (in)		
01 C 01	01 BC 103 AT	3 15/16	1	3 3/8	4.4	
01 C 01	01 BC 104 AT	3 15/16	1	3 3/8	4.4	
01 C 01	01 BC 107 AT	3 15/16	1	3 3/8	4.4	
01 C 01	01 BC 108 AT	3 15/16	1	3 3/8	4.4	
01 C 02	01E BC 111 AT	4 5/8	1	3 13/16	5.5	
01 C 02	01E BC 112 AT	4 5/8	1	3 13/16	5.5	
01 C 02	01E BC 115 AT	4 5/8	1	3 13/16	5.5	
02 C 03	02 BC 115 AT	5 5/16	1 1/4	4 1/2	8.8	
01 C 02	01E BC 200 AT	4 5/8	1	3 13/16	5.5	
02 C 03	02 BC 200 AT	5 5/16	1 1/4	4 1/2	8.8	
01 C 03	01E BC 203 AT	5 5/16	1 1/4	4 1/8	7.0	
02 C 04	02 BC 203 AT	6 5/16	1 1/2	4 15/16	15.4	
01 C 03	01E BC 204 AT	5 5/16	1 1/4	4 1/8	7.0	
02 C 04	02 BC 204 AT	6 5/16	1 1/2	4 15/16	15.4	
01 C 03	01E BC 207 AT	5 5/16	1 1/4	4 1/8	7.0	
02 C 04	02 BC 207 AT	6 5/16	1 1/2	4 15/16	15.4	

1) Add 'EX' or 'GR' to reference for expansion type or fixed type respectively, eg:
 bearing: 01E B 207 EX
 cartridge: 01 C 03 EX
 bearing, cartridge and seals: 01E BC 207 EX AT
 complete unit: 01E BCP 207 EX AT
 Pillow blocks are common between expansion and fixed typed units.

2) Total available axial movement given. Maximum offset from centerline half this amount. 'Usual' axial movement denotes maximum recommended range of running positions of EX bearing for optimum performance. 'Maximum' axial movement denotes available movement before bearing strikes inside of standard Cooper cartridge.

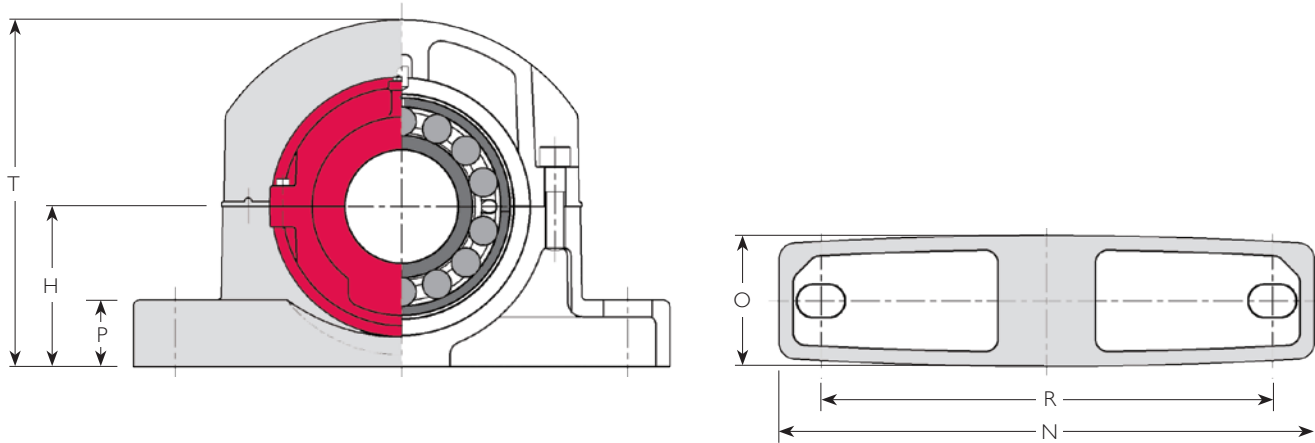

PILLOW BLOCK

References (I)		R					Bolts			Mass (lb)				Shaft Diameter d (in)		
Pillow Block Only	Complete Unit	H (in)	Min. (in)	Max. (in)	Ro (in)	S (in)	No.	Metric Size	Inch Size	N (in)	O (in)	P (in)	T (in)		Pillow Block Only	Complete Unit
P01	01 BCP 103 AT	2 3/8	6 3/4	7 1/2	-	-	2	M12	1/2"	9	2 3/8	7/8	5 1/2	5.5	12.5	1 3/16
P01	01 BCP 104 AT	2 3/8	6 3/4	7 1/2	-	-	2	M12	1/2"	9	2 3/8	7/8	5 1/2	5.5	12.5	1 1/4
P01	01 BCP 107 AT	2 3/8	6 3/4	7 1/2	-	-	2	M12	1/2"	9	2 3/8	7/8	5 1/2	5.5	12.5	1 7/16
P01	01 BCP 108 AT	2 3/8	6 3/4	7 1/2	-	-	2	M12	1/2"	9	2 3/8	7/8	5 1/2	5.5	12.5	1 1/2
P02	01E BCP 111 AT	2 3/4	8	8 15/16	-	-	2	M16	5/8"	10 5/8	2 3/8	1	6 1/4	7.0	15.8	1 11/16
P02	01E BCP 112 AT	2 3/4	8	8 15/16	-	-	2	M16	5/8"	10 5/8	2 3/8	1	6 1/4	7.0	15.8	1 3/4
P02	01E BCP 115 AT	2 3/4	8	8 15/16	-	-	2	M16	5/8"	10 5/8	2 3/8	1	6 1/4	7.0	15.8	1 15/16
P03	02 BCP 115 AT	3 5/32	8 7/8	9 1/2	-	-	2	M16	5/8"	11	2 3/4	1 1/4	7	10.8	24.0	2
P03	01E BCP 200 AT	2 3/4	8	8 15/16	-	-	2	M16	5/8"	10 5/8	2 3/8	1	6 1/4	7.0	15.8	2
P04	02 BCP 200 AT	3 5/32	8 7/8	9 1/2	-	-	2	M16	5/8"	11	2 3/4	1 1/4	7	10.8	24.0	2
P03	01E BCP 203 AT	3 5/32	8 7/8	9 1/2	-	-	2	M16	5/8"	11	2 3/4	1 1/4	7	10.8	21.8	2 3/16
P04	02 BCP 203 AT	3 3/4	10 1/4	11	-	-	2	M20	3/4"	13	3	1 1/2	8 1/8	15.2	37.2	2 3/16
P03	01E BCP 204 AT	3 5/32	8 7/8	9 1/2	-	-	2	M16	5/8"	11	2 3/4	1 1/4	7	10.8	21.8	2 1/4
P04	02 BCP 204 AT	3 3/4	10 1/4	11	-	-	2	M20	3/4"	13	3	1 1/2	8 1/8	15.2	37.2	2 1/4
P03	01E BCP 207 AT	3 5/32	8 7/8	9 1/2	-	-	2	M16	5/8"	11	2 3/4	1 1/4	7	10.8	21.8	2 7/16
P04	02 BCP 207 AT	3 3/4	10 1/4	11	-	-	2	M20	3/4"	13	3	1 1/2	8 1/8	15.2	37.2	2 7/16

3) Maximum fillet radii of abutments:

inner race: 3/64"

outer race: 1/64"

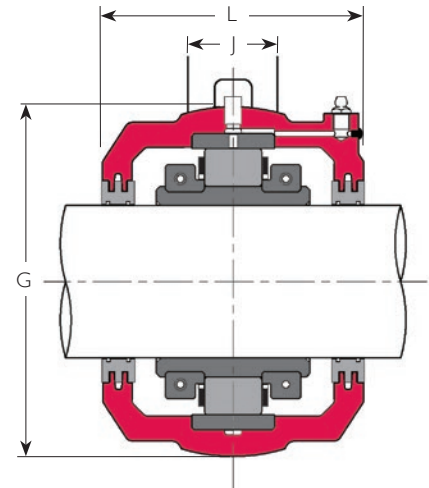
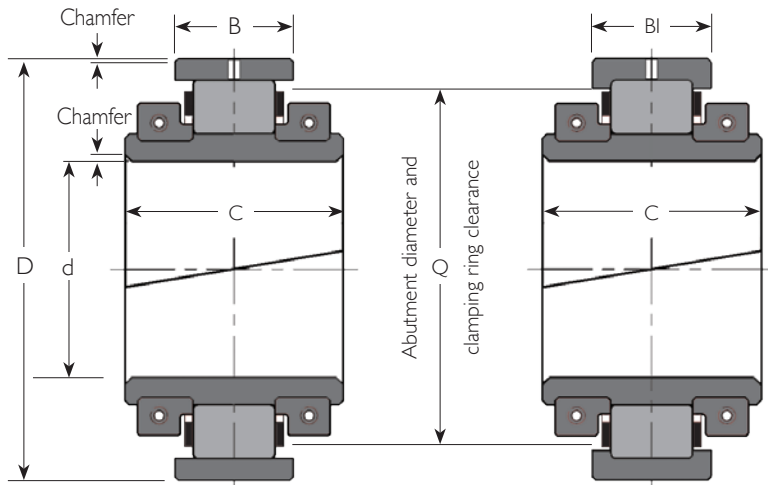

ROLLER BEARING

Shaft Dia. d (in)	Reference (1)	Bearing Ratings				Principal Dimensions					Axial Movement (2)		
		Cr (lb)	Cor (lb)	Ca (lb)	Max. Speed (rpm)	D (in)	C (in)	B (in)	BI (in)	Q (in)	Usual (in)	Max. (in)	Mass (lb)
2 1/2	01E B 208	30350	35290	1618	3940	4.500	2.193	1.063	1.063	4.13	3/16	3/16	4.0
	02 B 208	37770	43390	1978	3680	5.000	2.846	1.531	1.531	4.57	7/32	7/16	6.6
2 11/16	01E B 211	37320	44290	2427	3310	5.250	2.409	1.252	1.252	4.88	3/16	1/4	5.5
	02 B 211	51480	60250	2382	3080	5.875	3.252	1.815	1.815	5.43	1/4	17/32	11.0
2 3/4	01E B 212	37320	44290	2427	3310	5.250	2.409	1.252	1.252	4.88	3/16	1/4	5.5
	02 B 212	51480	60250	2382	3080	5.875	3.252	1.815	1.815	5.43	1/4	17/32	11.0
2 15/16	100 B 215	20460	28770	1573	4215	4.500	1.890	1.063	1.063	4.02	1/8	1/4	2.6
	01E B 215	37320	44290	2427	3310	5.250	2.409	1.252	1.252	4.88	3/16	1/4	5.5
3	02 B 215	51480	60250	2382	3080	5.875	3.252	1.815	1.815	5.43	1/4	17/32	11.0
	100 B 300	20460	28770	1573	4215	4.500	1.890	1.063	1.063	4.02	1/8	1/4	2.6
3 3/16	01E B 303	52600	67220	3057	2790	6.000	2.783	1.531	1.531	5.59	1/4	3/8	8.8
	02 B 303	62940	77550	4001	2520	6.688	3.531	1.906	1.906	6.14	9/32	9/16	15.4
3 1/4	01E B 304	52600	67220	3057	2790	6.000	2.783	1.531	1.531	5.59	1/4	3/8	8.8
	02 B 304	62940	77550	4001	2520	6.688	3.531	1.906	1.906	6.14	9/32	9/16	15.4

CARTRIDGE

Cartridge Only	References (1)	Principal Dimensions				Mass (lb)
		Cartridge, Bearing and Seals	G (in)	J (in)	L (in)	
01 C 03	01E BC 208 AT	5 5/16	1 1/4	4 1/8	7.0	
	02 BC 208 AT	6 3/16	1 1/2	4 15/16	15.4	
01 C 04	01E BC 211 AT	6 3/16	1 1/2	4 1/2	12.1	
	02 BC 211 AT	7	2	5 1/2	19.8	
01 C 04	01E BC 212 AT	6 3/16	1 1/2	4 1/2	12.1	
	02 BC 212 AT	7	2	5 1/2	19.8	
100 C 03	100 BC 215 AT	5 5/16	1 1/4	4 1/8	7.9	
	01E BC 215 AT	6 3/16	1 1/2	4 1/2	12.1	
02 C 05	02 BC 215 AT	7	2	5 1/2	19.8	
	100 C 03	100 BC 300 AT	5 5/16	1 1/4	4 1/8	7.9
01 C 04	01E BC 300 AT	6 3/16	1 1/2	4 1/2	12.1	
	02 BC 300 AT	7	2	5 1/2	19.8	
01 C 05	01E BC 303 AT	7	2	5 3/8	15.4	
	02 BC 303 AT	8	2	6 1/16	22	
01 C 05	01E BC 304 AT	7	2	5 3/8	15.4	
	02 BC 304 AT	8	2	6 1/16	22	

1) Add 'EX' or 'GR' to reference for expansion type or fixed type respectively, eg:
 bearing: 01E B 215 EX
 cartridge: 01 C 04 EX
 bearing, cartridge and seals: 01E BC 215 EX AT
 complete unit: 01E BCP 215 EX AT
 Pillow blocks are common between expansion and fixed typed units.

2) Total available axial movement given. Maximum offset from centerline half this amount. 'Usual' axial movement denotes maximum recommended range of running positions of EX bearing for optimum performance. 'Maximum' axial movement denotes available movement before bearing strikes inside of standard Cooper cartridge.

2 BOLT

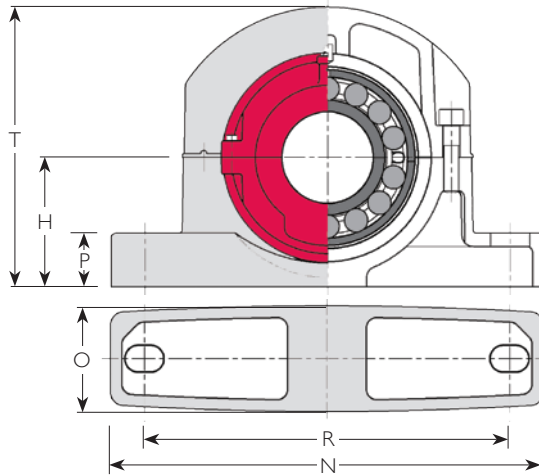

4 BOLT

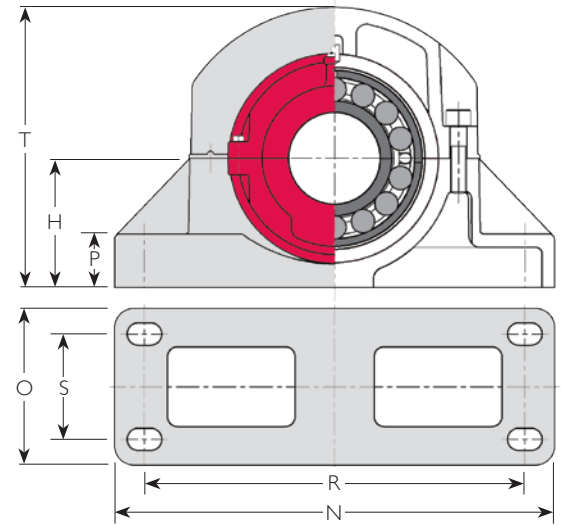

PILLOW BLOCK

References (I)		R		Bolts							Mass (lb)		Shaft Diameter d (in)		
Pillow Block Only	Complete Unit	H (in)	Min. (in)	Max. (in)	Ro (in)	S (in)	No.	Metric Size	Inch Size	N (in)	O (in)	P (in)		T (in)	Pillow Block Only
P03	01E BCP 208 AT	3 5/32	8 7/8	9 1/2	-	-	2	M16	5/8"	11 1/2	2 3/4	1 1/4	7	10.8	21.8
P04	02 BCP 208 AT	3 3/4	10 1/4	11	-	-	2	M20	3/4"	13	3	1 1/2	8 1/8	15.2	37.2
P04	01E BCP 211 AT	3 3/4	10 1/4	11	-	-	2	M20	3/4"	13	3	1 1/2	8 1/8	15.2	32.8
P0510	02 BC4P 211 AT	4 13/32	12 7/16	13 3/8	-	3 1/2	4	M20	7/8"	15	5 1/2	1 3/4	10	33.6	64.4
P04	01E BCP 212 AT	3 3/4	10 1/4	11	-	-	2	M20	3/4"	13	3	1 1/2	8 1/8	15.2	32.8
P0510	02 BC4P 212 AT	4 13/32	12 7/16	13 3/8	-	3 1/2	4	M20	7/8"	15	5 1/2	1 3/4	10	33.6	64.4
P03	100 BCP 215 AT	3 5/32	8 7/8	9 1/2	-	-	2	M16	5/8"	11	2 3/4	1 1/4	7 1/16	10.8	21.3
P04	01E BCP 215 AT	3 3/4	10 1/4	11	-	-	2	M20	3/4"	13	3	1 1/2	8 1/8	15.2	32.8
P0510	02 BC4P 215 AT	4 13/32	12 7/16	13 3/8	-	3 1/2	4	M20	3/4"	15	5 1/2	1 3/4	10	33.6	64.4
P03	100 BCP 300 AT	3 5/32	8 7/8	9 1/2	-	-	2	M16	5/8"	11	2 3/4	1 1/4	7 1/16	10.8	21.3
P04	01E BCP 300 AT	3 3/4	10 1/4	11	-	-	2	M20	3/4"	13	3	1 1/2	8 1/8	15.2	32.8
P0510	02 BC4P 300 AT	4 13/32	12 7/16	13 3/8	-	3 1/2	4	M20	3/4"	15	5 1/2	1 3/4	10	33.6	64.4
P0510	01E BC4P 303 AT	4 13/32	12 7/16	13 3/8	-	3 1/2	4	M20	3/4"	15	5 1/2	1 3/4	10	33.6	57.8
P0613	02 BC4P 303 AT	4 15/16	14	15	-	4	4	M20	3/4"	16 3/4	6	2	10 3/4	44.4	81.8
P0510	01E BC4P 304 AT	4 13/32	12 7/16	13 3/8	-	3 1/2	4	M20	3/4"	15	5 1/2	1 3/4	10	33.6	57.8
P0613	02 BC4P 304 AT	4 15/16	14	15	-	4	4	M20	3/4"	16 3/4	6	2	10 3/4	44.4	81.8

3) Maximum fillet radii of abutments:
 inner race: 3/64"
 outer race: 1/64"

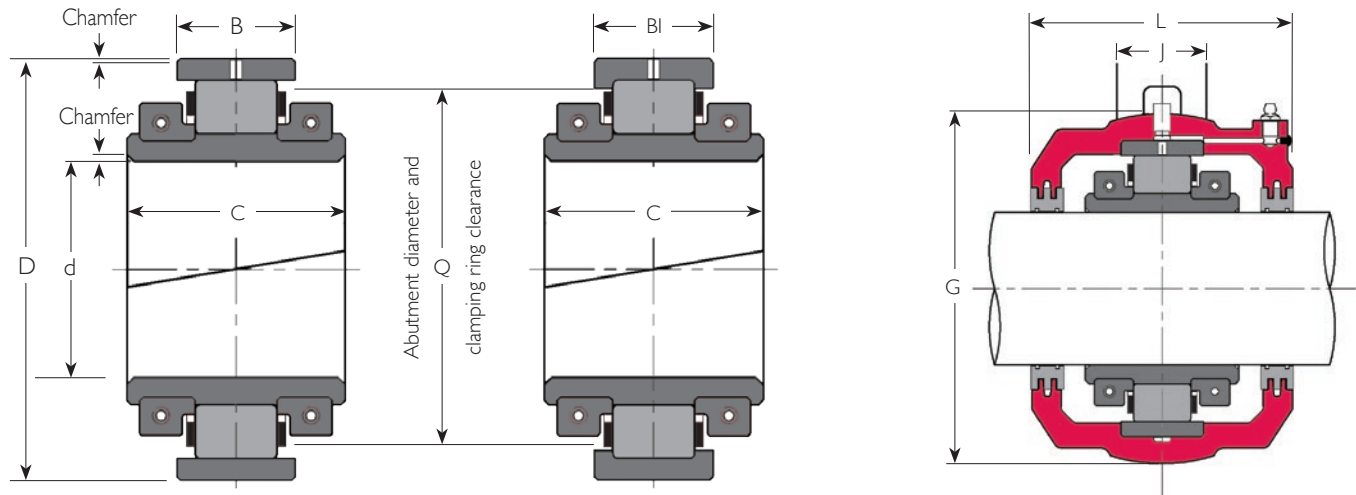

ROLLER BEARING

Shaft Dia. d (in)	Reference (1)	Bearing Ratings				Principal Dimensions					Axial Movement (2)		
		Cr (lb)	Cor (lb)	Ca (lb)	Max. Speed (rpm)	D (in)	C (in)	B (in)	BI (in)	Q (in)	Usual (in)	Max. (in)	Mass (lb)
3 7/16	100 B 307	31920	46950	2765	4190	5.205	2.362	1.252	1.252	4.72	3/16	1/4	4.6
	01E B 307	52600	67220	3057	2790	6.000	2.783	1.531	1.531	5.59	1/4	3/8	8.8
	02 B 307	62940	77560	4001	2520	6.688	3.531	1.906	1.906	6.14	9/32	9/16	15.4
3 1/2	01E B 308	52600	67220	3057	2790	6.000	2.783	1.531	1.531	5.59	1/4	3/8	8.8
	02 B 308	62940	77560	4001	2520	6.688	3.531	1.906	1.906	6.14	9/32	9/16	15.4
3 11/16	01E B 311	71940	94640	4406	2340	6.875	3.189	1.783	1.783	6.38	9/32	13/32	13.2
	02 B 311	81380	102500	5620	2130	7.625	3.626	2.031	2.031	7.01	5/16	17/32	19.8
3 3/4	01E B 312	71940	94640	4406	2340	6.875	3.189	1.783	1.783	6.38	9/32	13/32	13.2
	02 B 312	81380	102500	5620	2130	7.625	3.626	2.031	2.031	7.01	5/16	17/32	19.8
3 15/16	100 B 315	42940	64740	4114	3090	6.000	2.559	1.531	1.531	5.51	1/4	3/8	6.2
	01E B 315	71940	94640	4406	2340	6.875	3.189	1.783	1.783	6.38	9/32	13/32	13.2
	02 B 315	81380	102500	5620	2130	7.625	3.626	2.031	2.031	7.01	5/16	17/32	19.8
	03 B 315	137100	153800	7014	1820	10.000	5.354	3.315	3.315	8.62	7/16	1 1/8	66.0
4	100 B 400	42940	64740	4114	3090	6.000	2.559	1.531	1.531	5.51	1/4	3/8	6.2
	01E B 400	71940	94640	4406	2340	6.875	3.189	1.783	1.783	6.38	9/32	13/32	13.2
	02 B 400	81380	102500	5620	2130	7.625	3.626	2.031	2.031	7.01	5/16	17/32	19.8
	03 B 400	137100	153800	7014	1820	10.000	5.354	3.315	3.315	8.62	7/16	1 1/8	66.0

1) Add 'EX' or 'GR' to reference for expansion type or fixed type respectively, eg:
 bearing: 01E B 307 EX
 cartridge: 01 C 05 EX
 bearing, cartridge and seals: 01E BC 307 EX AT
 complete unit: 01E BCP 307 EX AT
 Pillow blocks are common between expansion and fixed typed units.

CARTRIDGE

References (1)	Principal Dimensions				Mass (lb)	
	Cartridge Only	Cartridge, Bearing and Seals	G (in)	J (in)		L (in)
100 C 04 01 C 05 02 C 06	100 BC 307 AT	100 BC 307 AT	6 3/16	1 1/2	4 1/2	11.9
	01E BC 307 AT	01E BC 307 AT	7	2	5 3/8	15.4
	02 BC 307 AT	02 BC 307 AT	8	2	6 1/16	22
01 C 05 02 C 06	01E BC 308 AT	01E BC 308 AT	7	2	5 3/8	15.4
	02 BC 308 AT	02 BC 308 AT	8	2	6 1/16	22
01 C 06 02 C 07	01E BC 311 AT	01E BC 311 AT	8	2	5 1/4	17.6
	02 BC 311 AT	02 BC 311 AT	9 1/8	2 1/2	5 3/4	26.4
01 C 06 02 C 07	01E BC 312 AT	01E BC 312 AT	8	2	5 1/4	17.6
	02 BC 312 AT	02 BC 312 AT	9 1/8	2 1/2	5 3/4	26.4
100 C 05 01 C 06 02 C 07 03 C 54	100 BC 315 AT	100 BC 315 AT	7	2	5 3/8	16.3
	01E BC 315 AT	01E BC 315 AT	8	2	5 1/4	17.6
	02 BC 315 AT	02 BC 315 AT	9 1/8	2 1/2	5 3/4	26.4
	03 BC 315 AT	03 BC 315 AT	12 1/8	3 3/4	8 1/8	90.2
100 C 05 01 C 06 02 C 07	100 BC 400 AT	100 BC 400 AT	7	2	5 3/8	16.3
	01E BC 400 AT	01E BC 400 AT	8	2	5 1/4	17.6
	02 BC 400 AT	02 BC 400 AT	9 1/8	2 1/2	5 3/4	26.4
03 C 54	03 BC 400 AT	03 BC 400 AT	12 1/8	3 3/4	8 1/8	90.2

2) Total available axial movement given. Maximum offset from centerline half this amount. 'Usual' axial movement denotes maximum recommended range of running positions of EX bearing for optimum performance. 'Maximum' axial movement denotes available movement before bearing strikes inside of standard Cooper cartridge.

2 BOLT

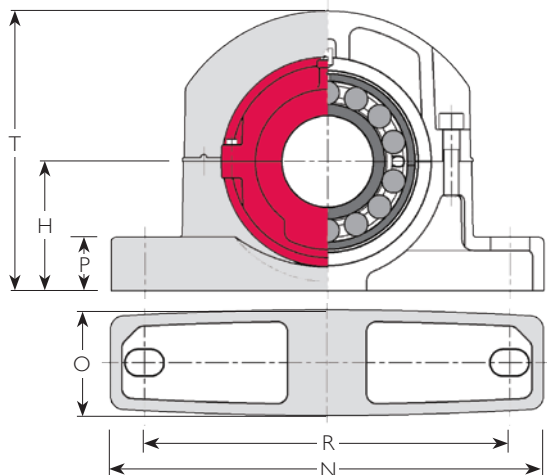

4 BOLT

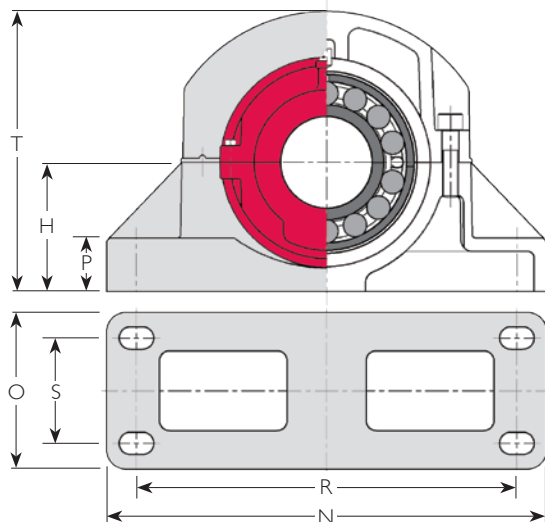

PILLOW BLOCK

References (I)		R		Bolts						Mass (lb)		Shaft Diameter d (in)			
Pillow Block Only	Complete Unit	H (in)	Min. (in)	Max. (in)	Ro (in)	S (in)	No.	Metric Size	Inch Size	N (in)	O (in)		P (in)	T (in)	Pillow Block Only
P04	100 BCP 307 AT	3 3/4	10 1/4	11	-	-	2	M20	3/4"	13	3	1 1/2	8 1/8	15.2	31.7
P0510	01E BC4P 307 AT	4 13/32	12 7/16	13 3/8	-	3 1/2	4	M20	3/4"	15	5 1/2	1 3/4	10	33.6	57.8
P0613	02 BC4P 307 AT	4 15/16	14	15	-	4	4	M20	3/4"	16 3/4	6	2	10 3/4	44.4	81.8
P0510	01E BC4P 308 AT	4 13/32	12 5/16	13 3/8	-	3 1/2	4	M20	3/4"	15	5 1/2	1 3/4	10	33.6	57.8
P0613	02 BC4P 308 AT	4 15/16	14	15	-	4	4	M20	3/4"	16 3/4	6	2	10 3/4	44.4	81.8
P0613	01E BC4P 311 AT	4 15/16	14	15	-	4	4	M20	3/4"	16 3/4	6	2	10 3/4	44.4	75.2
P0710	02 BC4P 311 AT	5 5/8	15 3/4	16 11/16	-	4 1/2	4	M20	3/4"	18 3/4	6 3/4	2 3/8	12 3/8	53.2	99.4
P0613	01E BC4P 312 AT	4 15/16	13 7/16	15	-	4	4	M20	3/4"	16 3/4	6	2	10 3/4	44.4	75.2
P0710	02 BC4P 312 AT	5 5/8	15 3/4	16 11/16	-	4 1/2	4	M20	3/4"	18 3/4	6 3/4	2 3/8	12 3/8	53.2	99.4
P05	100 BCP 315 AT	4 13/32	12 9/32	12 29/32	-	-	2	M24	7/8"	15	3 15/64	1 3/4	10	29.3	51.7
P0613	01E BC4P 315 AT	4 15/16	14	15	-	4	4	M20	3/4"	16 3/4	6	2	10 3/4	44.4	75.2
P0710	02 BC4P 315 AT	5 5/8	15 3/4	16 11/32	-	4 1/2	4	M20	3/4"	18 3/4	6 3/4	2 3/8	12 3/8	53.2	99.4
P54	03 BCP 315 AT	7 17/32	16 3/4	17 3/4	-	3 1/4	4	M24	7/8"	20 3/4	6	1 1/2	16	134	290
P05	100 BCP 400 AT	4 13/32	12 9/32	12 29/32	-	-	2	M24	7/8"	15	3 15/64	1 3/4	10	29.3	51.7
P0613	01E BC4P 400 AT	4 15/16	14	15	-	4	4	M20	3/4"	16 3/4	6	2	10 3/4	44.4	75.2
P0710	02 BC4P 400 AT	5 5/8	15 3/4	16 11/32	-	4 1/2	4	M20	3/4"	18 3/4	6 3/4	2 3/8	12 3/8	53.2	99.4
P54	03 BCP 400 AT	7 17/32	16 3/4	17 3/4	-	3 1/4	4	M24	7/8"	20 1/4	6	1 1/2	16	134	290

- 3) Maximum fillet radii of abutments:
 inner race: up to and including 3 1/2" shaft size: 3/64"
 over 3 1/2" shaft size: 5/64"
 outer race: 01E and 02 Series up to and including 3 1/2" shaft size
 100 Series: 1/64"
 01E and 02 Series over 3 1/2" shaft size 1/32"
 03 Series: 5/6"

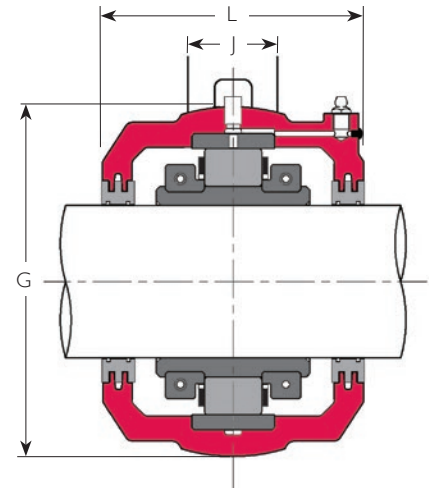
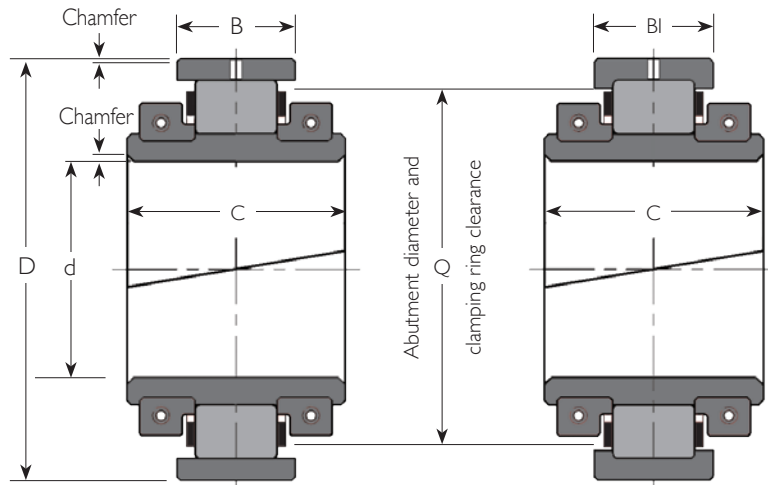

ROLLER BEARING

Shaft Dia. d (in)	Reference (1)	Bearing Ratings				Principal Dimensions					Axial Movement (2)		
		Cr (lb)	Cor (lb)	Ca (lb)	Max. Speed (rpm)	D (in)	C (in)	B (in)	BI (in)	Q (in)	Usual (in)	Max. (in)	Mass (lb)
4 3/16	01 B 403	68790	91490	4184	1970	8.000	3.343	1.846	1.846	7.17	9/32	1/2	22.4
	02 B 403	102100131100	7014	1820	9.000	3.937	2.252	2.252	7.95	3/8	17/32	35.2	
4 7/16	100 B 407	62790	95760	4991	2750	6.875	3.150	1.783	1.783	6.30	9/32	3/8	10.1
	01 B 407	68790	91490	4181	1970	8.000	3.343	1.846	1.846	7.17	9/32	1/2	22.4
	02 B 407	102100131100	7014	1820	9.000	3.937	2.252	2.252	7.95	3/8	17/32	35.2	
	03 B 407	138000156900	8812	1640	10.500	5.787	3.437	3.437	9.13	7/16	1 3/16	79.2	
4 1/2	100 B 408	62790	95760	4991	2750	6.875	3.150	1.783	1.783	6.30	9/32	3/8	10.1
	01 B 408	68790	91490	4181	1970	8.000	3.343	1.846	1.846	7.17	9/32	1/2	22.4
	02 B 408	102100131100	7014	1820	9.000	3.937	2.252	2.252	7.95	3/8	17/32	35.2	
	03 B 408	138000156900	8812	1640	10.500	5.787	3.437	3.437	9.13	7/16	1 3/16	79.2	
4 15/16	100 B 415	62940	97340	5350	2480	8.000	3.346	1.846	1.846	7.09	9/32	7/16	16.3
	01 B 415	79800	108800	4991	1740	8.750	3.531	2.126	2.126	7.87	9/32	19/32	28.2
	02 B 415	123000160300	8587	1600	10.000	4.500	2.500	2.500	8.82	3/8	19/32	44.0	
	03 B 415	15870019150011020	1500	11.000	5.512	2.878	3.315	9.65	7/16	11/16	79.2		
5	100 B 500	62940	97340	5350	2480	8.000	3.346	1.846	1.846	7.09	9/32	7/16	16.3
	01 B 500	79800	108800	4991	1740	8.750	3.531	2.126	2.126	7.87	9/32	19/32	28.2
	02 B 500	123000160300	8587	1600	10.000	4.500	2.500	2.500	8.82	3/8	19/32	44.0	
	03 B 500	15870019150011020	1500	11.000	5.512	2.878	3.315	9.65	7/16	11/16	79.2		

CARTRIDGE

References (1)	Principal Dimensions				
	Cartridge Only	Cartridge, Bearing and Seals	G (in)	J (in)	L (in)
01 C 07	01 BC 403 AT	9 1/8	2 1/2	5 9/16	26.2
02 C 08	02 BC 403 AT	10 1/2	3	6 3/8	41.8
100 C 06	100 BC 407 AT	8	2	5 1/4	17.4
01 C 07	01 BC 407 AT	9 1/8	2 1/2	5 9/16	26.2
02 C 08	02 BC 407 AT	10 1/2	3	6 3/8	41.8
03 C 55	03 BC 407 AT	12 3/4	4	8 3/4	101
100 C 06	100 BC 408 AT	8	2	5 1/4	17.4
01 C 07	01 BC 408 AT	9 1/8	2 1/2	5 9/16	26.2
02 C 08	02 BC 408 AT	10 1/2	3	6 3/8	41.8
03 C 55	03 BC 408 AT	12 3/4	4	8 3/4	101
100 C 07	100 BC 415 AT	9 1/8	2 1/2	5 9/16	26.2
01 C 08	01 BC 415 AT	10 1/2	3	6 1/8	42.9
02 C 10	02 BC 415 AT	11 5/8	3 1/4	7 1/4	57.2
03 C 56	03 BC 415 AT	12 3/4	4	8 3/4	106
100 C 07	100 BC 500 AT	9 1/8	2 1/2	5 9/16	24.2
01 C 08	01 BC 500 AT	10 1/2	3	6 1/8	42.9
02 C 10	02 BC 500 AT	11 5/8	3 1/4	7 1/4	57.2
03 C 56	03 BC 500 AT	12 3/4	4	8 3/4	106

1) Add 'EX' or 'GR' to reference for expansion type or fixed type respectively, eg:
 bearing: 01 B 407 EX
 cartridge: 01 C 07 EX
 bearing, cartridge and seals: 01 BC 407 EX AT
 complete unit: 01 BCP 407 EX AT
 Pillow blocks are common between expansion and fixed typed units.

2) Total available axial movement given. Maximum offset from centerline half this amount. 'Usual' axial movement denotes maximum recommended range of running positions of EX bearing for optimum performance. 'Maximum' axial movement denotes available movement before bearing strikes inside of standard Cooper cartridge.

2 BOLT

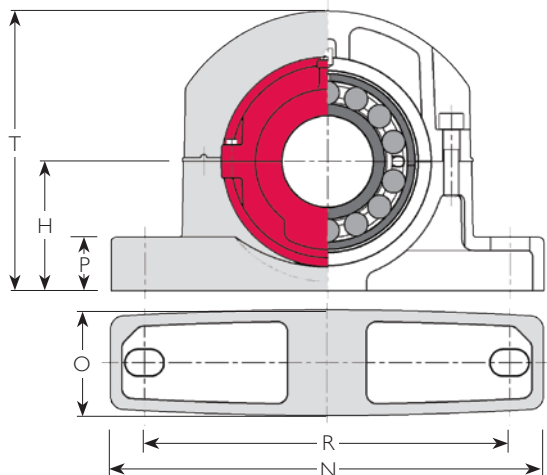

4 BOLT

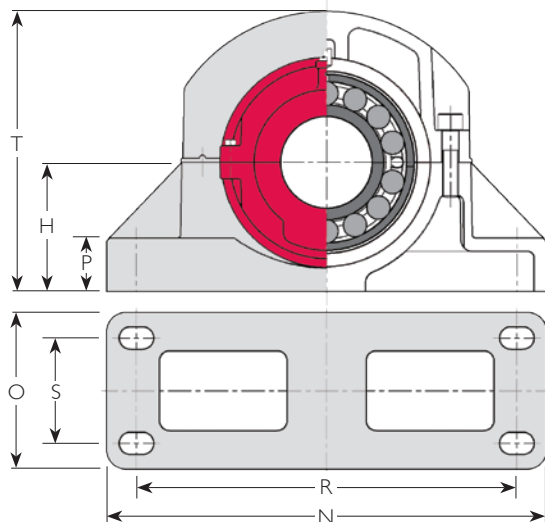

PILLOW BLOCK

References (I)		R		Bolts						Mass (lb)		Shaft Diameter d (in)			
Pillow Block Only	Complete Unit	H (in)	Min. (in)	Max. (in)	Ro (in)	S (in)	No.	Metric Size	Inch Size	N (in)	O (in)		P (in)	T (in)	Pillow Block Only
P0710	01 BC4P 403 AT	5 5/8	15 3/4	16 11/16	-	4 1/2	4	M20	3/4"	18 3/4	6 3/4	2 3/8	12 3/8	53.2	102
P08	02 BCP 403 AT	6 3/8	17 1/4	18 3/16	-	4 3/4	4	M24	7/8"	20	7	1 1/2	14 3/4	95.3	172
P06	100 BCP 407 AT	4 15/16	13 15/32	14 13/32	-	-	2	M24	7/8"	16 17/32	4 1/64	2	10 3/4	32.3	59.8
P0710	01 BC4P 407 AT	5 5/8	15 3/4	16 11/16	-	4 1/2	4	M20	3/4"	18 3/4	6 3/4	2 3/8	12 3/8	53.2	102
P08	02 BCP 407 AT	6 3/8	17 1/4	18 3/16	-	4 3/4	4	M24	7/8"	20	7	1 1/2	14 3/4	95.3	172
P55	03 BCP 407 AT	7 3/4	17 1/2	18 1/2	-	3 7/16	4	M24	1"	21	6 1/2	1 1/2	16 3/4	152	332
P06	100 BCP 408 AT	4 15/16	13 15/32	14 13/32	-	-	2	M24	7/8"	16 17/32	4 1/64	2	10 3/4	32.3	59.8
P0710	01 BC4P 408 AT	5 5/8	15 3/4	16 11/16	-	4 1/2	4	M20	3/4"	18 3/4	6 3/4	2 3/8	12 3/8	53.2	102
P08	02 BCP 408 AT	6 3/8	17 1/4	18 3/16	-	4 3/4	4	M24	7/8"	20	7	1 1/2	14 3/4	95.3	172
P55	03 BCP 408 AT	7 3/4	17 1/2	18 1/2	-	3 7/16	4	M24	1"	21	6 1/2	1 1/2	16 3/4	152	332
P07	100 BCP 415 AT	5 5/8	14 23/32	16 9/64	-	-	2	M24	7/8"	18 3/8	4 23/32	2 3/8	12 3/8	45.3	85.8
P08	01 BCP 415 AT	6 3/8	17 1/4	18 3/16	-	4 3/4	4	M24	7/8"	20	7	1 1/2	14 3/4	95.3	166
P10	02 BCP 415 AT	7 1/8	19	20	-	4 3/4	4	M24	7/8"	22	7	1 5/8	16 1/4	119	220
P56	03 BCP 415 AT	8	18	19	-	3 3/4	4	M24	1"	21 1/2	6 1/2	1 7/8	17 1/8	163	348
P07	100 BCP 500 AT	5 5/8	14 23/32	16 9/64	-	-	2	M24	7/8"	18 3/8	4 23/32	2 3/8	12 3/8	45.3	85.8
P08	01 BCP 500 AT	6 3/8	17 1/4	18 3/16	-	4 3/4	4	M24	7/8"	20	7	1 1/2	14 3/4	95.3	166
P10	02 BCP 500 AT	7 1/8	19	20	-	4 3/4	4	M24	7/8"	22	7	1 5/8	16 1/4	119	220
P56	03 BCP 500 AT	8	18	19	-	3 3/4	4	M24	1"	21 1/2	6 1/2	1 7/8	17 1/8	163	348

3) Maximum fillet radii of abutments:

inner race: 5/64"

outer race: 100, 01 and 02 Series: 1/32"

03 Series: 5/64"

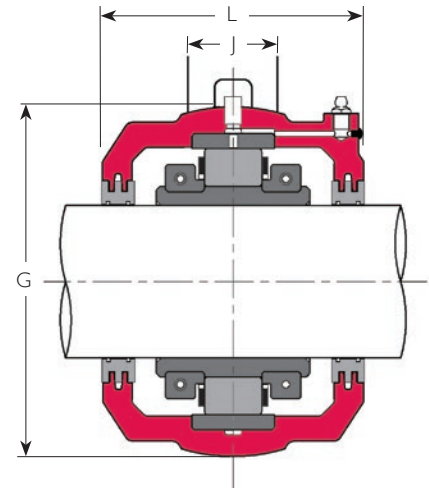
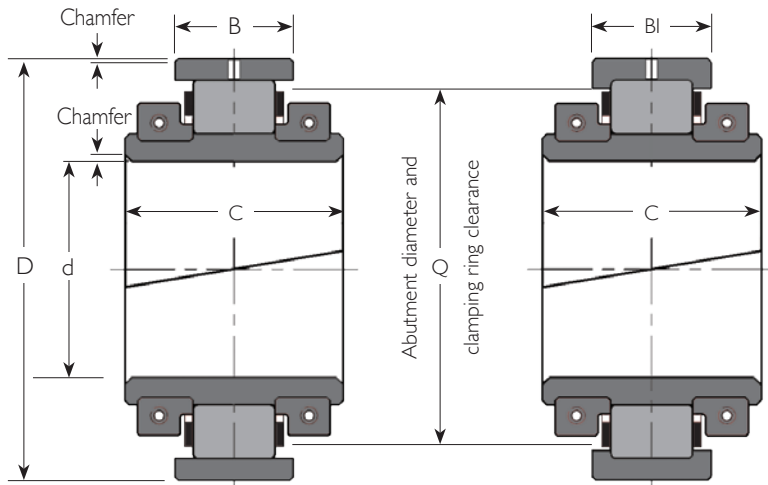

ROLLER BEARING

Shaft Dia. d (in)	Reference (1)	Bearing Ratings				Principal Dimensions					Axial Movement (2)		
		Cr (lb)	Cor (lb)	Ca (lb)	Max. Speed (rpm)	D (in)	C (in)	B (in)	BI (in)	Q (in)	Usual (in)	Max. (in)	Mass (lb)
5 3/16	01 B 503	88570	121800	5800	1570	9.500	3.874	2.189	2.189	8.50	5/16	5/8	33.0
	02 B 503	136700	181600	10210	1450	10.750	4.626	2.626	2.626	9.45	3/8	19/32	52.8
5 7/16	100 B 507	74310	116900	6856	2250	8.750	3.543	2.126	2.126	7.68	9/32	1/2	20.5
	01 B 507	88570	121800	5800	1570	9.500	3.874	2.189	2.189	8.50	5/16	5/8	33.0
	02 B 507	136700	181600	10210	1450	10.750	4.626	2.626	2.626	9.45	3/8	19/32	52.8
	03 B 507	199200	240300	13220	1340	12.000	5.787	3.126	3.563	10.63	1/2	11/16	96.8
5 1/2	100 B 508	74310	116900	6856	2250	8.750	3.543	2.126	2.126	7.68	9/32	1/2	20.5
	01 B 508	88570	121800	5800	1570	9.500	3.874	2.189	2.189	8.50	5/16	5/8	33.0
	02 B 508	136700	181600	10210	1450	10.750	4.626	2.626	2.626	9.45	3/8	19/32	52.8
	03 B 508	199200	240300	13220	1340	12.000	5.787	3.126	3.563	10.63	1/2	11/16	96.8
5 15/16	100 B 515	89250	136200	7059	2060	9.500	3.543	2.189	2.189	8.46	5/16	5/8	22.9
	01 B 515	96210	138500	6609	1450	10.000	3.874	2.189	2.189	9.06	5/16	5/8	36.5
	02 B 515	162800	225900	11780	1320	11.500	4.874	2.689	2.689	10.16	3/8	19/32	63.8
	03 B 515	223500	272700	15600	1220	13.000	6.299	3.189	3.815	11.50	1/2	5/8	125
6	100 B 600	89250	136200	7059	2060	9.500	3.543	2.189	2.189	8.46	5/16	5/8	22.9
	01 B 600	96210	138500	6609	1450	10.000	3.874	2.189	2.189	9.06	5/16	5/8	36.5
	02 B 600	162800	225900	11780	1320	11.500	4.874	2.689	2.689	10.16	3/8	19/32	63.8
	03 B 600	223500	272700	15600	1220	13.000	6.299	3.189	3.815	11.50	1/2	3/8	125

CARTRIDGE

References (1)	Principal Dimensions	Mass (lb)		
			Cartridge Only	Cartridge, Bearing and Seals
01 C 09	01 BC 503 AT	45.8		
02 C 30	02 BC 503 AT	72.6		
100 C 08	100 BC 507 AT	40.5		
01 C 09	01 BC 507 AT	45.8		
02 C 30	02 BC 507 AT	72.6		
03 C 57	03 BC 507 AT	114		
100 C 08	100 BC 508 AT	40.5		
01 C 09	01 BC 508 AT	45.8		
02 C 30	02 BC 508 AT	72.6		
03 C 57	03 BC 508 AT	114		
100 C 09	100 BC 515 AT	42.7		
01 C 10	01 BC 515 AT	53.7		
02 C 31	02 BC 515 AT	85.8		
03 C 58	03 BC 515 AT	154		
100 C 09	100 BC 600 AT	42.7		
01 C 10	01 BC 600 AT	53.7		
02 C 31	02 BC 600 AT	85.8		
03 C 58	03 BC 600 AT	154		

1) Add 'EX' or 'GR' to reference for expansion type or fixed type respectively, eg:
 bearing: 01 B 507 EX
 cartridge: 01 C 09 EX
 bearing, cartridge and seals: 01 BC 507 EX AT
 complete unit: 01 BCP 507 EX AT
 Pillow blocks are common between expansion and fixed typed units.

2) Total available axial movement given. Maximum offset from centerline half this amount. 'Usual' axial movement denotes maximum recommended range of running positions of EX bearing for optimum performance. 'Maximum' axial movement denotes available movement before bearing strikes inside of standard Cooper cartridge.

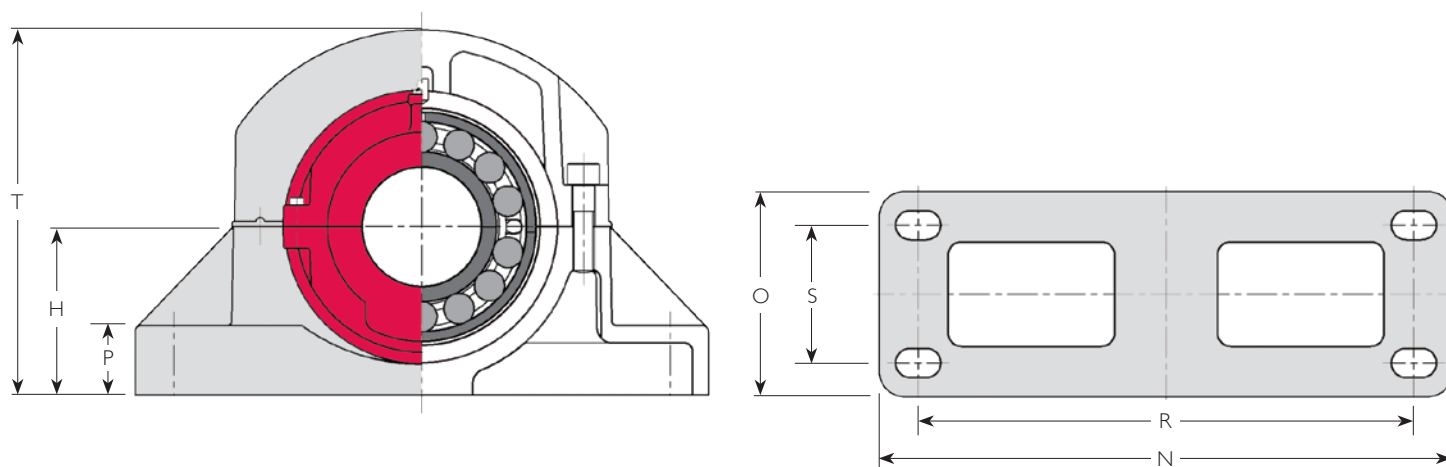

PILLOW BLOCK

References (I)		R					Bolts				Mass (lb)				Shaft Diameter d (in)	
Pillow Block Only	Complete Unit	H (in)	Min. (in)	Max. (in)	Ro (in)	S (in)	No.	Metric Size	Inch Size	N (in)	O (in)	P (in)	T (in)	Pillow Block Only		Complete Unit
P09	01 BCP 503 AT	7 1/8	18 1/2	19 1/2	-	4 3/4	4	M24	7/8"	22	7	1 5/8	15 15/16	114	193	5 3/16
P30	02 BCP 503 AT	8	21	22	-	4 3/4	4	M24	1"	24	7	2	18 1/8	167	293	
P08	100 BCP 507 AT	6 3/8	17 1/4	18 3/16	-	4 3/4	4	M24	7/8"	20	7	1 1/2	14 5/8	95.3	156	5 7/16
P09	01 BCP 507 AT	7 1/8	18 1/2	19 1/2	-	4 3/4	4	M24	7/8"	22	7	1 5/8	15 15/16	114	193	
P30	02 BCP 507 AT	8	21	22	-	4 3/4	4	M24	1"	24	7	2	18 1/8	167	293	
P57	03 BCP 507 AT	9	19 1/2	21	-	4	4	M30	1 1/4"	24 1/2	7	2 1/8	19 1/8	213	425	
P08	100 BCP 508 AT	6 3/8	17 1/4	18 3/16	-	4 3/4	4	M24	7/8"	20	7	1 1/2	14 5/8	95.3	156	5 1/2
P09	01 BCP 508 AT	7 1/8	18 1/2	19 1/2	-	4 3/4	4	M24	7/8"	22	7	1 5/8	15 15/16	114	193	
P30	02 BCP 508 AT	8	21	22	-	4 3/4	4	M24	1"	24	7	2	18 1/8	167	293	
P57	03 BCP 508 AT	9	19 1/2	21	-	4	4	M30	1 1/4"	24 1/2	7	2 1/8	19 1/8	213	425	
P09	100 BCP 515 AT	7 1/8	18 1/2	19 1/2	-	4 3/4	4	M24	7/8"	22	7	1 5/8	15 15/16	114	180	5 15/16
P10	01 BCP 515 AT	7 1/8	19	20	-	4 3/4	4	M24	7/8"	22	7	1 5/8	16 5/16	119	209	
P31	02 BCP 515 AT	8 1/4	21 1/2	22 1/2	-	5	4	M24	1"	25	8	2	18 1/2	183	332	
P58	03 BCP 515 AT	10	21 1/4	22 3/4	-	4 3/4	4	M30	1 1/4"	26 1/4	8	2 1/4	21 1/16	312	592	
P09	100 BCP 600 AT	7 1/8	18 1/2	19 1/2	-	4 3/4	4	M24	7/8"	22	7	1 5/8	15 15/16	114	180	6
P10	01 BCP 600 AT	7 1/8	19	20	-	4 3/4	4	M24	7/8"	22	7	1 5/8	16 5/16	119	209	
P31	02 BCP 600 AT	8 1/4	21 1/2	22 1/2	-	5	4	M24	1"	25	8	2	18 1/2	183	332	
P58	03 BCP 600 AT	10	21 1/4	22 3/4	-	4 3/4	4	M30	1 1/4"	26 1/4	8	2 1/4	21 1/16	312	592	

3) Maximum fillet radii of abutments:

inner race: 5/64"

outer race: 100, 01 and 02 Series: 1/32"

03 Series: 5/64"

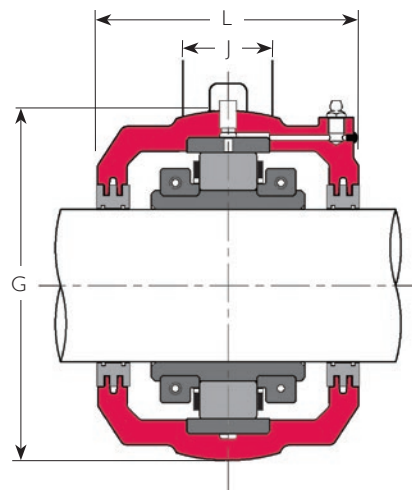
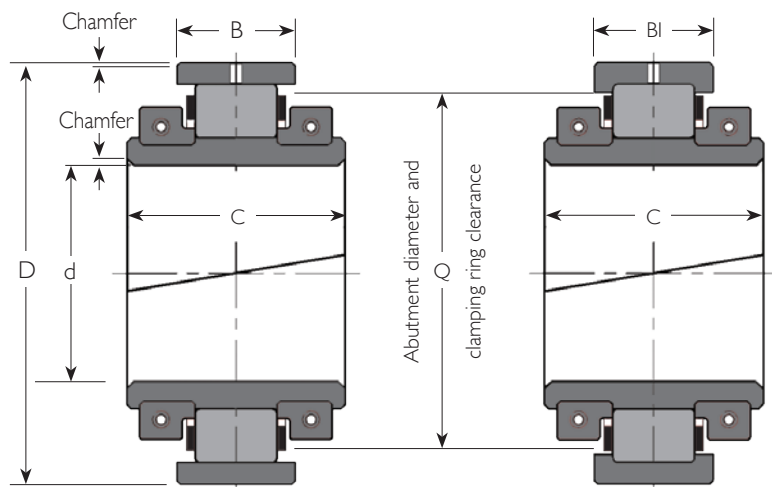

ROLLER BEARING

Shaft Dia. d (in)	Reference (1)	Bearing Ratings				Principal Dimensions					Axial Movement (2)		Mass (lb)
		Cr (lb)	Cor (lb)	Ca (lb)	Max. Speed (rpm)	D (in)	C (in)	B (in)	BI (in)	Q (in)	Usual (in)	Max. (in)	
6 7/16	01E B 607	133500	194000	12710	1320	10.750	4.291	2.374	2.374	9.76	15/16	11/16	46.2
	02E B 607	199300	283700	16020	1200	12.500	5.512	3.280	3.280	11.02	7/16	1	85.8
	03 B 607	259900	351600	17800	1110	14.000	6.732	4.063	4.063	12.13	9/16	1 1/4	158
6 1/2	01E B 608	133500	194000	12710	1320	10.750	4.291	2.374	2.374	9.76	15/16	11/16	46.2
	02E B 608	199300	283700	16020	1200	12.500	5.512	3.280	3.280	11.02	7/16	1	85.8
	03 B 608	259900	351600	17800	1110	14.000	6.732	4.063	4.063	12.13	9/16	1 1/4	158
6 15/16	01E B 615	125100	190000	11730	1220	11.250	4.291	2.185	2.185	10.24	15/16	17/32	50.6
	02E B 615	210400	300000	18610	1120	13.000	5.512	3.280	3.280	11.57	7/16	1	99.0
	03 B 615	279200	383100	20010	1030	14.750	7.008	3.626	4.283	12.83	19/32	5/8	174
7	01E B 700	125100	190000	11730	1220	11.250	4.291	2.185	2.185	10.24	15/16	17/32	50.6
	02E B 700	210400	300000	18610	1120	13.000	5.512	3.280	3.280	11.57	7/16	1	99.0
	03 B 700	279200	383100	20010	1030	14.750	7.008	3.626	4.283	12.83	19/32	5/8	174
7 15/16	01E B 715	152600	242300	16310	1070	12.250	4.291	2.374	2.374	11.22	15/16	11/16	55.0
	02E B 715	255500	365700	27350	960	14.500	6.142	3.563	3.563	12.91	1/2	1	130
	03 B 715	326200	434500	22390	880	16.500	7.520	3.846	4.657	14.41	5/8	5/8	231

CARTRIDGE

Cartridge Only	References (1)	Principal Dimensions			Mass (lb)
		G (in)	J (in)	L (in)	
01 C 11	01E BC 607 AT	12 1/4	3	7 9/16	66
02 C 32	02E BC 607 AT	14 1/2	3 3/4	9 1/8	123
03 C 59	03 BC 607 AT	16 5/8	4 3/4	10 9/16	178
01 C 11	01E BC 608 AT	12 1/4	3	7 9/16	66
02 C 32	02E BC 608 AT	14 1/2	3 3/4	9 1/8	123
03 C 59	03 BC 608 AT	16 5/8	4 3/4	10 9/16	178
01 C 12	01E BC 615 AT	12 3/4	2 3/4	7 7/8	68.2
02 C 33	02E BC 615 AT	15	3 3/4	9 1/2	145
03 C 60	03 BC 615 AT	17	5 1/4	11 3/16	191
01 C 12	01E BC 700 AT	12 3/4	2 3/4	7 7/8	68.2
02 C 33	02E BC 700 AT	15	3 3/4	9 1/2	145
03 C 60	03 BC 700 AT	17	5 1/4	11 3/16	191
01 C 13	01E BC 715 AT	14 1/8	3 3/8	7 7/8	90.2
02 C 34	02E BC 715 AT	16 3/4	4 1/8	10 3/16	185
03 C 61	03 BC 715 AT	19 1/4	5 3/4	11 3/16	240

1) Add 'EX' or 'GR' to reference for expansion type or fixed type respectively, eg:
 bearing: 01E B 607 EX
 cartridge: 01E C 11 EX
 bearing, cartridge and seals: 01E BC 607 EX AT
 complete unit: 01E BCP 607 EX AT
 Pillow blocks are common between expansion and fixed typed units.

2) Total available axial movement given. Maximum offset from centerline half this amount. 'Usual' axial movement denotes maximum recommended range of running positions of EX bearing for optimum performance. 'Maximum' axial movement denotes available movement before bearing strikes inside of standard Cooper cartridge.

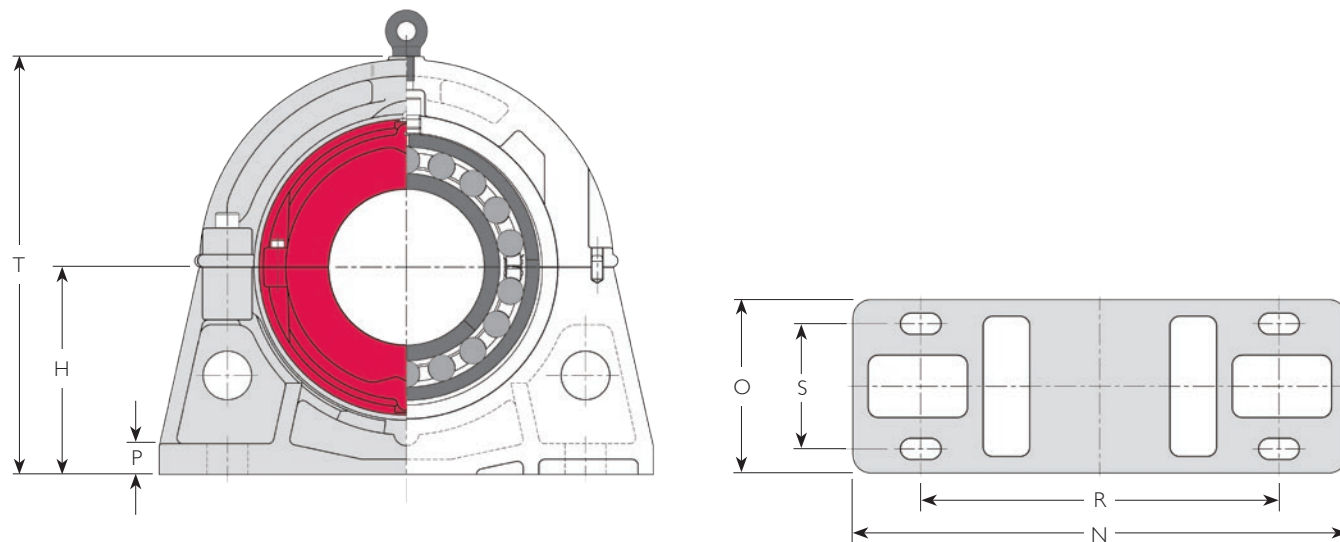

PILLOW BLOCK

References (I)		R					Bolts				Mass (lb)		Shaft Diameter d (in)		
Pillow Block Only	Complete Unit	H (in)	Min. (in)	Max. (in)	Ro (in)	S (in)	No.	Metric Size	Inch Size	N (in)	O (in)	P (in)		T (in)	Pillow Block Only
P11	01E BCP 607 AT	8 3/8	14	15	-	4 1/2	4	M24	1"	20	7	1 1/4	16 15/16	117	229
P32	02E BCP 607 AT	10 1/2	16 7/8	18 3/8	-	6 3/4	4	M30	1 1/4"	23 1/2	9 1/2	1 3/4	21 1/16	233	442
P59	03 BCP 607 AT	10 1/2	24	25 1/2	-	5 1/2	4	M30	1 1/4"	29	9	2 3/8	22 7/16	356	693
P11	01E BCP 608 AT	8 3/8	14	25	-	4 1/2	4	M24	1"	20	7	1 1/4	16 15/16	117	229
P32	02E BCP 608 AT	10 1/2	16 7/8	18 3/8	-	6 3/4	4	M30	1 1/4"	23 1/2	9 1/2	1 3/4	21 1/16	233	442
P59	03 BCP 608 AT	10 1/2	24	25 1/2	-	5 1/2	4	M30	1 1/4"	29	9	2 3/8	22 7/16	356	693
P12	01E BCP 615 AT	9 1/4	14 3/4	15 3/4	-	5	4	M24	1"	21	7 1/2	1 3/8	18 1/2	139	257
P33	02E BCP 615 AT	10 3/4	17 1/4	18 3/4	-	6 1/2	4	M30	1 1/4"	25	9 1/2	1 3/4	21 7/16	255	499
P60	03 BCP 615 AT	11	24 1/4	25 3/4	-	6	4	M30	1 1/4"	30	10	2 1/2	22 13/16	378	744
P12	01E BCP 700 AT	9 1/4	14 3/4	15 3/4	-	5 1/16	4	M24	1"	21	7 1/2	1 3/8	18 1/2	139	257
P33	02E BCP 700 AT	10 3/4	17 1/4	18 3/4	-	6 9/16	4	M30	1 1/4"	25	9 1/2	1 3/4	21 7/16	255	499
P60	03 BCP 700 AT	11	24 1/4	25 3/4	-	6	4	M30	1 1/4"	30	10	2 1/2	22 3/4	378	744
P13	01E BCP 715 AT	9 3/4	16 1/8	17 1/8	-	5 1/2	4	M24	1"	22 1/2	8	1 1/2	19 1/2	183	328
P34	02E BCP 715 AT	12	19 1/4	20 3/4	-	7 1/2	4	M30	1 1/4"	27	10 1/2	2	24	319	634
P61	03 BCP 715 AT	12 1/4	24 1/4	25 3/4	-	6 3/4	4	M36	1 1/2"	33	10 1/2	2 5/8	25 3/4	491	961

3) Maximum fillet radii of abutments:
 inner race: 3/32"
 outer race: 5/64"

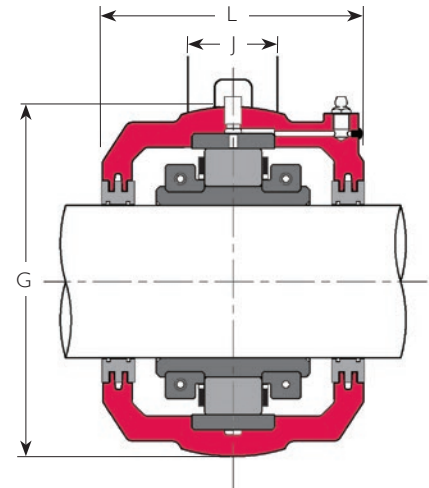
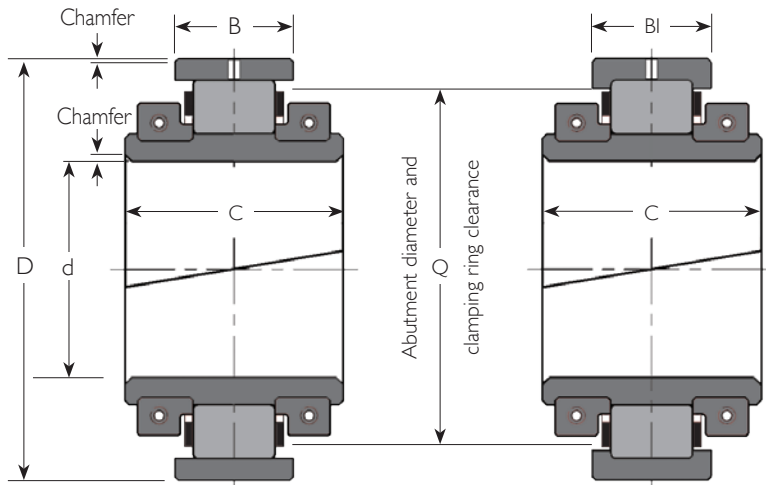

ROLLER BEARING

Shaft Dia. d (in)	Reference (1)	Bearing Ratings				Principal Dimensions					Axial Movement (2)		
		Cr (lb)	Cor (lb)	Ca (lb)	Max. Speed (rpm)	D (in)	C (in)	B (in)	BI (in)	Q (in)	Usual (in)	Max. (in)	Mass (lb)
8	01E B 800	152600	242300	16310	1070	12.250	4.291	2.374	2.374	11.22	5/16	11/16	55.0
	02E B 800	255500	365700	27350	960	14.500	6.142	3.563	3.563	12.91	1/2	1	130
	03 B 800	326200	434500	22390	880	16.500	7.520	3.846	4.657	14.41	5/8	5/8	231
9	01E B 900	160600	267800	17950	930	13.500	4.528	2.500	2.500	12.40	5/16	3/4	70.4
	02E B 900	277300	418800	31120	850	15.500	6.417	3.563	3.563	13.94	1/2	1	150
	03 B 900	356500	486200	24590	760	18.500	8.346	4.315	5.189	16.14	11/16	11/16	319
10	01E B 1000	180700	307400	21730	820	14.750	4.803	2.626	2.626	13.54	3/8	7/8	88.0
	02E B 1000	302600	446400	37650	750	17.000	6.693	3.811	3.811	15.28	1/2	1 1/8	169
	03 B 1000	399700	573500	29450	700	19.000	8.307	4.157	4.906	16.93	11/16	1 5/16	330
11	01E B 1100	206100	350700	28500	730	16.000	5.039	2.717	2.717	14.76	3/8	25/32	110
	02E B 1100	347300	547500	42730	670	18.250	7.323	4.000	4.000	16.54	9/16	1 1/8	189
	03X B 1100	439700	665400	34390	620	20.500	9.094	5.189	5.189	18.19	11/16	1 9/16	433
	03E B 1100	473200	726800	34390	620	19.500	9.606	5.500	5.500	17.80	25/32	1 5/16	400
12	01E B 1200	234000	423900	31150	650	17.250	5.630	2.937	2.937	15.91	3/8	1	132
	02E B 1200	373100	614900	48020	610	19.500	7.598	4.063	4.063	17.64	9/16	1 3/16	271
	03 B 1200	484700	744500	39120	560	22.000	9.606	5.500	5.500	19.53	3/4	1 11/16	524

CARTRIDGE

References (1)	Principal Dimensions				Mass (lb)
	Cartridge Only	Cartridge, Bearing and Seals	G (in)	J (in)	
01 C 13	01E BC 800 AT	14 1/8	3 3/8	7 7/8	90.2
02 C 34	02E BC 800 AT	16 3/4	4 1/8	10 3/16	185
03 C 61	03 BC 800 AT	19 1/4	5 3/4	11 3/16	240
01 C 14	01E BC 900 AT	15 1/4	3 1/4	8 1/2	101
02 C 35	02E BC 900 AT	18	4 1/4	10 3/4	216
03 C 62	03 BC 900 AT	21 1/2	6 1/2	13 1/8	341
01 C 15	01E BC 1000 AT	16 1/2	3 1/2	8 3/4	128
02 C 36	02E BC 1000 AT	19 1/2	4 5/8	11	231
03 C 63	03 BC 1000 AT	22	6 1/2	13 1/8	354
01 C 16	01E BC 1100 AT	17 7/8	3 3/4	9 1/8	154
02 C 37	02E BC 1100 AT	20 3/4	5 1/8	11 13/16	288
03X C 64	03X BC 1100 AT	23 1/2	6 1/2	13 7/8	440
03E C 83	03E BC 1100 AT	22 1/2	6 1/2	14	449
01 C 17	01E BC 1200 AT	19 1/4	3 7/8	9 3/4	189
02 C 38	02E BC 1200 AT	21 3/4	5	12	284
03 C 65	03 BC 1200 AT	25 1/4	6 1/2	14 9/16	526

1) Add 'EX' or 'GR' to reference for expansion type or fixed type respectively, eg:
 bearing: 01E B 800 EX
 cartridge: 01 C 13 EX
 bearing, cartridge and seals: 01E BC 800 EX AT
 complete unit: 01E BCP 800 EX AT
 Pillow blocks are common between expansion and fixed typed units.

2) Total available axial movement given. Maximum offset from centerline half this amount. 'Usual' axial movement denotes maximum recommended range of running positions of EX bearing for optimum performance. 'Maximum' axial movement denotes available movement before bearing strikes inside of standard Cooper cartridge.

4 BOLT

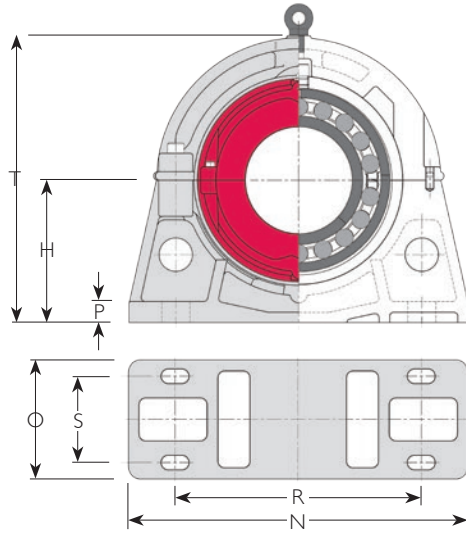

8 BOLT

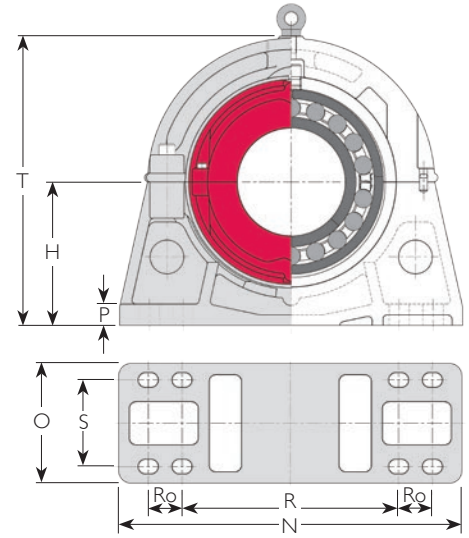

PILLOW BLOCK

References (I)		R					Bolts					Mass (lb)		Shaft Diameter d (in)	
Pillow Block Only	Complete Unit	H (in)	Min. (in)	Max. (in)	Ro (in)	S (in)	No.	Metric Size	Inch Size	N (in)	O (in)	P (in)	T (in)		Pillow Block Only
P13	01E BCP 800 AT	9 3/4	16 1/8	17 1/8	-	5 1/2	4	M24	1"	22 1/2	8	1 1/2	19 1/2	183	328
P34	02E BCP 800 AT	12	19 1/4	20 3/4	-	7 1/2	4	M30	1 1/4"	27	10 1/2	2	24	319	634
P61	03 BCP 800 AT	12 1/4	24 1/4	25 3/4	-	6 3/4	4	M36	1 1/2"	33	10 1/2	2 5/8	25 3/4	491	961
P14	01E BCP 900 AT	10 5/8	17 3/8	18 7/8	-	5 1/2	4	M30	1 1/4"	25	8 1/2	1 5/8	21 1/4	198	370
P35	02E BCP 900 AT	12 3/4	20 7/8	22 3/8	-	7 1/2	4	M36	1 1/2"	29 1/2	11	2	25 9/16	394	759
P62	03 BCP 900 AT	13 3/4	28 1/4	29 3/4	-	7	4	M42	1 3/4"	37 1/2	11	3	28 3/4	680	1340
P15	01E BCP 1000 AT	11 1/2	19	20 1/2	-	5 1/2	4	M30	1 1/4"	27	9	1 3/4	23	251	466
P36	02E BCP 1000 AT	14	22 3/4	24 1/4	-	8	4	M36	1 1/2"	32	11 1/2	2 1/8	28	466	867
P63	03 BCP 1000 AT	15 1/2	25 5/8	27 1/8	-	12	4	M42	1 3/4"	36	16	3	31	862	1547
P16	01E BCP 1100 AT	12 1/4	20 1/4	21 3/4	-	5 1/2	4	M30	1 1/4"	28 1/2	9	1 7/8	24 7/16	312	576
P37	02E BCP 1100 AT	14 7/8	20 1/4	21 3/4	4	10	8	M30	1 1/4"	36	13	2 3/8	29 15/16	642	1120
P64	03X BCP 1100 AT	16 3/4	23 1/4	24 3/4	4	12 1/2	8	M36	1 1/2"	40 1/2	16	3	33 1/2	1089	1962
P83	03E BCP 1100 AT	14 1/2	19	20 1/2	4 3/4	7	8	M36	1 1/2"	37	11	2 3/4	30 7/8	451	1300
P17	01E BCP 1200 AT	13 1/2	22 3/16	23 3/4	-	7	4	M30	1 1/4"	30	10	2	26 15/16	372	693
P38	02E BCP 1200 AT	15 1/2	21 1/2	23 1/16	4	10	8	M30	1 1/4"	37 11/16	13	2 3/8	31 1/8	726	1280
P65	03 BCP 1200 AT	18	25 3/4	27 5/16	4	13	8	M36	1 1/2"	43	16 9/16	3	36	1289	2339

3) Maximum fillet radii of abutments:
 inner race: 3/32"
 outer race: 5/64"

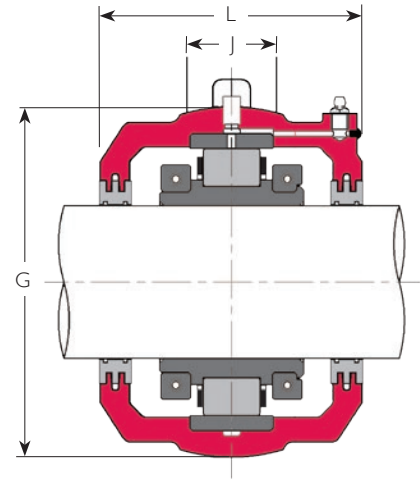
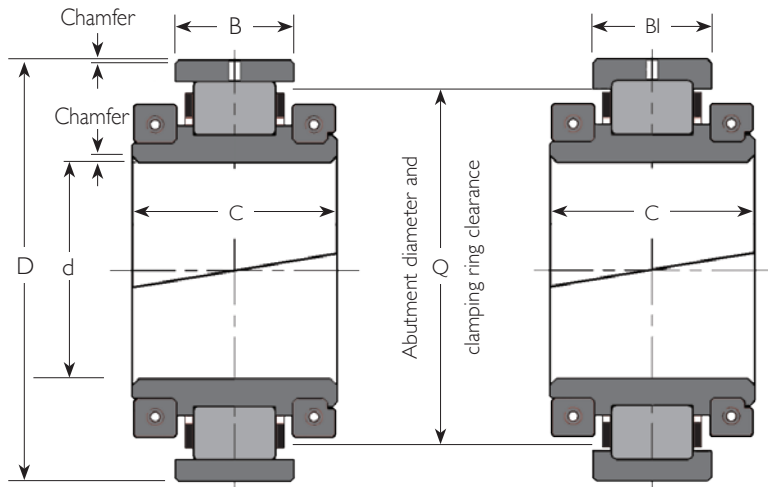

ROLLER BEARING

Shaft Dia. d (in)	Reference (1)	Bearing Ratings				Principal Dimensions					Axial Movement (2)		
		Cr (lb)	Cor (lb)	Ca (lb)	Max. Speed (rpm)	D (in)	C (in)	B (in)	BI (in)	Q (in)	Usual (in)	Max. (in)	Mass (lb)
13	01 B 1300	201000	368200	20010	590	18.250	5.354	2.937	2.937	17.01	3/8	7/8	158
	02 B 1300	352900	589400	32370	550	20.750	7.559	4.189	4.189	18.82	1 3/16	330	
	03 B 1300	568500	853100	44740	500	24.500	10.709	6.315	6.315	21.65	7/8	1 7/8	719
14	01 B 1400	210200	398800	22390	540	19.250	5.354	2.937	2.937	17.95	3/8	7/8	172
	02 B 1400	392100	660900	35740	500	22.250	7.874	4.563	4.563	20.24	5/8	1 3/8	400
	03E B 1400	618200	987300	48110	460	24.250	10.984	6.220	6.220	21.89	7/8	1 3/4	700
15	01 B 1500	225900	432700	24370	500	20.500	5.512	3.000	3.000	19.13	3/8	7/8	189
	02 B 1500	418600	731500	39120	460	23.000	7.874	4.374	4.374	21.10	5/8	1 3/16	409
	03 B 1500	678700	1079000	56420	420	27.000	11.496	6.563	6.563	24.02	7/8	1 15/16	948
16	01 B 1600	235600	465600	26080	460	21.500	5.512	3.000	3.000	20.16	3/8	7/8	209
	02 B 1600	437900	772900	42260	430	24.250	7.874	4.563	4.563	22.28	5/8	1 15/16	460
17	01 B 1700	244800	498600	27200	430	22.500	5.512	3.000	3.000	21.18	3/8	7/8	229
	02 B 1700	465100	832200	45410	400	25.500	7.874	4.689	4.689	23.46	11/16	1 15/16	530
	03E B 1700	781000	135000	62040	360	27.559	11.181	6.299	6.299	25.20	7/8	1 5/8	869
18	01 B 1800	253800	531900	28550	410	23.500	5.512	3.000	3.000	22.13	3/8	7/8	251
	02 B 1800	493400	912000	48560	380	26.250	7.874	4.563	4.563	24.33	11/16	1 3/16	550
	03E B 1800	820500	1384000	67890	340	29.134	11.575	6.693	6.693	26.77	15/16	1 13/16	948

CARTRIDGE

Cartridge Only	References (1)	Principal Dimensions			Mass (lb)
		G (in)	J (in)	L (in)	
01 C 18	01 BC 1300 AT	20 1/2	3 3/4	10 11/16	233
02 C 39	02 BC 1300 AT	23 1/8	5	13	378
03 C 66	03 BC 1300 AT	28 1/4	6 3/4	16 1/2	601
01 C 19	01 BC 1400 AT	21 1/2	3 7/8	10 11/16	257
02 C 40	02 BC 1400 AT	24 3/4	5 3/4	13 1/2	409
03E C 86	03E BC 1400 AT	27 3/4	7 3/4	17	847
01 C 20	01 BC 1500 AT	22 1/2	3 7/8	11	277
02 C 41	02 BC 1500 AT	25 1/2	5 3/4	13 1/2	460
03 C 68	03 BC 1500 AT	30 1/2	8	17 1/4	878
01 C 21	01 BC 1600 AT	23 3/4	4	11 1/4	310
02 C 42	02 BC 1600 AT	27	5 3/4	13 3/4	559
01 C 22	01 BC 1700 AT	24 3/4	4	11 3/4	330
02 C 43	02 BC 1700 AT	28 1/4	5 3/4	14	581
03E C 89	03E BC 1700 AT	31.024	7 7/8	17 7/16	989
01 C 23	01 BC 1800 AT	25 5/8	4 1/4	12 3/16	332
02 C 44	02 BC 1800 AT	28 7/8	5 3/4	14	583
03E C 90	03E BC 1800 AT	33.071	7 7/8	17 11/16	999

1) Add 'EX' or 'GR' to reference for expansion type or fixed type respectively, eg:
 bearing: 01 B 1300 EX
 cartridge: 01 C 18 EX
 bearing, cartridge and seals: 01 BC 1300 EX AT
 complete unit: 01 BCP 1300 EX AT
 Pillow blocks are common between expansion and fixed typed units.

2) Total available axial movement given. Maximum offset from centerline half this amount. 'Usual' axial movement denotes maximum recommended range of running positions of EX bearing for optimum performance. 'Maximum' axial movement denotes available movement before bearing strikes inside of standard Cooper cartridge.

4 BOLT

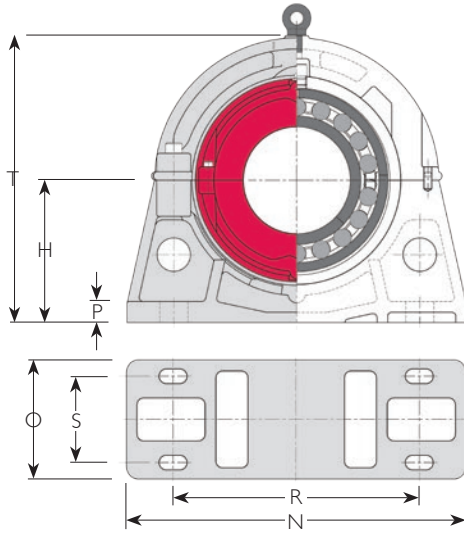

8 BOLT

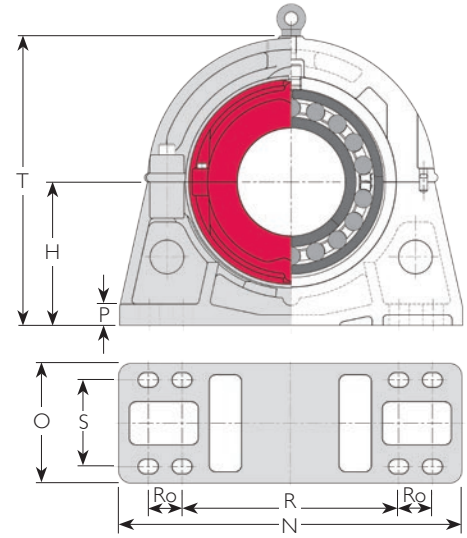

PILLOW BLOCK

References (I)		R						Bolts					Mass (lb)		Shaft Diameter d (in)
Pillow Block Only	Complete Unit	H (in)	Min. (in)	Max. (in)	Ro (in)	S (in)	No.	Metric Size	Inch Size	N (in)	O (in)	P (in)	T (in)	Pillow Block Only	
P18	01 BCP 1300 AT	14 1/2	23 11/16	25 1/4	-	7	4	M36	1 1/2"	31 15/16	10	2 1/8	28 15/16	431	823
P39	02 BCP 1300 AT	16 1/2	23 1/4	24 13/16	4	8 1/4	8	M30	1 1/4"	40	11 1/2	2 1/2	33 7/16	843	1551
P66	03 BCP 1300 AT	20 13/32	29 3/16	30 13/16	4 1/4	10 1/2	8	M36	1 1/2"	47	14	3 1/8	40 3/4	1441	2761
P19	01 BCP 1400 AT	15 1/4	24 15/16	26 1/2	-	6 1/2	4	M36	1 1/2"	33 7/16	10	2 1/4	30 1/2	469	898
P40	02 BCP 1400 AT	17 3/4	25 3/16	26 3/4	4	11	8	M36	1 1/2"	43	14 1/2	2 5/8	35 7/16	944	1753
P86	03E BCP 1400 AT	18 1/2	24 15/16	27	5 1/4	7 1/2	8	M42	1 3/4"	48 1/16	12 1/2	3 1/4	39 3/8	1021	2567
P20	01 BCP 1500 AT	15 5/8	25 13/16	27 3/8	-	6 9/16	4	M36	1 1/2"	35 1/2	10	2 3/8	31 5/16	634	1100
P41	02 BCP 1500 AT	18 1/4	26 1/16	27 5/8	4	11	8	M36	1 1/2"	43	14 1/2	2 5/8	36 7/16	979	1848
P68	03 BCP 1500 AT	22	30 11/16	32 3/4	4 1/2	11 1/2	8	M42	1 3/4"	50	15 1/2	3 5/8	44 1/8	1890	3716
P21	01 BCP 1600 AT	17	27 11/16	29 5/16	-	6 9/16	4	M36	1 1/2"	37	10	2 5/8	34 1/16	680	1199
P42	02 BCP 1600 AT	19 1/2	27 15/16	29 1/2	4	11	8	M36	1 1/2"	46	14 1/2	2 3/4	39	1181	2200
P22	01 BCP 1700 AT	17 1/2	29	30 9/16	-	6 9/16	4	M36	1 1/2"	38 1/16	10	2 5/8	35 1/16	695	1254
P43	02 BCP 1700 AT	20 1/4	29 7/16	31	4	11	8	M36	1 1/2"	47	14 1/2	2 3/4	40 9/16	1241	2352
P89	03E BCP 1700 AT	20	26 1/8	28 3/16	5 7/8	8 1/4	8	M48	2"	50	14 3/16	3 9/16	42 5/16	1060	2827
P23	01 BCP 1800 AT	18 1/4	30 1/4	31 13/16	-	7 1/2	4	M42	1 3/4"	41	11	2 3/4	36 7/16	814	1397
P44	02 BCP 1800 AT	21	30 1/4	31 13/16	4 1/8	11	8	M36	1 1/2"	49	14 1/2	2 7/8	42 1/8	1241	2374
P90	03E BCP 1800 AT	21 5/8	29 11/16	31 3/4	5 7/8	8 11/16	8	M48	2"	53 15/16	15	3 3/4	45 7/8	1551	3498

3) Maximum fillet radii of abutments:
 inner race: 0.09"
 outer race: 0.08"

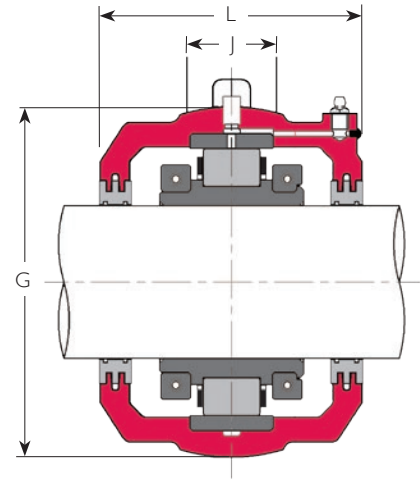
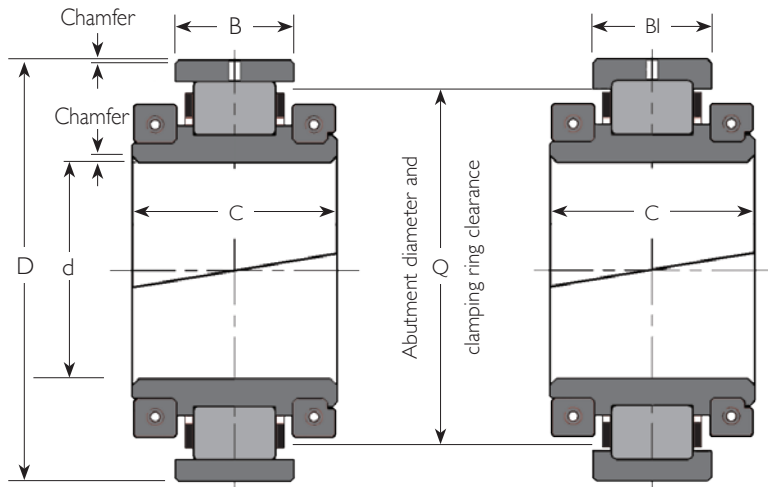

ROLLER BEARING

Shaft Dia. d (in)	Reference (1)	Bearing Ratings				Principal Dimensions					Axial Movement (2)		
		Cr (lb)	Cor (lb)	Ca (lb)	Max. Speed (rpm)	D (in)	C (in)	B (in)	BI (in)	Q (in)	Usual (in)	Max. (in)	Mass (lb)
19	01 B 1900	262800	546900	29900	380	24.750	5.669	3.189	3.189	23.39	7/16	15/16	282
	02 B 1900	520000	993400	51700	360	27.500	8.780	4.689	4.689	25.51	11/16	1 5/16	579
20	01 B 2000	272300	582900	31020	360	25.750	6.614	3.157	3.157	24.33	7/16	7/8	299
	02 B 2000	546300	1074000	54850	340	28.250	8.898	4.563	4.563	26.38	11/16	1 3/16	598
	03 B 2000	918800	1583000	78010	310	33.500	11.811	7.378	7.378	30.12	1 2 3/16	1 606	
21	01 B 2100	281700	619300	31700	340	27.250	6.614	3.189	3.189	25.59	7/16	7/8	361
	02 B 2100	597500	1155000	58000	330	30.000	9.016	4.689	4.689	27.95	11/16	1 1/16	680
22	01 B 2200	290900	655500	31920	330	28.250	6.614	3.189	3.189	26.57	7/16	7/8	392
	02 B 2200	627200	1249000	61150	310	31.250	9.173	4.811	4.811	29.06	11/16	1 3/16	739
	03E B 2200	1050000	1913000	86100	280	34.000	12.205	7.752	7.752	31.50	1 1/8	2 3/16	1397
23	01 B 2300	311800	705400	32370	310	29.500	6.772	3.311	3.311	27.80	7/16	1	429
	02 B 2300	525100	1087000	51030	300	32.000	9.134	4.689	4.689	29.69	5/8	1 7/16	748
	03E B 2300	1099000	1913000	89920	270	35.039	12.205	7.244	7.244	32.52	1 1/16	1 7/8	1496
24	01 B 2400	321700	744300	33050	300	30.500	6.772	3.311	3.311	28.82	7/16	1	462
	02 B 2400	653000	1347000	67440	290	33.000	8.425	4.689	4.689	30.94	11/16	1 1/16	838

CARTRIDGE

Cartridge Only	References (1)	Principal Dimensions			Mass (lb)
		Cartridge, Bearing and Seals	G (in)	J (in)	
01 C 24	01 BC 1900 AT	26 7/8	4 1/4	12 3/4	356
02 C 45	02 BC 1900 AT	30	5 3/4	14 3/4	598
01 C 25	01 BC 2000 AT	28 1/4	4 1/2	13	422
02 C 46	02 BC 2000 AT	31	5 3/4	14 3/4	711
03 C 94	03 BC 2000 AT	37 3/4	8	20	1694
01 C 26	01 BC 2100 AT	29 3/4	4 1/2	13 1/4	497
02 C 47	02 BC 2100 AT	32 3/4	5 7/8	14 3/4	772
01 C 27	01 BC 2200 AT	30 3/4	4 1/2	13 1/2	554
02 C 48	02 BC 2200 AT	34 1/8	6	15	834
03E C 94	03E BC 2200 AT	37 3/4	8	19 5/16	1476
01 C 28	01 BC 2300 AT	32 1/8	4 3/4	13 3/4	601
02 C 49	02 BC 2300 AT	34 3/4	6	15	849
03E C 95	03E BC 2300 AT	38.976	8	19 5/16	1584
01 C 29	01 BC 2400 AT	33 1/8	4 3/4	13 3/4	638
02 C 50	02 BC 2400 AT	36	6	15 1/2	999

1) Add 'EX' or 'GR' to reference for expansion type or fixed type respectively, eg:
 bearing: 01 B 1900 EX
 cartridge: 01 C 24 EX
 bearing, cartridge and seals: 01 BC 1900 EX AT
 complete unit: 01 BCP 1900 EX AT
 Pillow blocks are common between expansion and fixed typed units.

2) Total available axial movement given. Maximum offset from centerline half this amount. 'Usual' axial movement denotes maximum recommended range of running positions of EX bearing for optimum performance. 'Maximum' axial movement denotes available movement before bearing strikes inside of standard Cooper cartridge.

4 BOLT

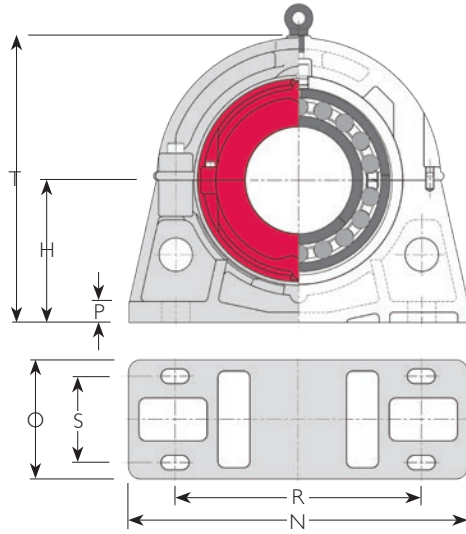

8 BOLT

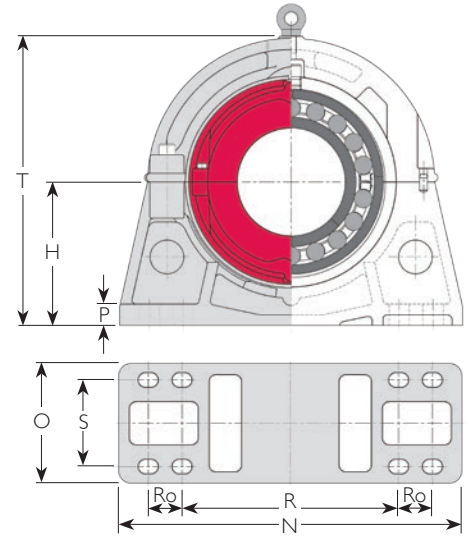

PILLOW BLOCK

References (1)		R					Bolts					Mass (lb)		Shaft Diameter d (in)	
Pillow Block Only	Complete Unit	H (in)	Min. (in)	Max. (in)	Ro (in)	S (in)	No.	Metric Size	Inch Size	N (in)	O (in)	P (in)	T (in)		Pillow Block Only
P24	01 BCP 1900 AT	19	31 5/16	32 15/16	-	7 3/8	4	M42	1 3/4"	43	12	2 7/8	38	884	1522
P45	02 BCP 1900 AT	21 3/4	31 3/16	32 3/4	4 1/2	11	8	M36	1 1/2"	50	14 1/2	3	43 11/16	1518	2695
P25	01 BCP 2000 AT	19 1/4	32 7/16	34	-	8 1/2	4	M42	1 3/4"	43	12	3	38 9/16	884	1606
P46	02 BCP 2000 AT	22 1/2	32 7/16	34	4 1/2	11	8	M36	1 1/2"	51	14 1/2	3 1/8	45 1/16	1489	2798
P94	03 BCP 2000 AT	24 1/2	36	38 1/16	6 1/2	9 1/2	8	M56	2 1/4"	63	16	4	52 3/4	2200	5500
P26	01 BCP 2100 AT	21	34 13/16	36 3/8	-	8 1/2	4	M42	1 3/4"	47	12	3 1/8	41 15/16	1089	1947
P47	02 BCP 2100 AT	23 1/4	34 1/4	35 13/16	4 1/2	11	8	M36	1 1/2"	55 1/16	14 1/2	3 1/4	46 7/16	1991	3443
P27	01 BCP 2200 AT	23 1/4	36 1/16	37 5/8	-	8 1/8	4	M42	1 3/4"	48 1/16	12	3 1/4	43 11/16	1254	2200
P48	02 BCP 2200 AT	24 1/4	35 9/16	37 5/8	4 1/2	11	8	M42	1 3/4"	56	15	3 3/8	48 7/16	2123	3696
P94	03E BCP 2200 AT	24 1/2	36	38 1/16	6 1/2	9 1/2	8	M36	2 1/4"	63	16	4	52 3/4	2200	5073
P28	01 BCP 2300 AT	22 3/4	33 3/4	35 1/4	4	8 11/16	8	M36	1 1/2"	53	12	3 9/16	45 1/2	1386	2416
P49	02 BCP 2300 AT	25	36 11/16	38 3/4	4 1/2	11	8	M42	1 3/4"	57	15	3 9/16	50	2200	3797
P95	03E BCP 2300 AT	24 1/2	36	38 1/16	6 1/2	9 1/2	8	M56	2 1/4"	63	16	4	52 3/4	2046	5126
P29	01 BCP 2400 AT	23 1/2	34 15/16	36 9/16	4 1/8	8 11/16	8	M36	1 1/2"	54	12	3 9/16	47 1/4	1386	2486
P50	02 BCP 2400 AT	26 1/2	38 3/4	40 13/16	4 1/2	11	8	M42	1 3/4"	60	15	3 5/8	52 15/16	2310	4147

3) Maximum fillet radii of abutments:
 inner race: 3/32"
 outer race: 5/64"

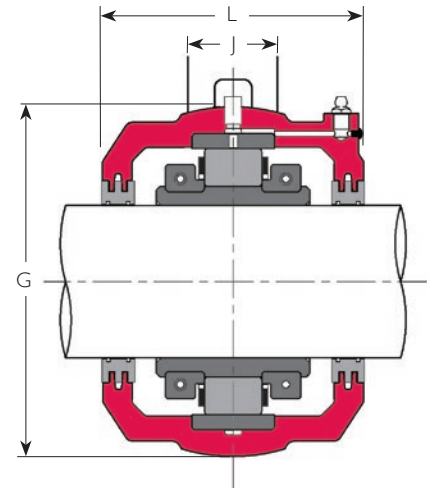
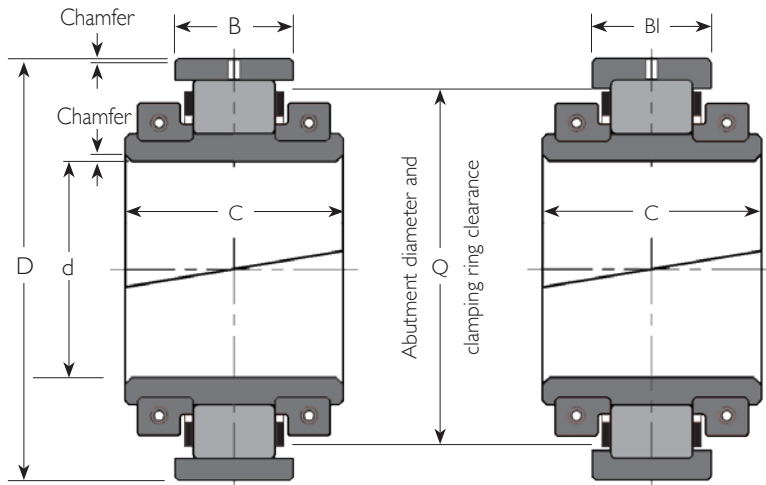

ROLLER BEARING

Shaft Dia. d (mm)	Reference (1)	Equivalent Inch-size Bearing (4)	Bearing Ratings				Principal Dimensions					Axial Movement (2)		
			Cr (kN)	Cor (kN)	Ca (kN)	Max. Speed (rpm)	D (mm)	C (mm)	B (mm)	BI (mm)	Q (mm)	Usual (mm)	Max. (mm)	Mass (kg)
35	01 B 35M	01 B 108	67	67	3.2	5400	84.14	50.1	23.8	23.8	75	3.5	5.5	1.2
40	01 B 40M	01 B 108	67	67	3.2	5400	84.14	50.1	23.8	23.8	75	3.5	5.5	1.2
45	01E B 45M	01E B 200	95	105	3.8	4630	98.42	55.7	25.4	25.4	90	4	5	1.5
50	01E B 50M	01E B 200	95	105	3.8	4630	98.42	55.7	25.4	25.4	90	4	5	1.5
	02 B 50M	02 B 200	119	125	6.2	4350	107.95	67.5	35.0	35.0	98	5	10.5	2.0
55	01E B 55M	01E B 208	135	157	7.2	3940	114.30	55.7	27.0	27.0	105	4.5	4.5	1.8
60	01E B 60M	01E B 208	135	157	7.2	3940	114.30	55.7	27.0	27.0	105	4.5	4.5	1.8
	02 B 60M	02 B 208	168	193	8.8	3680	127.00	72.3	38.9	38.9	116	5.5	11	3.0
65	01E B 65M	01E B 208	135	157	7.2	3940	114.30	55.7	27.0	27.0	105	4.5	4.5	1.8
	02 B 65M	02 B 208	168	193	8.8	3680	127.00	72.3	38.9	38.9	116	5.5	11	3.0
70	01E B 70M	01E B 300	166	197	10.8	3310	133.35	61.2	31.8	31.8	124	5	7	2.5
	02 B 70M	02 B 300	229	268	10.6	3080	149.22	82.6	46.1	46.1	138	6	13.5	5.0
75	100 B 75M	100 B 300	91	128	7.0	4125	114.30	48.0	27.0	27.0	102	3.5	7	1.2
	01E B 75M	01E B 300	166	197	10.8	3310	133.35	61.2	31.8	31.8	124	5	7	2.5
	02 B 75M	02 B 300	229	268	10.6	3080	149.22	82.6	46.1	46.1	138	6	13.5	5.0

CARTRIDGE

References (1)		Principal Dimensions			
Cartridge Only	Cartridge, Bearing and Seals	G (mm)	J (mm)	L (mm)	Mass (kg)
01 C 01	01 BC 35M AT	100.00	25	86	2
01 C 01	01 BC 40M AT	100.00	25	86	2
01 C 02	01E BC 45M AT	117.48	25	98	2.5
01 C 02	01E BC 50M AT	117.48	25	98	2.5
01 C 03	02 BC 50M AT	134.94	32	114	4.0
01 C 03	01E BC 55M AT	134.94	32	104	3.2
01 C 03	01E BC 60M AT	134.94	32	104	3.2
02 C 04	02 BC 60M AT	157.16	38	126	7.0
01 C 03	01E BC 65M AT	134.94	32	104	3.2
02 C 04	02 BC 65M AT	157.16	38	126	7.0
01 C 04	01E BC 70M AT	157.16	38	114	5.5
02 C 05	02 BC 70M AT	177.80	50	140	9.0
100 C 03	100 BC 75M AT	134.94	32	104	3.6
01 C 04	01E BC 75M AT	157.16	38	114	5.5
02 C 045	02 BC 75M AT	177.80	50	140	9.0

1) Add 'EX' or 'GR' to reference for expansion type or fixed type respectively, eg:
 bearing: 01E B 60 EX
 cartridge: 01 C 03 EX
 bearing, cartridge and seals: 01E BC 60M EX AT
 complete unit: 01E BCP 60M EX AT
 Pillow blocks are common between expansion and fixed typed units.

2) Total available axial movement given. Maximum offset from centerline half this amount. 'Usual' axial movement denotes maximum recommended range of running positions of EX bearing for optimum performance. 'Maximum' axial movement denotes available movement before bearing strikes inside of standard Cooper cartridge.

2 BOLT

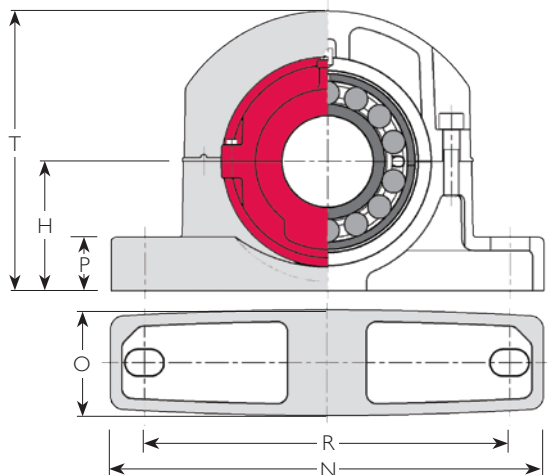

4 BOLT

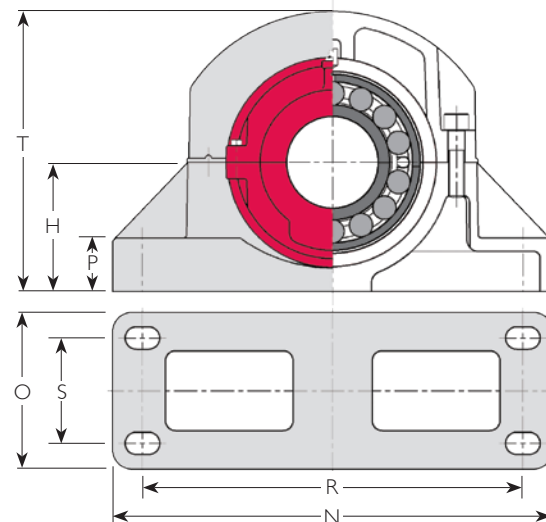

PILLOW BLOCK

References (I)		H (mm)	R		Ro (mm)	S (mm)	Bolts				Mass (kg)				Shaft Diameter d (mm)	
Pillow Block Only	Complete Unit		Min. (mm)	Max. (mm)			No.	Metric Size	Inch Size	N (mm)	O (mm)	P (mm)	T (mm)	Pillow Block Only (kg)		Complete Unit (kg)
P01	01 BCP 35M AT	60	172	192	-	-	2	M12	1/2"	228	60	22	138	2.5	5.7	35
P01	01 BCP 40M AT	60	172	192	-	-	2	M12	1/2"	228	60	22	138	2.5	5.7	40
P02	01E BCP 45M AT	70	203	227	-	-	2	M16	5/8"	270	60	25	158	3.2	7.2	45
P02	01E BCP 50M AT	70	203	227	-	-	2	M16	5/8"	270	60	25	158	3.2	7.2	50
P03	02 BCP 50M AT	80	226	242	-	-	2	M16	5/8"	280	70	32	180	4.9	10.9	
P03	01E BCP 55M AT	80	226	242	-	-	2	M16	5/8"	280	70	32	180	4.9	9.9	55
P03	01E BCP 60M AT	80	226	242	-	-	2	M16	5/8"	280	70	32	180	4.9	9.9	60
P04	02 BCP 60M AT	95	260	280	-	-	2	M20	3/4"	330	76	38	208	6.9	16.9	
P03	01E BCP 65M AT	80	226	242	-	-	2	M16	5/8"	280	70	32	180	4.9	9.9	65
P04	02 BCP 65M AT	95	260	280	-	-	2	M20	3/4"	330	76	38	208	6.9	16.9	
P04	01E BCP 70M AT	95	260	280	-	-	2	M20	3/4"	330	76	38	208	6.9	14.9	70
P0510	02 BC4P 70M AT	112	316	340	-	88	4	M20	3/4"	380	140	44	252	15.3	29.3	
P03	100 BCP 75M AT	80	226	242	-	-	2	M16	5/8"	280	70	32	180	4.9	9.7	75
P04	01E BCP 75M AT	95	260	280	-	-	4	M20	3/4"	330	76	38	208	6.9	14.9	
P0510	02 BC4P 75M AT	112	316	340	-	88	4	M20	3/4"	380	140	44	252	15.3	29.3	

3) Maximum fillet radii of abutments:
 inner race: 1.2mm
 outer race: 0.4mm

4) Refer to data on equivalent inch-size bearing for vibration data, screw data and lubrication details.

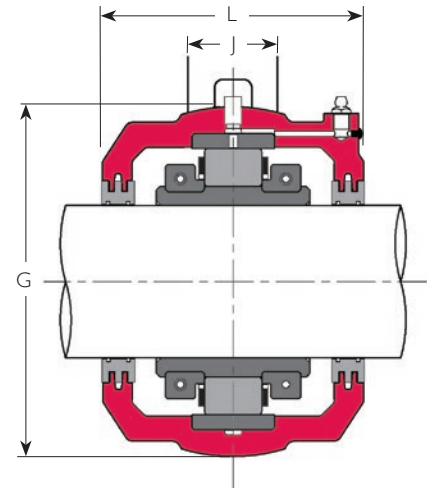
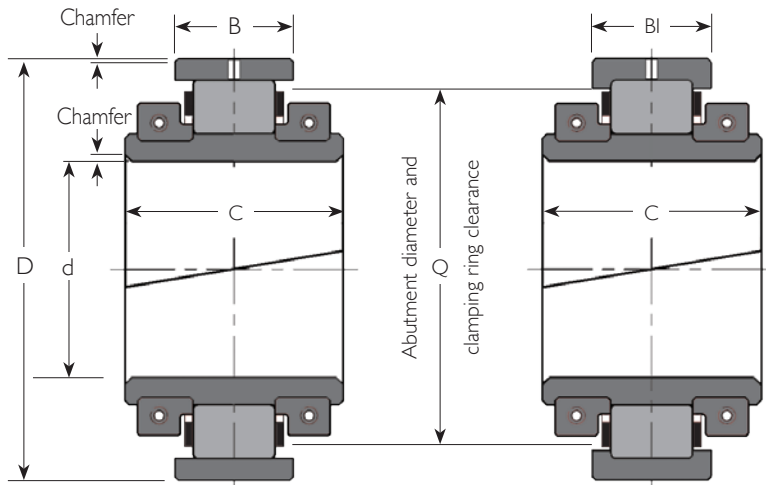

ROLLER BEARING

Shaft Dia. d (mm)	Reference (1)	Equivalent Inch-size Bearing (4)	Bearing Ratings				Principal Dimensions					Axial Movement (2)		
			Cr (kN)	Cor (kN)	Ca (kN)	Max. Speed (rpm)	D (mm)	C (mm)	B (mm)	BI (mm)	Q (mm)	Usual (mm)	Max. (mm)	Mass (kg)
80	01E B 80M	01E B 308	234	299	13.6	2790	152.40	70.7	38.9	38.9	142	6	10	4.0
	02 B 80M	02 B 308	280	345	17.8	2520	169.86	89.7	48.4	48.4	156	7	14	7.0
85	100 B 85M	01 B 307	142	209	12.3	3600	133.35	60.0	31.8	31.8	120	5	6	2.1
	01E B 85M	01E B 308	234	299	13.6	2790	152.40	70.7	38.9	38.9	142	6	10	4.0
	02 B 85M	02 B 308	280	345	17.8	2520	169.86	89.7	48.4	48.4	156	7	14	7.0
90	01E B 90M	01E B 308	234	299	13.6	2790	152.40	70.7	38.9	38.9	142	6	10	4.0
	02 B 90M	02 B 308	280	345	17.8	2520	169.86	89.7	48.4	48.4	156	7	14	7.0
95	01E B 95M	01E B 400	320	421	19.6	2340	174.62	81.0	45.3	45.3	162	7	10.5	6.0
100	100 B 100M	100 B 400	191	288	18.3	3090	152.40	65.0	38.9	38.9	140	6	9.0	2.8
	01E B 100M	01E B 400	320	421	19.6	2340	174.62	81.0	45.3	45.3	162	7	10.5	6.0
	02 B 100M	02 B 400	362	456	25.0	2130	193.68	92.1	51.6	51.6	178	8	13.5	9.0
	03 B 100M	03 B 400	610	684	31.2	1820	254.00	136.00	84.2	84.2	219	11	29	30
105	01E B 105M	01E B 400	320	421	19.6	2340	174.62	81.0	45.3	45.3	162	7	10.5	6.0
	02 B 105M	02 B 400	362	456	25.0	2130	193.68	92.1	51.6	51.6	178	8	13.5	9.0

CARTRIDGE

References (1)		Principal Dimensions				
Cartridge Only	Cartridge, Bearing and Seals	G (mm)	J (mm)	L (mm)	Mass (kg)	
01 C 05	01E BC 80M AT	177.80	50	136	7.0	
02 C 06	02 BC 80M AT	203.20	50	154	10.0	
100 C 04	100 BC 85M AT	157.16	38	114	5.4	
01 C 05	01E BC 85M AT	177.80	50	136	7.0	
02 C 06	02 BC 85M AT	203.20	50	154	10.0	
01 C 05	01E BC 90M AT	177.80	50	136	7.0	
02 C 06	02 BC 90M AT	203.20	50	154	10.0	
01 C 06	01E BC 95M AT	203.20	50	134	8.0	
100 C 05	100 BC 100M AT	177.80	50	136	7.4	
01 C 06	01E BC 100M AT	203.20	50	134	8.0	
02 C 07	02 BC 100M AT	231.78	64	146	12.0	
03 C 54	03 BC 100M AT	308.00	95	206	41.0	
01 C 06	01E BC 105M AT	203.20	50	134	8.0	
02 C 07	02 BC 105M AT	231.78	64	146	12.0	

1) Add 'EX' or 'GR' to reference for expansion type or fixed type respectively, eg:

bearing: 01E B 90M EX

cartridge: 01 C 05 EX

bearing, cartridge and seals: 01E BC 90M EX AT

complete unit: 01E BCP 90M EX AT

Pillow blocks are common between expansion and fixed typed units.

2) Total available axial movement given. Maximum offset from centerline half this amount. 'Usual' axial movement denotes maximum recommended range of running positions of EX bearing for optimum performance. 'Maximum' axial movement denotes available movement before bearing strikes inside of standard Cooper cartridge.

2 BOLT

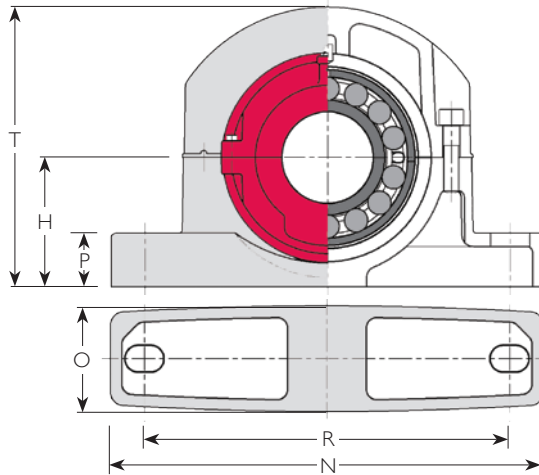

4 BOLT

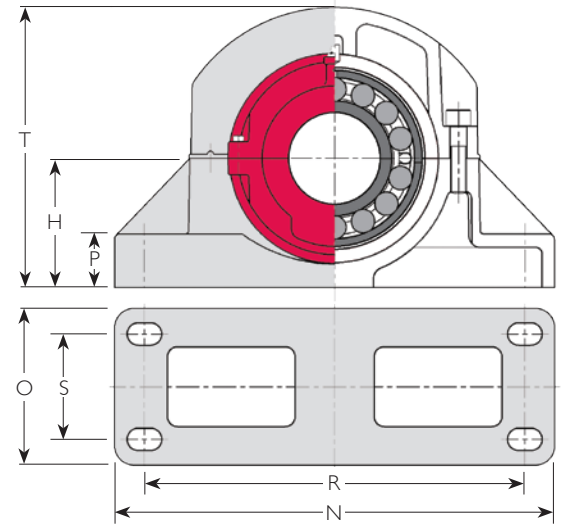

PILLOW BLOCK

References (I)		R		Bolts				Mass (kg)		Shaft Diameter d (mm)						
Pillow Block Only	Complete Unit	H (mm)	Min. (mm)	Max. (mm)	Ro (mm)	S (mm)	No.	Metric Size	Inch Size		N (mm)	O (mm)	P (mm)	T (mm)	Pillow Block Only (kg)	Complete Unit (kg)
P0510	01E BC4P 80M AT	112	316	340	-	88	4	M20	3/4"	380	140	44	252	15.3	26.3	80
P0613	02 BC4P 80M AT	125	356	380	-	102	4	M20	3/4"	426	152	52	272	20.2	37.2	
P04	100 BCP 85M AT	95	260	280	-	-	2	M20	3/4"	330	76	38	208	6.9	14.4	85
P0510	01E BC4P 85M AT	112	316	340	-	88	4	M20	3/4"	380	140	44	252	15.3	26.3	
P0613	02 BC4P 85M AT	125	356	380	-	102	4	M20	3/4"	426	152	52	272	20.2	37.2	
P0510	01E BC4P 90M AT	112	316	340	-	88	4	M20	3/4"	380	140	44	252	15.3	26.3	90
P0613	02 BC4P 90M AT	125	356	380	-	102	4	M20	3/4"	426	152	52	272	20.2	37.2	
P0613	01E BC4P 95M AT	125	356	380	-	102	4	M20	3/4"	426	152	52	272	20.2	37.2	95
P05	100 BCP 100M AT	112	312	328	-	-	2	M24	7/8"	380	90	44	252	13.3	23.5	100
P0613	01E BC4P 100M AT	125	356	380	-	102	4	M20	3/4"	426	152	52	272	20.2	34.2	
P0710	02 BC4P 100M AT	143	400	424	-	114	4	M20	3/4"	476	172	60	314	24.2	45.2	
P54	03 BCP 100M AT	191	426	450	-	82	4	M24	7/8"	514	152	38	405	61	132	
P0613	01E BC4P 105M AT	125	356	380	-	102	4	M20	3/4"	426	152	52	272	20.2	34.2	105
P0710	02 BC4P 105M AT	143	400	424	-	114	4	M20	3/4"	476	172	60	314	24.2	45.2	

3) Maximum fillet radii of abutments:

inner race: up to and including 90mm shaft size: 1.2mm
 over 90mm shaft size: 2mm

outer race: 01E and 02 Series up to and including 90mm shaft size, 100 Series: 0.4mm
 01E and 02 Series over 90mm shaft size: 0.8mm
 03 Series: 2mm

4) Refer to data on equivalent inch-size bearing for vibration data, screw data and lubrication details.

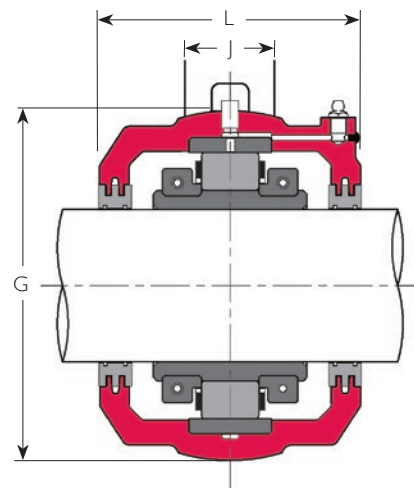
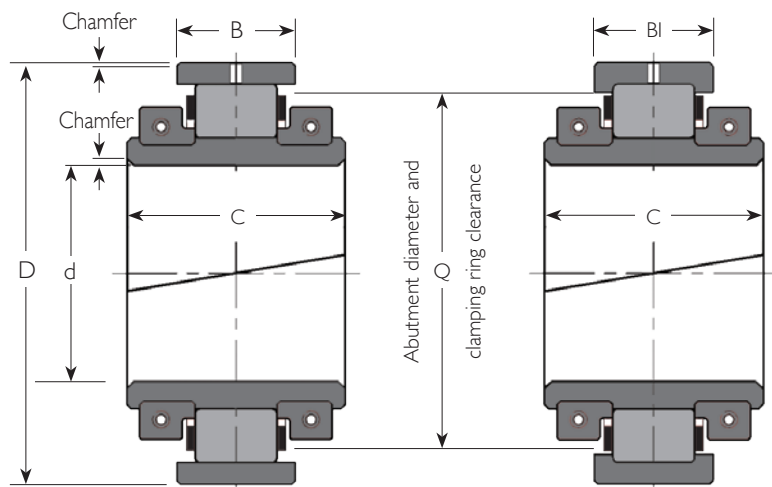

ROLLER BEARING

Shaft Dia. d (mm)	Reference (1)	Equivalent Inch-size Bearing (4)	Bearing Ratings				Principal Dimensions					Axial Movement (2)		
			Cr (kN)	Cor (kN)	Ca (kN)	Max. Speed (rpm)	D (mm)	C (mm)	B (mm)	BI (mm)	Q (mm)	Usual (mm)	Max. (mm)	Mass (kg)
110	100 B 110M	100 B 408	279	426	22.2	2750	174.62	80.0	45.3	45.3	160	7	9.5	4.6
	01 B 110M	01 B 408	306	407	18.6	1970	203.20	84.9	46.9	46.9	182	7	12.5	10.2
	02 B 110M	02 B 408	454	583	31.2	1820	228.60	100.0	57.2	57.2	202	9	13.5	16.0
	03 B 110M	03 B 408	614	698	39.2	1640	266.70	147.0	87.3	87.3	232	11	30	36.0
115	01 B 115M	01 B 408	306	407	18.6	1970	203.20	84.9	46.9	46.9	182	7	12.5	10.2
	02 B 115M	02 B 408	454	583	31.2	1820	228.60	100.0	57.2	57.2	202	9	13.5	16.0
120	100 B 120M	100 B 500	280	433	23.8	2480	203.20	85.0	46.9	46.9	180	7	11	7.4
	01 B 120M	01 B 500	355	484	22.2	1740	222.25	89.7	54.0	54.0	200	7	15	12.8
	02 B 120M	02 B 500	547	713	38.2	1600	254.00	114.3	63.5	63.5	224	10	15	20.0
	03 B 120M	03 B 500	614	698	39.2	1640	266.70	147.0	87.3	87.3	232	11	30	36.0
125	01 B 125M	01 B 500	355	484	22.2	1740	222.25	89.7	54.0	54.0	200	7	15	12.8
	02 B 125M	02 B 500	547	713	38.2	1600	254.00	114.3	63.5	63.5	224	10	15	20.0
130	100 B 130M	100 B 500	280	433	23.8	2480	203.20	85.0	46.9	46.9	180	7	11	7.4
	01 B 130M	01 B 500	355	484	22.2	1740	222.25	89.7	54.0	54.0	200	7	15	12.8
	02 B 130M	02 B 500	547	713	38.2	1600	254.00	114.3	63.5	63.5	224	10	15	20.0
	03 B 130M	03 B 500	706	852	49.0	1500	279.40	140.0	73.1	84.2	245	11	18	36.0

CARTRIDGE

References (1)	Principal Dimensions	References (1)	Principal Dimensions		
				Cartridge Only	Cartridge, Bearing and Seals
100 C 06	100 BC 110M AT	203.20	50	134	7.9
01 C 07	01 BC 110M AT	231.78	64	142	11.9
02 C 08	02 BC 110M AT	266.70	76	162	19.0
03 C 55	03 BC 110M AT	323.85	102	222	46.0
01 C 07	01 BC 115M AT	231.78	64	142	11.9
02 C 08	02 BC 115M AT	266.70	76	162	19.0
100 C 07	100 BC 120M AT	231.78	64	142	11.9
01 C 08	01 BC 120M AT	266.70	76	156	19.0
02 C 10	02 BC 120M AT	295.28	82	184	26.0
03 C 55	03 BC 120M AT	323.85	102	222	46.0
01 C 08	01 BC 125M AT	266.70	76	156	19.5
02 C 10	02 BC 125M AT	295.28	82	184	26.0
100 C 07	100 BC 130M AT	231.78	64	142	11.9
01 C 08	01 BC 130M AT	266.70	76	156	19.0
02 C 10	02 BC 130M AT	295.28	82	184	26.0
03 C 56	03 BC 130M AT	323.85	102	222	48.0

1) Add 'EX' or 'GR' to reference for expansion type or fixed type respectively, eg:
 bearing: 01E B 120M EX
 cartridge: 01 C 08 EX
 bearing, cartridge and seals: 01E BC 120M EX AT
 complete unit: 01E BCP 120M EX AT
 Pillow blocks are common between expansion and fixed typed units.

2) Total available axial movement given. Maximum offset from centerline half this amount. 'Usual' axial movement denotes maximum recommended range of running positions of EX bearing for optimum performance. 'Maximum' axial movement denotes available movement before bearing strikes inside of standard Cooper cartridge.

2 BOLT

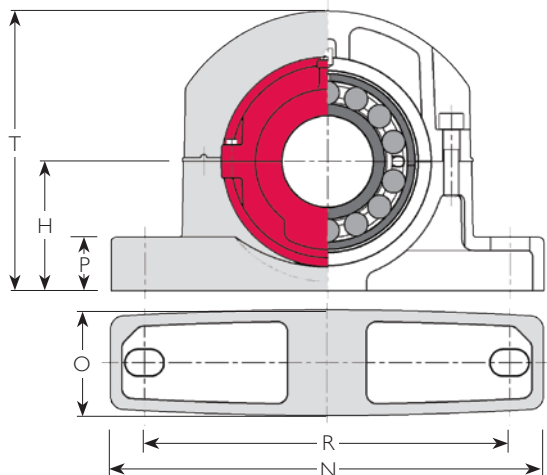

4 BOLT

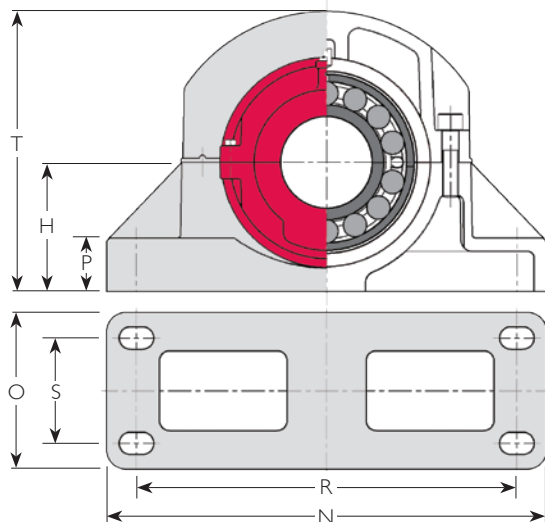

PILLOW BLOCK

References (I)		R					Bolts						Mass (kg)		Shaft Diameter d (mm)
Pillow Block Only	Complete Unit	H (mm)	Min. (mm)	Max. (mm)	Ro (mm)	S (mm)	No.	Metric Size	Inch Size	N (mm)	O (mm)	P (mm)	T (mm)	Pillow Block Only (kg)	
P06	100 BCP 110M AT	125	342	366	-	-	2	M24	7/8"	420	102	52	272	14.7	27.2
P0710	01 BC4P 110M AT	143	400	424	-	114	4	M20	3/4"	476	172	60	314	24.2	46.3
P08	02 BCP 110M AT	162	438	462	-	120	4	M24	7/8"	508	178	38	372	43.3	78
P55	03 BCP 110M AT	197	446	470	-	88	4	M24	1"	534	166	38	425	69	151
P0710	01 BC4P 115M AT	143	400	424	-	114	4	M20	3/4"	476	172	60	314	24.2	46.3
P08	02 BCP 115M AT	162	438	462	-	120	4	M24	7/8"	508	178	38	372	43.3	78
P07	100 BCP 120M AT	143	374	410	-	-	2	M24	7/8"	466	120	60	314	20.6	39.0
P08	01 BCP 120M AT	162	438	462	-	120	4	M24	7/8"	508	178	38	372	43.3	76
P10	02 BCP 120M AT	181	484	508	-	120	4	M24	7/8"	558	178	41	415	54	100
P55	03 BCP 120M AT	197	446	470	-	88	4	M24	1"	534	166	38	425	69	151
P08	01 BCP 125M AT	162	438	462	-	120	4	M24	7/8"	508	178	38	372	43.3	76
P10	02 BCP 125M AT	181	484	508	-	120	4	M24	7/8"	558	178	41	415	54	100
P07	100 BCP 130M AT	143	374	410	-	-	2	M24	7/8"	466	120	60	314	20.6	39.0
P08	01 BCP 130M AT	162	438	462	-	120	4	M24	7/8"	508	178	38	372	43.3	75.6
P10	02 BCP 130M AT	181	484	508	-	120	4	M24	7/8"	558	178	41	415	54	100
P56	03 BCP 130M AT	203	458	482	-	96	4	M24	1"	546	166	38	435	74	158

3) Maximum fillet radii of abutments:
 inner race: 2mm
 outer race: 100, 01 and 02 Series 0.8mm
 03 Series 2mm

4) Refer to data on equivalent inch-size bearing for vibration data, screw data and lubrication details.

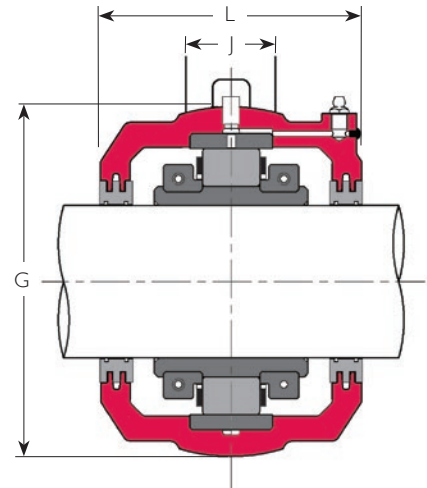
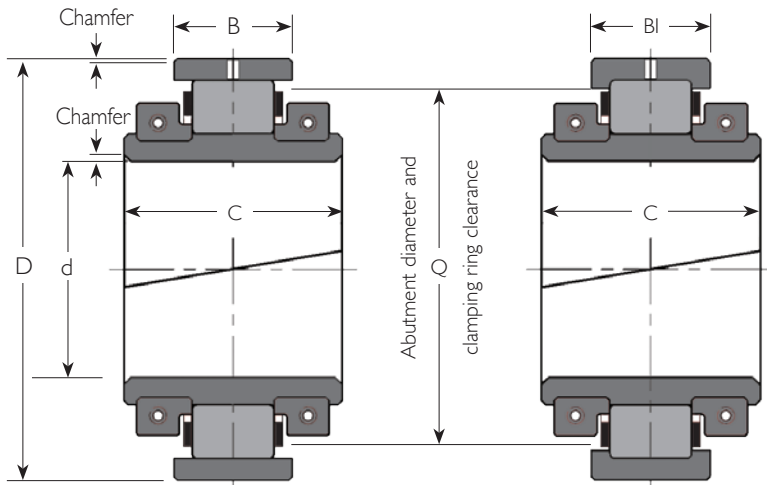

ROLLER BEARING

Shaft Dia. d (mm)	Reference (1)	Equivalent Inch-size Bearing (4)	Bearing Ratings				Principal Dimensions					Axial Movement (2)		
			Cr (kN)	Cor (kN)	Ca (kN)	Max. Speed (rpm)	D (mm)	C (mm)	B (mm)	BI (mm)	Q (mm)	Usual (mm)	Max. (mm)	Mass (kg)
135	01 B 135M	01 B 508	394	542	25.8	1570	241.30	98.4	55.6	55.6	216	8	16	15.0
	02 B 135M	02 B 508	608	808	45.4	1450	273.05	117.5	66.7	66.7	240	10	15	24.0
140	100 B 140M	100 B 508	331	520	30.5	2620	222.25	90.0	54.0	54.0	195	7	13	9.3
	01 B 140M	01 B 508	394	542	25.8	1570	241.30	98.4	55.6	55.6	216	8	16	15.0
	02 B 140M	02 B 508	608	808	45.4	1450	273.05	117.5	66.7	66.7	240	10	15	24.0
	03 B 140M	03 B 508	886	1069	58.8	1340	304.80	147.0	79.4	90.5	270	12	18	44.0
145	02 B 145M	02 B 508	608	808	45.4	1450	273.05	117.5	66.7	66.7	240	10	15	24.0
150	100 B 150M	100 B 600	397	606	31.4	2400	241.30	90.0	55.6	55.6	215	8	15.5	10.4
	01 B 150M	01 B 600	428	616	29.4	1450	254.00	98.4	55.6	55.6	230	8	16	16.6
	02 B 150M	02 B 600	724	1005	52.4	1320	292.10	123.8	68.3	68.3	258	10	15	29.0
	03 B 150M	03 B 600	994	1213	69.4	1220	330.20	160.0	81.0	96.9	292	13	16	57.0
155	01 B 155M	01 B 600	428	616	29.4	1450	254.00	98.4	55.6	55.6	230	8	16	16.6
	02 B 155M	02 B 600	724	1005	52.4	1320	292.10	123.8	68.3	68.3	258	10	15	29.0

CARTRIDGE

References (1)		Principal Dimensions			
Cartridge Only	Cartridge, Bearing and Seals	G (mm)	J (mm)	L (mm)	Mass (kg)
01 C 09	01 BC 135M AT	279.40	76	168	20.8
02 C 30	02 BC 135M AT	323.85	90	188	33.0
100 C 08	100 BC 140M AT	266.70	76	156	18.4
01 C 09	01 BC 140M AT	279.40	76	168	20.8
02 C 30	02 BC 140M AT	323.85	90	188	33.0
03 C 57	03 BC 140M AT	355.60	108	230	52
02 C 30	02 BC 145M AT	323.85	90	188	33.0
100 C 09	100 BC 150M AT	279.40	76	168	19.4
01 C 10	01 BC 150M AT	295.28	82	174	24.4
02 C 31	02 BC 150M AT	336.55	95	204	39.0
03 C 58	03 BC 150M AT	393.70	114	254	70
01 C 10	01 BC 155M AT	295.28	82	174	24.4
02 C 31	02 BC 155M AT	336.55	95	204	39.0

1) Add 'EX' or 'GR' to reference for expansion type or fixed type respectively, eg:
 bearing: 01E B 150M EX
 cartridge: 01 C 10 EX
 bearing, cartridge and seals: 01E BC 150M EX AT
 complete unit: 01E BCP 150M EX AT
 Pillow blocks are common between expansion and fixed typed units.

2) Total available axial movement given. Maximum offset from centerline half this amount. 'Usual' axial movement denotes maximum recommended range of running positions of EX bearing for optimum performance. 'Maximum' axial movement denotes available movement before bearing strikes inside of standard Cooper cartridge.

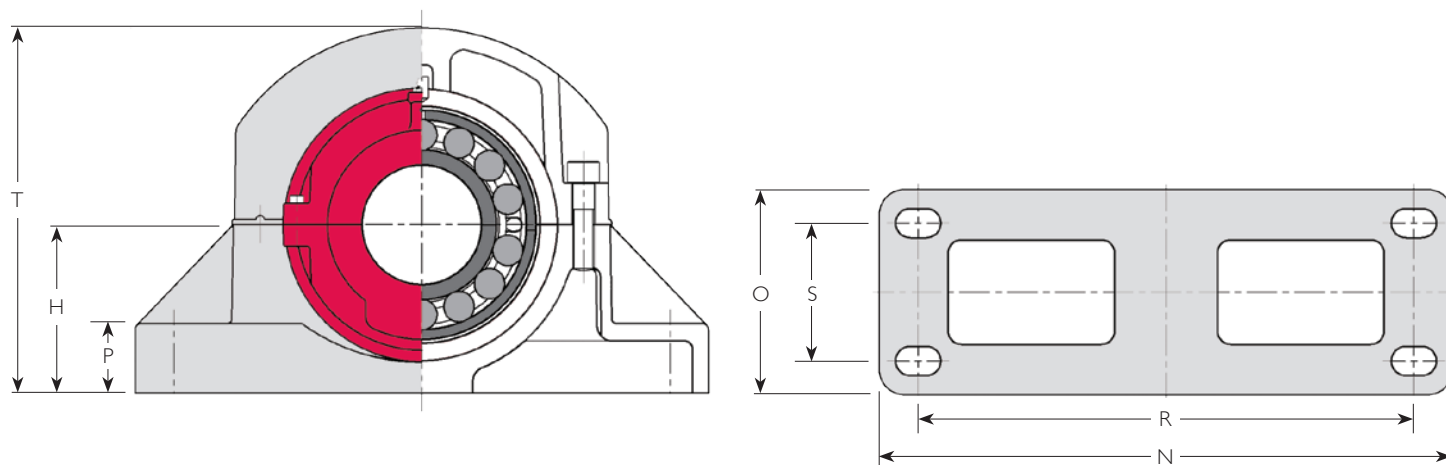

PILLOW BLOCK

References (I)		R					Bolts				Mass (kg)				Shaft Diameter d (mm)	
Pillow Block Only	Complete Unit	H (mm)	Min. (mm)	Max. (mm)	Ro (mm)	S (mm)	No.	Metric Size	Inch Size	N (mm)	O (mm)	P (mm)	T (mm)	Pillow Block Only (kg)		Complete Unit (kg)
P09	01 BCP 135M AT	181	470	494	-	120	4	M24	7/8"	558	178	41	405	52	88	135
P30	02 BCP 135M AT	203	534	558	-	120	4	M24	1"	610	178	51	460	76	133	
P08	100 BCP 140M AT	162	438	462	-	120	4	M24	7/8"	508	178	38	372	43.3	71	140
P09	01 BCP 140M AT	181	470	494	-	120	4	M24	7/8"	558	178	41	405	52	88	
P30	02 BCP 140M AT	203	534	558	-	120	4	M24	1"	610	178	51	460	76	133	
P57	03 BCP 140M AT	229	494	534	-	120	4	M30	1 1/4"	622	178	54	485	97	193	
P30	02 BCP 145M AT	203	534	558	-	120	4	M24	1"	610	178	51	460	76	133	
P09	100 BCP 150M AT	181	470	494	--	120	4	M24	7/8"	558	178	41	405	52	82	150
P10	01 BCP 150M AT	181	484	508	-	120	4	M24	7/8"	558	178	41	415	54	95	
P31	02 BCP 150M AT	210	546	570	-	128	4	M24	1"	636	204	50	470	83	151	
P58	03 BCP 150M AT	254	538	578	-	120	4	M30	1 1/4"	666	204	57	535	142	269	
P10	01 BCP 155M AT	181	484	508	-	120	4	M24	7/8"	558	178	41	415	54	95	155
P31	02 BCP 155M AT	210	546	570	-	128	4	M24	1"	636	204	50	470	83	151	

3) Maximum fillet radii of abutments:
 inner race: 2mm
 outer race: 100, 01 and 02 Series 0.8mm
 03 Series 2mm

4) Refer to data on equivalent inch-size bearing for vibration data, screw data and lubrication details.

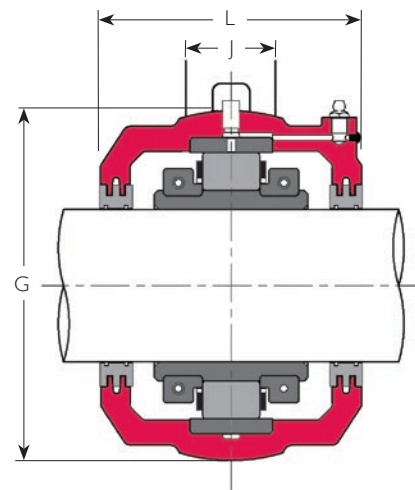
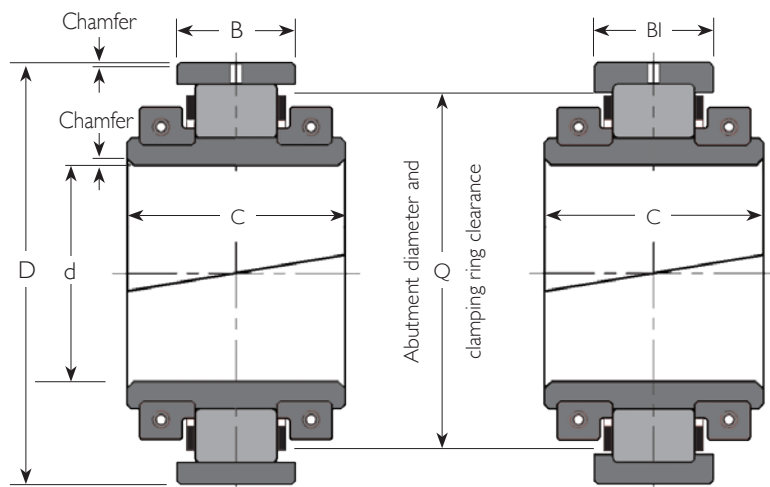

ROLLER BEARING

Shaft Dia. d (mm)	Reference (1)	Equivalent Inch-size Bearing (4)	Bearing Ratings				Principal Dimensions					Axial Movement (2)		
			Cr (kN)	Cor (kN)	Ca (kN)	Max. Speed (rpm)	D (mm)	C (mm)	B (mm)	BI (mm)	Q (mm)	Usual (mm)	Max. (mm)	Mass (kg)
160	01 B 600-160M	01 B 600	428	616	29.4	1450	254.00	98.4	55.6	55.6	230	8	16	16.6
	01E B 160M	01 B 608	594	863	56.5	1320	273.05	109.0	60.3	60.3	248	8	18	21.0
	02 B 600-160M	02 B 600	724	1005	52.4	1320	292.10	123.8	68.3	68.3	258	10	15	29.0
	02E B 160M	02 B 608	887	1262	71.2	1200	317.50	140.0	83.3	83.3	280	11	25	39.0
	03 B 160M	03 B 608	1156	1564	79.2	1110	355.60	171.0	103.2	103.2	308	14	31	72.0
170	01E B 608-170M	01 B 608	594	863	56.5	1320	273.05	109.0	60.3	60.3	248	8	18	21.0
	01E B 170M	01 B 700	557	845	52.2	1220	285.75	109.0	55.5	55.5	260	8	13.5	23.0
	02E B 170M	02 B 608	887	1262	71.2	1200	317.50	140.0	83.3	83.3	280	11	25	39.0
	03 B 170M	03 B 700	1156	1564	79.2	1110	355.60	171.0	103.2	103.2	308	14	31	72.0
175	01E B 175M	01 B 700	557	845	52.2	1220	285.75	109.0	55.5	55.5	260	8	13.5	23.0
	02E B 175M	02 B 700	936	1334	82.8	1120	330.20	140.0	83.3	83.3	294	11	25	45.0
180	01E B 180M	01 B 700	557	845	52.2	1220	285.75	109.0	55.5	55.5	260	8	13.5	23.0
	02E B 180M	02 B 700	936	1334	82.8	1120	330.20	140.0	83.3	83.3	294	11	25	45.0
	03 B 180M	03 B 700	1242	1704	89.0	1030	374.65	178.0	92.1	108.8	326	15	16	79.0
190	01E B 190M	01 B 800	679	1078	72.5	1070	311.15	109.0	60.3	60.3	285	8	18	25.0
	02E B 190M	02 B 800	1137	1627	122.0	960	368.30	156.0	90.5	90.5	328	13	26	59.0
	03 B 190M	03 B 800	1451	2022	99.6	880	419.10	191.0	97.7	118.3	366	16	16	105

CARTRIDGE

References (1)		Principal Dimensions			
Cartridge Only	Cartridge, Bearing and Seals	G (mm)	J (mm)	L (mm)	Mass (kg)
01 C 10 OTL	01 BC 600-160MAT	295.28	82	174	24.4
01 C 11	01E BC 160MAT	311.15	76	192	30.0
02 C 31 OTL	02 BC 600-160MAT	336.55	95	204	39.0
02 C 32	02E BC 160MAT	368.30	95	232	56
03 C 59	03 BC 160MAT	422.30	120	268	81
01 C 11 OTL	01E BC 608-170MAT	311.15	76	192	30.0
01 C 12	01E BC 170MAT	323.85	70	200	31.0
02 C 32 OTL	02E BC 170MAT	368.30	95	232	56
03 C 59	03 BC 170MAT	422.30	120	268	81
01 C 12	01E BC 175MAT	323.85	70	200	31.0
02 C 33	02E BC 175MAT	381.00	95	242	66
01 C 12	01E BC 180MAT	323.85	70	200	31.0
02 C 33	02E BC 180MAT	381.00	95	242	66
03 C 60	03 BC 180MAT	431.80	132	284	87
01 C 13	01E BC 190MAT	358.78	86	200	41.0
02 C 34	02E BC 190MAT	425.50	105	258	84
03 C 61	03 BC 190MAT	489.00	146	300	109

1) Add 'EX' or 'GR' to reference for expansion type or fixed type respectively, eg:
 bearing: 01E B 175M EX
 cartridge: 01 C 12 EX
 bearing, cartridge and seals: 01E BC 175M EX AT
 complete unit: 01E BCP 175M EX AT
 Pillow blocks are common between expansion and fixed typed units.

2) Total available axial movement given. Maximum offset from centerline half this amount. 'Usual' axial movement denotes maximum recommended range of running positions of EX bearing for optimum performance. 'Maximum' axial movement denotes available movement before bearing strikes inside of standard Cooper cartridge.

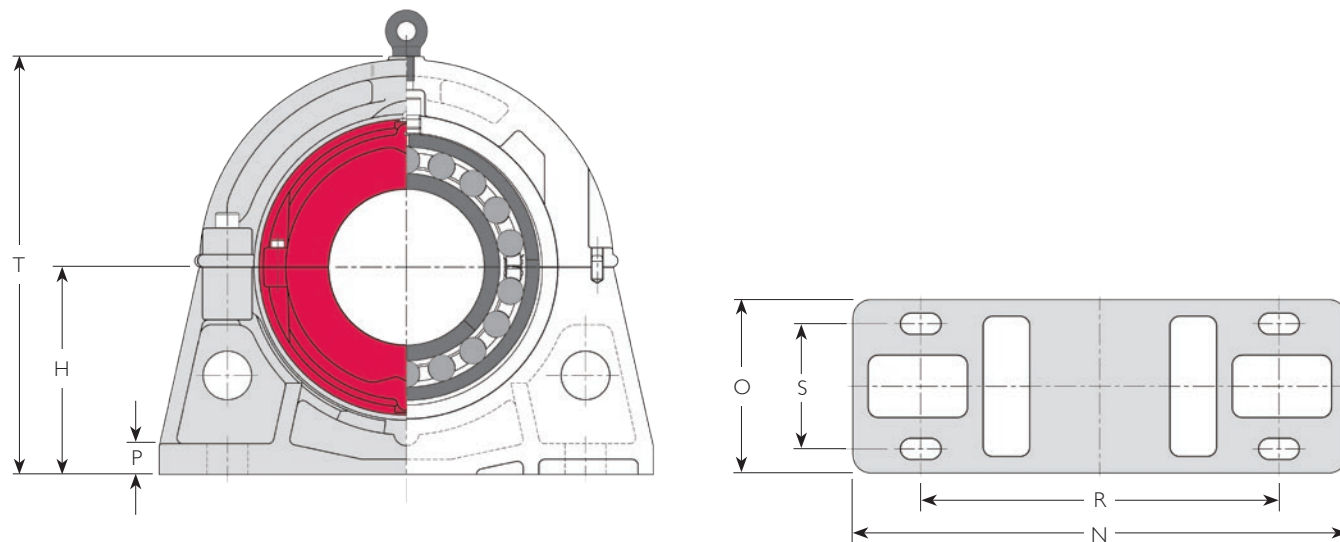

PILLOW BLOCK

References (1)		R					Bolts				Mass (kg)				Shaft Diameter d (mm)
Pillow Block Only	Complete Unit	H (mm)	Min. (mm)	Max. (mm)	Ro (mm)	S (mm)	No.	Metric Size	Inch Size	N (mm)	O (mm)	P (mm)	T (mm)	Pillow Block Only (kg)	
P10*	01 BCP 600-160M AT	181	484	508	-	120	4	M24	7/8"	558	178	41	415	54	95
P11	01E BCP 160M AT	213	356	380	-	114	4	M24	1"	508	178	32	430	53	104
P31*	02 BCP 600-160M AT	210	546	570	-	128	4	M24	1"	636	204	50	470	83	151
P32	02E BCP 160M AT	267	428	468	-	172	4	M30	1 1/4"	596	242	44	535	106	201
P59	03 BCP 160M AT	267	608	648	-	140	4	M30	1 1/4"	736	228	60	570	162	315
P11	01E BCP 608-170M AT	213	356	380	-	114	4	M24	1"	508	178	32	430	53	104
P12	01E BCP 170M AT	235	376	400	-	128	4	M24	1"	534	190	35	470	63	117
P32	02E BCP 170M AT	267	428	468	-	172	4	M30	1 1/4"	596	242	44	535	106	201
P59	03 BCP 170M AT	267	608	648	-	140	4	M30	1 1/4"	736	228	60	570	162	315
P12	01E BCP 175M AT	235	376	400	-	128	4	M24	1"	534	190	35	470	63	117
P33	02E BCP 175M AT	273	438	478	-	166	4	M30	1 1/4"	636	242	44	545	116	227
P12	01E BCP 180M AT	235	376	400	-	128	4	M24	1"	534	190	35	470	63	117
P33	02E BCP 180M AT	273	438	478	-	166	4	M30	1 1/4"	636	242	44	545	116	227
P60	03 BCP 180M AT	279	616	656	-	152	4	M30	1 1/4"	762	254	64	580	172	338
P13	01E BCP 190M AT	248	410	434	-	140	4	M24	1"	572	204	38	495	83	149
P34	02E BCP 190M AT	305	488	528	-	190	4	M30	1 1/4"	686	266	50	610	145	288
P61	03 BCP 190M AT	311	616	656	-	172	4	M36	1 1/2"	838	266	67	655	223	437

* Pillow blocks marked with an asterisk are of the style illustrated on page 61.

- 3) Maximum fillet radii of abutments:
 inner race: 01B 600-160M: 2mm
 others: 2.3mm
 outer race: 01B 600-160M: 0.8mm
 others: 2mm

- 4) Refer to data on equivalent inch-size bearing for vibration data, screw data and lubrication details.

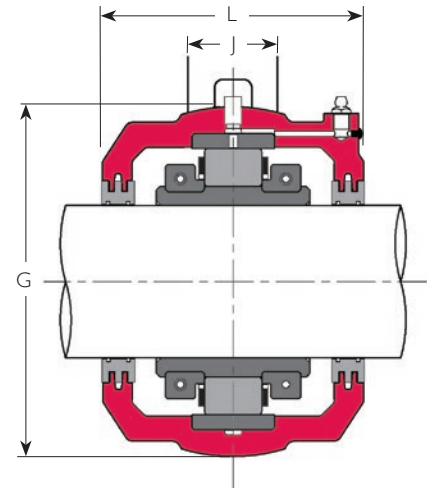
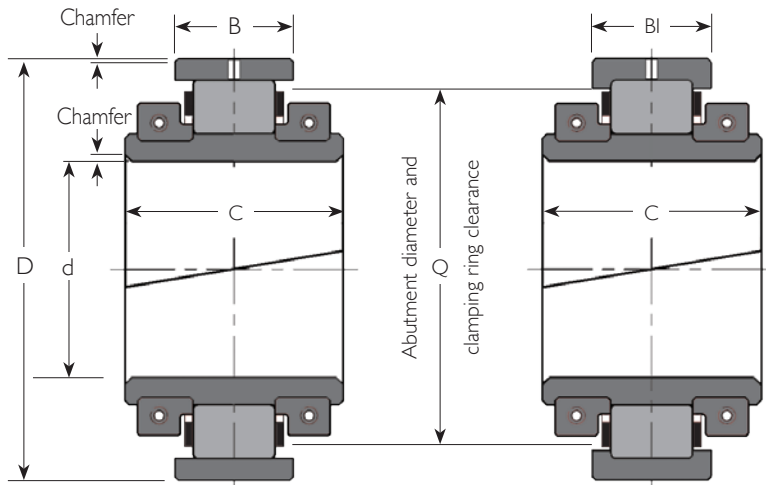

ROLLER BEARING

Shaft Dia. d (mm)	Reference (1)	Equivalent Inch-size Bearing (4)	Bearing Ratings				Principal Dimensions					Axial Movement (2)		Mass (kg)
			Cr (kN)	Cor (kN)	Ca (kN)	Max. Speed (rpm)	D (mm)	C (mm)	B (mm)	BI (mm)	Q (mm)	Usual (mm)	Max. (mm)	
200	01E B 200M	01 B 800	679	1078	72.5	1070	311.15	109.0	60.3	60.3	285	8	18	25.0
	02E B 200M	02 B 800	1137	1627	122	960	368.30	156.0	90.5	90.5	328	13	26	59.0
	03 B 200M	03 B 800	1451	2022	99.6	880	419.10	191.0	97.7	118.3	366	16	16	105
220	01E B 220M	01 B 900	715	1191	79.8	930	342.90	115.0	63.5	63.5	315	8	19	32
	02E B 220M	02 B 900	1233	1863	138	850	393.70	163.0	90.5	90.5	354	13	26	68
	03 B 220M	03 B 900	1586	2163	109.4	760	469.90	212.0	109.6	131.8	410	18	18	145
230	01E B 230M	01 B 900	715	1191	79.8	930	342.90	115.0	63.5	63.5	315	8	19	32
	02E B 230M	02 B 900	1233	1863	138	850	393.70	163.0	90.5	90.5	354	13	26	68
240	01E B 240M	01 B 1000	804	1367	96.6	820	374.65	122.0	66.7	66.7	344	9	22	40
	02E B 240M	02 B 1000	1346	1986	167	750	431.80	170.0	96.8	96.8	388	13	29	77
	03 B 240M	03 B 1000	1778	2551	131	700	482.60	211.0	105.6	124.6	430	18	33	150
250	01E B 250M	01 B 1000	804	1367	96.6	820	374.65	122.0	66.7	66.7	344	9	22	40
	02E B 250M	02 B 1000	1346	1986	167	750	431.80	170.0	96.8	96.8	388	13	29	77
	03 B 250M	03 B 1000	1778	2551	131	700	482.60	211.0	105.6	124.6	430	18	33	150

CARTRIDGE

Cartridge Only	References (1)	Cartridge, Bearing and Seals	Principal Dimensions				Mass (kg)
			G (mm)	J (mm)	L (mm)		
01 C 13	01E BC 200M AT	01E BC 200M AT	358.78	86	200	41.0	
02 C 34	02E BC 200M AT	02E BC 200M AT	425.50	105	258	84	
03 C 61	03 BC 200M AT	03 BC 200M AT	489.00	146	300	109	
01 C 14	01E BC 220M AT	01E BC 220M AT	387.35	82	216	46.0	
02 C 35	02E BC 220M AT	02E BC 220M AT	457.20	110	274	98	
03 C 62	03 BC 220M AT	03 BC 220M AT	546.10	165	334	155	
01 C 14	01E BC 230M AT	01E BC 230M AT	387.35	82	216	46.0	
02 C 35	02E BC 230M AT	02E BC 230M AT	457.20	110	274	98	
01 C 15	01E BC 240M AT	01E BC 240M AT	419.10	90	222	58	
02 C 36	02E BC 240M AT	02E BC 240M AT	495.30	118	280	105	
03 C 63	03 BC 240M AT	03 BC 240M AT	558.80	165	334	161	
01 C 15	01E BC 250M AT	01E BC 250M AT	419.10	90	222	58	
02 C 36	02E BC 250M AT	02E BC 250M AT	495.30	118	280	105	
03 C 63	03 BC 250M AT	03 BC 250M AT	558.80	165	334	161	

1) Add 'EX' or 'GR' to reference for expansion type or fixed type respectively, eg:
 bearing: 01E B 200M EX
 cartridge: 01 C 13 EX
 bearing, cartridge and seals: 01E BC 200M EX AT
 complete unit: 01E BCP 200M EX AT
 Pillow blocks are common between expansion and fixed typed units.

2) Total available axial movement given. Maximum offset from centerline half this amount. 'Usual' axial movement denotes maximum recommended range of running positions of EX bearing for optimum performance. 'Maximum' axial movement denotes available movement before bearing strikes inside of standard Cooper cartridge.

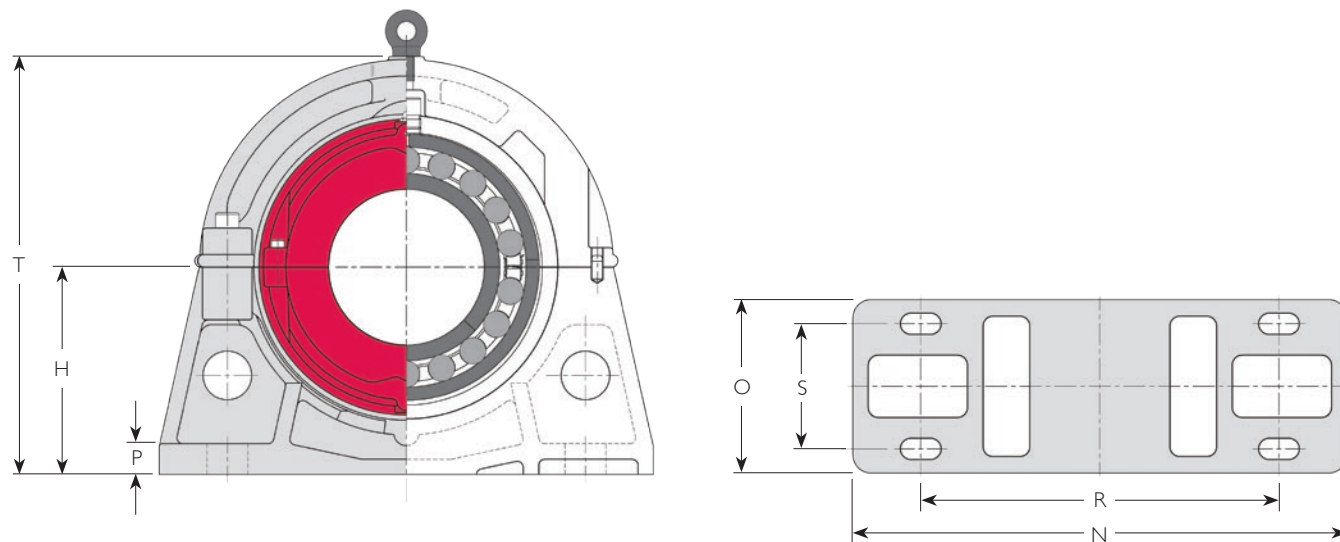

PILLOW BLOCK

References (I)		R					Bolts					Mass (kg)		Shaft Diameter d (mm)		
Pillow Block Only	Complete Unit	H (mm)	Min. (mm)	Max. (mm)	Ro (mm)	S (mm)	No.	Metric Size	Inch Size	N (mm)	O (mm)	P (mm)	T (mm)		Pillow Block Only (kg)	Complete Unit (kg)
P13	01E BCP 200M AT	248	410	434	-	140	4	M24	1"	572	204	38	495	83	149	200
P34	02E BCP 200M AT	305	488	528	-	190	4	M30	1 1/4"	686	266	50	610	145	288	
P61	03 BCP 200M AT	311	616	656	-	172	4	M36	1 1/2"	838	266	67	655	223	437	
P14	01E BCP 220M AT	270	440	480	-	140	4	M30	1 1/4"	636	216	40	540	90	168	220
P35	02E BCP 220M AT	324	530	570	-	190	4	M36	1 1/2"	750	280	50	650	179	345	
P62	03 BCP 220M AT	349	716	756	-	178	4	M42	1 3/4"	952	280	76	730	309	609	
P14	01E BCP 230M AT	270	440	480	-	140	4	M30	1 1/4"	636	216	40	540	90	168	230
P35	02E BCP 230M AT	324	530	570	-	190	4	M36	1 1/2"	750	280	50	650	179	345	
P15	01E BCP 240M AT	292	482	522	-	140	4	M30	1 1/4"	686	228	44	585	114	212	240
P36	02E BCP 240M AT	356	576	616	-	204	4	M36	1 1/2"	812	292	54	710	212	394	
P63	03 BCP 240M AT	394	650	690	-	304	4	M42	1 3/4"	914	406	76	790	392	703	
P15	01E BCP 250M AT	292	482	522	-	140	4	M30	1 1/4"	686	228	44	585	114	212	250
P36	02E BCP 250M AT	356	576	616	-	204	4	M36	1 1/2"	812	292	54	710	212	394	
P63	03 BCP 250M AT	394	650	690	-	304	4	M42	1 3/4"	914	406	76	790	392	703	

3) Maximum fillet radii of abutments:
 inner race: 2.3mm
 outer race: 2mm

4) Refer to data on equivalent inch-size bearing for vibration data, screw data and lubrication details.

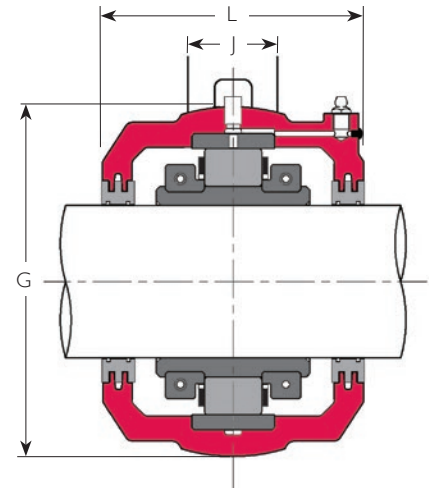
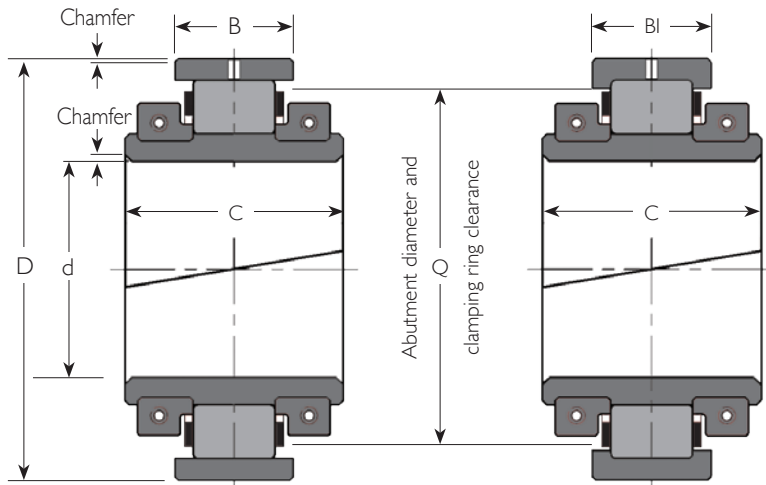

ROLLER BEARING

Shaft Dia. d (mm)	Reference (1)	Equivalent Inch-size Bearing (4)	Bearing Ratings				Principal Dimensions					Axial Movement (2)		
			Cr (kN)	Cor (kN)	Ca (kN)	Max. Speed (rpm)	D (mm)	C (mm)	B (mm)	BI (mm)	Q (mm)	Usual (mm)	Max. (mm)	Mass (kg)
260	01E B 1000-260M	01 B 1000	804	1367	96.6	820	374.65	122.0	66.7	66.7	344	9	22	40
	01E B 260M	01 B 1000	917	1560	127	730	406.40	128.0	69.0	69.0	375	10	20	50
	02E B 260M	02 B 1000	1346	1986	167	750	431.80	170.0	96.8	96.8	388	13	29	77
	03 B 260M	03 B 1000	1778	2551	131	700	482.60	211.0	105.6	124.6	430	18	33	150
270	01E B 270M	01 B 1100	917	1560	127	730	406.40	128.0	69.0	69.0	375	10	20	50
275	01E B 275M	01 B 1100	917	1560	127	730	406.40	128.0	69.0	69.0	375	10	20	50
280	01E B 280M	01 B 1100	917	1560	127	730	406.40	128.0	69.0	69.0	375	10	20	50
	02E B 280M	02 B 1100	1545	2435	190	670	463.55	186.0	101.6	101.6	420	14	29	86
	03X B 280M	03X B 1100	1956	2960	153	620	520.70	231.0	131.8	131.8	462	18	40	197
	03E B 280M	03E B 1100	2105	3233	153	620	495.30	244.0	139.7	139.7	452	20	34	182
290	01E B 290M	01 B 1200	1041	1885	139	650	438.15	143.0	74.6	74.6	404	10	25	60
	03 B 290M	03 B 1200	2156	3312	174	560	558.80	244.0	139.7	139.7	496	19	43	238
300	01E B 300M	01 B 1200	1041	1885	139	650	438.15	143.0	74.6	74.6	404	10	25	60
	02E B 300M	02 B 1200	1660	2735	214	610	495.30	193.0	103.2	103.2	448	14	30	123
	03 B 300M	03 B 1200	2156	3312	174	560	558.80	244.0	139.7	139.7	496	19	43	238

CARTRIDGE

References (1)		Principal Dimensions			
Cartridge Only	Cartridge, Bearing and Seals	G (mm)	J (mm)	L (mm)	Mass (kg)
01 C 15 OTL	01E BC 1000-260M AT	419.10	90	222	58
01 C 16	01E BC 260M AT	454.00	95	232	70
02 C 36 OTL	02E BC 260M AT	495.30	118	280	105
03 C 63	03 BC 260M AT	558.80	165	334	161
01 C 16	01E BC 270M AT	454.00	95	232	70
01 C 16	01E BC 275M AT	454.00	95	232	70
01 C 16	01E BC 280M AT	454.00	95	232	70
02 C 37	02E BC 280M AT	527.10	130	300	131
03X C 64	03X BC 280M AT	596.90	165	352	200
03E C 83	03E BC 280M AT	571.50	165	356	204
01 C 17	01E BC 290M AT	489.00	98	248	86
03 C 65	03 BC 290M AT	641.40	165	370	239
01 C 17	01E BC 300M AT	489.00	98	248	86
02 C 38	02E BC 300M AT	552.50	128	306	129
03 C 65	03 BC 300M AT	641.40	165	370	239

1) Add 'EX' or 'GR' to reference for expansion type or fixed type respectively, eg:
 bearing: 01E B 280M EX
 cartridge: 01 C 16 EX
 bearing, cartridge and seals: 01E BC 280M EX AT
 complete unit: 01E BCP 280M EX AT
 Pillow blocks are common between expansion and fixed typed units.

2) Total available axial movement given. Maximum offset from centerline half this amount. 'Usual' axial movement denotes maximum recommended range of running positions of EX bearing for optimum performance. 'Maximum' axial movement denotes available movement before bearing strikes inside of standard Cooper cartridge.

4 BOLT

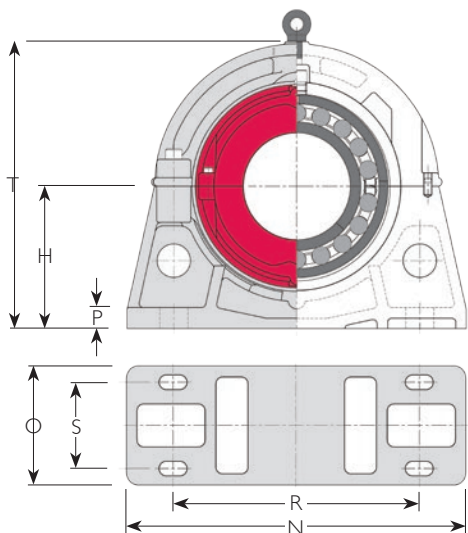

8 BOLT

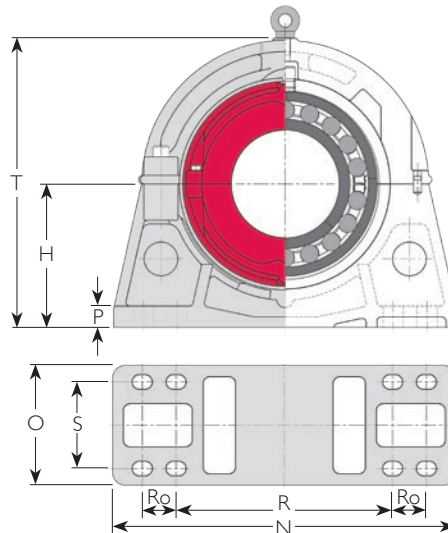

PILLOW BLOCK

References (I)		R					Bolts						Mass (kg)		Shaft Diameter d (mm)	
Pillow Block Only	Complete Unit	H (mm)	Min. (mm)	Max. (mm)	Ro (mm)	S (mm)	No.	Metric Size	Inch Size	N (mm)	O (mm)	P (mm)	T (mm)	Pillow Block Only (kg)		Complete Unit (kg)
P15	01E BCP 1000-260M AT	292	482	522	-	140	4	M30	1 1/4"	686	228	44	585	114	212	260
P16	01E BCP 260M AT	311	514	554	-	140	4	M30	1 1/4"	724	228	48	620	142	262	
P36	02E BCP 260M AT	356	576	616	-	204	4	M36	1 1/2"	812	292	54	710	212	394	
P63	03 BCP 260M AT	394	650	690	-	304	4	M42	1 3/4"	914	406	76	790	392	703	
P16	01E BCP 270M AT	311	514	554	-	140	4	M30	1 1/4"	724	228	48	620	142	262	270
P16	01E BCP 275M AT	311	514	554	-	140	4	M30	1 1/4"	724	228	48	620	142	262	275
P16	01E BCP 280M AT	311	514	554	-	140	4	M30	1 1/4"	724	228	48	620	142	262	280
P37	02E BCP 280M AT	378	514	554	101	254	8	M30	1 1/4"	914	330	60	760	292	509	
P64	03X BCP 280M AT	425	590	630	101	318	8	M36	1 1/2"	1028	406	76	850	495	892	
P68	03E BCP 280M AT	368	482	522	120	178	8	M36	1 1/2"	940	280	70	785	205	591	
P17	01E BCP 290M AT	343	564	604	-	178	4	M30	1 1/4"	762	254	50	685	169	315	290
P65	03 BCP 290M AT	457	654	694	101	330	8	M36	1 1/2"	1092	420	76	915	586	1063	
P17	01E BCP 300M AT	343	564	604	-	178	4	M30	1 1/4"	762	254	50	685	169	315	300
P38	02E BCP 300M AT	394	546	586	101	254	8	M30	1 1/4"	958	330	60	790	330	582	
P65	03 BCP 300M AT	457	654	694	101	330	8	M36	1 1/2"	1092	420	76	915	586	1063	

3) Maximum fillet radii of abutments:
 inner race: 2.3mm
 outer race: 2mm

4) Refer to data on equivalent inch-size bearing for vibration data, screw data and lubrication details.

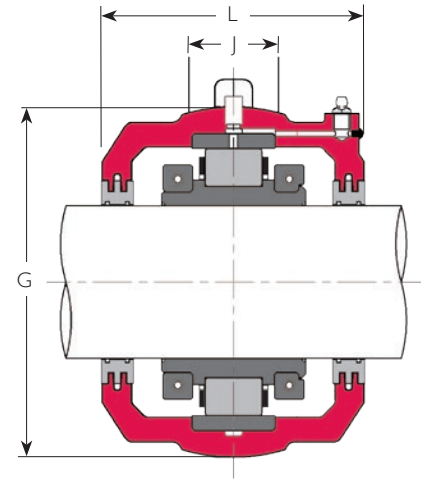
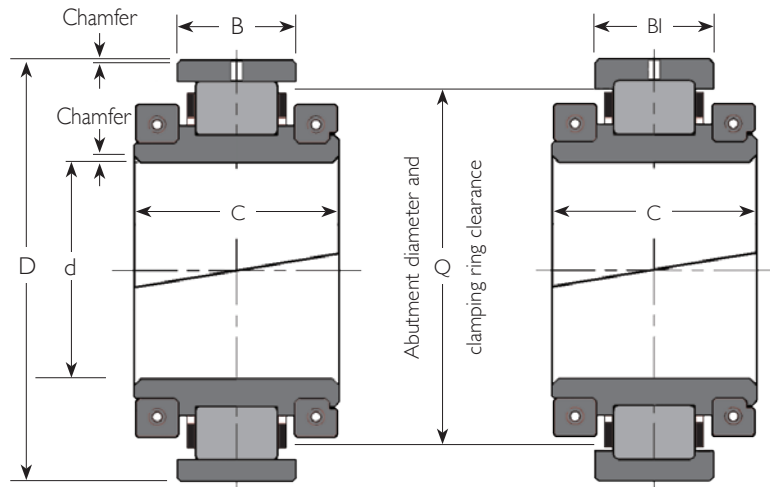

ROLLER BEARING

Shaft Dia. d (mm)	Reference (1)	Equivalent Inch-size Bearing (4)	Bearing Ratings				Principal Dimensions					Axial Movement (2)		
			Cr (kN)	Cor (kN)	Ca (kN)	Max. Speed (rpm)	D (mm)	C (mm)	B (mm)	BI (mm)	Q (mm)	Usual (mm)	Max. (mm)	Mass (kg)
320	01 B 320M	01 B 1300	894	1638	89.0	590	463.55	136.0	74.6	74.6	432	10	23	72
	02 B 320M	02 B 1300	1570	2622	144	550	527.05	192.0	106.4	106.4	478	15	30	150
	03 B 320M	03 B 1300	2529	3795	199	500	622.30	272.0	160.4	106.4	550	22	48	327
330	01 B 330M	01 B 1300	894	1638	89.0	590	463.55	136.0	74.6	74.6	432	10	23	72
	02 B 330M	02 B 1300	1570	2622	144	550	527.05	192.0	106.4	106.4	478	15	30	150
340	01 B 1300-340M	01 B 1300	894	1638	89.0	590	463.55	136.0	74.6	74.6	432	10	23	72
	01 B 340M	01 B 1400	935	1774	99.6	540	488.95	136.0	74.6	74.6	456	10	23	78
	02 B 340M	02 B 1400	1744	2940	159	500	565.15	200.0	115.9	115.9	514	16	35	182
	03E B 340M	03E B 1400	2750	4392	214	460	615.95	279.0	158.0	158.0	556	22	44	318
350	01 B 350M	01 B 1400	935	1774	99.6	540	488.95	136.0	74.6	74.6	456	10	23	78
	02 B 350M	02 B 1400	1744	2940	159	500	565.15	200.0	115.9	115.9	514	16	35	182
360	01 B 1400-360M	01 B 1400	935	1774	99.6	540	488.95	136.0	74.6	74.6	456	10	23	78
	01 B 360M	01 B 1500	1005	1925	110	500	520.70	140.0	76.2	76.2	486	10	23	86
	02 B 360M	02 B 1400	1744	2940	159	500	565.15	200.0	115.9	115.9	514	16	35	182
	03E B 360M	03E B 1400	2750	4392	214	460	615.95	279.0	158.0	158.0	556	22	44	318
	03X B 360M	03X B 1400	2785	4377	226	460	647.70	279.0	160.4	160.4	575	22	48	372

CARTRIDGE

References (1)	Principal Dimensions	References (1)				Principal Dimensions			
		Cartridge Only	Cartridge, Bearing and Seals	G (mm)	J (mm)	L (mm)	Mass (kg)		
01 C 18	01 BC 320M AT	520.70	95	272	106				
02 C 39	02 BC 320M AT	587.40	128	330	172				
03 C 66	03 BC 320M AT	717.60	170	418	273				
01 C 18	01 BC 330M AT	520.70	95	272	106				
02 C 39	02 BC 330M AT	587.40	128	330	172				
01 C 18	01 BC 1300-340M AT	520.70	95	272	106				
01 C 19	01 BC 340M AT	546.10	98	272	117				
02 C 40	02 BC 340M AT	628.70	146	342	186				
03E C 86	03E BC 340M AT	704.90	196	432	385				
01 C 19	01 BC 350M AT	546.10	98	272	117				
02 C 40	02 BC 350M AT	628.70	146	342	186				
01 C 19	01 BC 1400-360M AT	546.10	98	272	117				
01 C 20	01 BC 360M AT	571.50	98	280	126				
02 C 40	02 BC 360M AT	628.70	146	342	186				
03E C 86	03E BC 360M AT	704.90	196	432	385				
03X C 67	03X BC 360M AT	739.80	196	426	353				

1) Add 'EX' or 'GR' to reference for expansion type or fixed type respectively, eg:
 bearing: 01 B 340M EX
 cartridge: 01 C 19 EX
 bearing, cartridge and seals: 01 BC 340M EX AT
 complete unit: 01 BCP 340M EX AT
 Pillow blocks are common between expansion and fixed typed units.

2) Total available axial movement given. Maximum offset from centerline half this amount. 'Usual' axial movement denotes maximum recommended range of running positions of EX bearing for optimum performance. 'Maximum' axial movement denotes available movement before bearing strikes inside of standard Cooper cartridge.

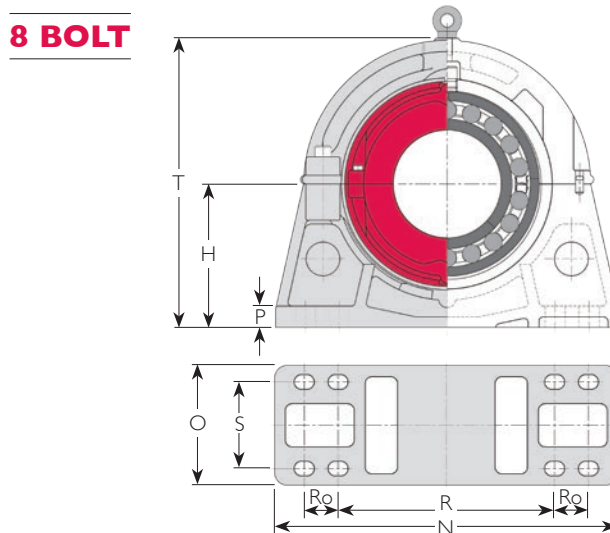
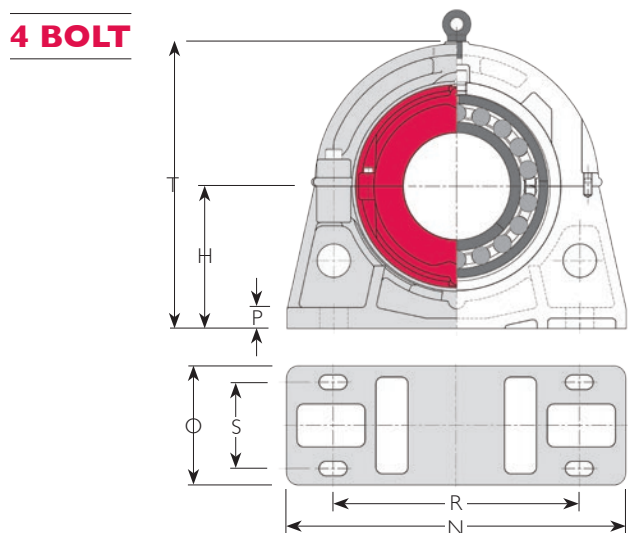

PILLOW BLOCK

References (I)		R					Bolts				Mass (kg)				Shaft Diameter d (mm)
Pillow Block Only	Complete Unit	H (mm)	Min. (mm)	Max. (mm)	Ro (mm)	S (mm)	No.	Metric Size	Inch Size	N (mm)	O (mm)	P (mm)	T (mm)	Pillow Block Only (kg)	
P18	01 BCP 320M AT	368	602	642	-	178	4	M36	1 1/2"	812	254	54	735	196	374
P39	02 BCP 320M AT	419	590	630	101	210	8	M30	1 1/4"	1016	292	64	840	383	705
P66	03 BCP 320M AT	518	742	782	108	266	8	M36	1 1/2"	1194	356	80	1035	655	1255
P18	01 BCP 330M AT	368	602	642	-	178	4	M36	1 1/2"	812	254	54	735	196	374
P39	02 BCP 330M AT	419	590	630	101	210	8	M30	1 1/4"	1016	292	64	840	383	705
P16	01 BCP 1300-340M AT	368	602	642	-	178	4	M36	1 1/2"	812	254	54	735	196	374
P19	01 BCP 340M AT	387	634	674	-	166	4	M36	1 1/2"	850	254	57	775	213	408
P40	02 BCP 340M AT	451	640	680	102	280	8	M36	1 1/2"	1092	368	67	900	429	797
P86	03E BCP 340M AT	470	634	686	134	190	8	M42	1 3/4"	1220	318	82	1000	464	1167
P19	01 BCP 350M AT	387	634	674	-	166	4	M36	1 1/2"	850	254	57	775	213	408
P40	02 BCP 350M AT	451	640	680	102	280	8	M36	1 1/2"	1092	368	67	900	429	797
P19	01 BCP 1400-360M AT	387	634	674	-	166	4	M36	1 1/2"	850	254	57	775	213	408
P20	01 BCP 360M AT	397	656	696	-	166	4	M36	1 1/2"	902	254	60	795	288	500
P40	02 BCP 360M AT	451	640	680	102	280	8	M36	1 1/2"	1092	368	67	900	429	797
P86	03E BCP 360M AT	470	634	686	134	190	8	M42	1 3/4"	1220	318	82	1000	464	1167
P67	03X BCP 360M AT	533	758	810	114	266	8	M42	1 3/4"	1244	368	90	1065	820	1545

3) Maximum fillet radii of abutments:
 inner race: 2.3mm
 outer race: 2mm

4) Refer to data on equivalent inch-size bearing for vibration data, screw data and lubrication details.

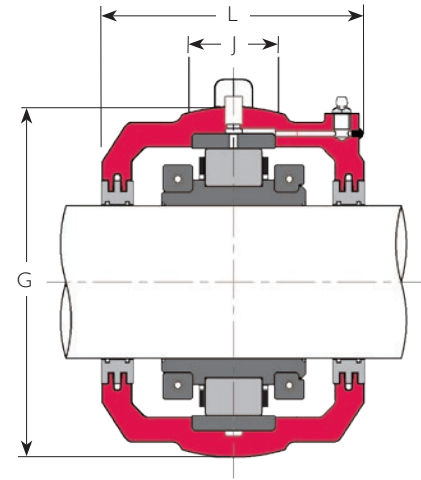
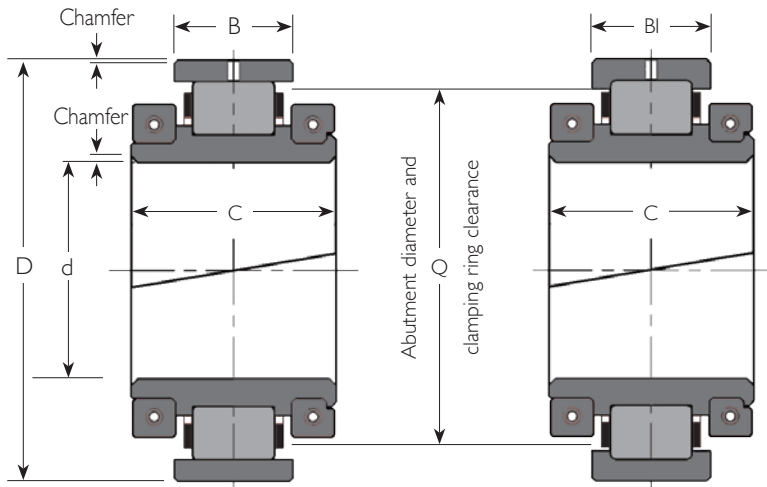

ROLLER BEARING

Shaft Dia. d (mm)	Reference (1)	Equivalent Inch-size Bearing (4)	Bearing Ratings				Principal Dimensions					Axial Movement (2)		
			Cr (kN)	Cor (kN)	Ca (kN)	Max. Speed (rpm)	D (mm)	C (mm)	B (mm)	BI (mm)	Q (mm)	Usual (mm)	Max. (mm)	Mass (kg)
380	01 B 380M	01 B 1500	1005	1925	110	500	520.70	140.0	76.2	76.2	486	10	23	86
	02 B 380M	02 B 1500	1862	3254	174	460	584.20	200.0	111.1	111.1	536	16	30	186
	03 B 380M	03 B 1500	3019	4800	251	420	685.80	292.0	166.7	166.7	610	23	50	431
390	01 B 390M	01 B 1600	1048	2071	116	460	546.10	140.0	76.2	76.2	512	10	23	95
400	01 B 400M	01 B 1600	1048	2071	116	460	546.10	140.0	76.2	76.2	512	10	23	95
	02 B 400M	02 B 1600	1948	3438	188	430	615.95	200.0	115.9	115.9	566	16	33	209
	03 B 400M	03 B 1600	3019	4800	251	420	685.80	292.0	166.7	166.7	610	23	50	431
420	01 B 420M	01 B 1700	1089	2218	121	430	571.50	140.0	76.2	76.2	538	10	22	104
	02 B 420M	02 B 1700	2069	3702	202	400	647.70	200.0	119.1	119.1	596	17	33	241
	03E B 420M	03E B 1700	3474	6006	276	360	700.00	284.0	160.0	160.0	640	23	42	395
440	01 B 440M	01 B 1800	1129	2366	127	410	596.90	140.0	76.2	76.2	562	10	22	114
	02 B 440M	02 B 1800	2195	4057	216	380	666.75	200.0	115.9	115.9	618	17	30	250
	03E B 440M	03E B 1700	3474	6006	276	360	700.00	284.0	160.0	160.0	640	23	42	395
460	01 B 460M	01 B 1800	1129	2366	127	410	596.90	140.0	76.2	76.2	562	10	22	114
	02 B 460M	02 B 1800	2195	4057	216	380	666.75	200.0	115.9	115.9	618	17	30	250
	03E B 460M	03E B 1800	3650	6156	302	340	740.00	294.0	170.0	170.0	680	24	46	431
	03X B 460M	03X B 1800	3771	6186	309	340	800.10	300.0	187.4	187.4	715	26	56	630

CARTRIDGE

References (1)	Principal Dimensions	Cartridge Only	Cartridge, Bearing and Seals	Principal Dimensions			Mass (kg)
				G (mm)	J (mm)	L (mm)	
01 C 20	01 BC 380MAT			571.50	98	280	126
02 C 41	02 BC 380MAT			647.70	146	342	209
03 C 68	03 BC 380MAT			774.70	202	438	399
01 C 21	01 BC 390MAT			603.30	102	286	141
01 C 21	01 BC 400MAT			603.30	102	286	141
02 C 42	02 BC 400MAT			685.80	146	350	254
03E C 68	03 BC 400MAT			774.70	202	438	399
01 C 22	01 BC 420MAT			628.70	102	298	150
02 C 43	02 BC 420MAT			717.60	146	356	264
03E C 89	03E BC 420MAT			788.00	200	442	408
01 C 23	01 BC 440MAT			650.90	108	310	151
02 C 44	02 BC 440MAT			733.40	146	356	265
03E C 89	03E BC 440MAT			788.00	200	442	408
01 C 23	01 BC 460MAT			650.90	108	310	151
02 C 44	02 BC 460MAT			733.40	146	356	265
03E C 90	03E BC 460MAT			840.00	200	450	454
03X C 71	03X BC 460MAT			914.40	235	482	740

1) Add 'EX' or 'GR' to reference for expansion type or fixed type respectively, eg:
 bearing: 01 B 420M EX
 cartridge: 01 C 22 EX
 bearing, cartridge and seals: 01 BC 420M EX AT
 complete unit: 01 BCP 420M EX AT
 Pillow blocks are common between expansion and fixed typed units.

2) Total available axial movement given. Maximum offset from centerline half this amount. 'Usual' axial movement denotes maximum recommended range of running positions of EX bearing for optimum performance. 'Maximum' axial movement denotes available movement before bearing strikes inside of standard Cooper cartridge.

4 BOLT

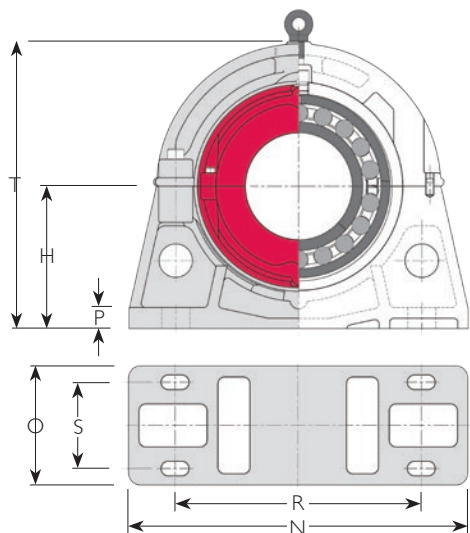

8 BOLT

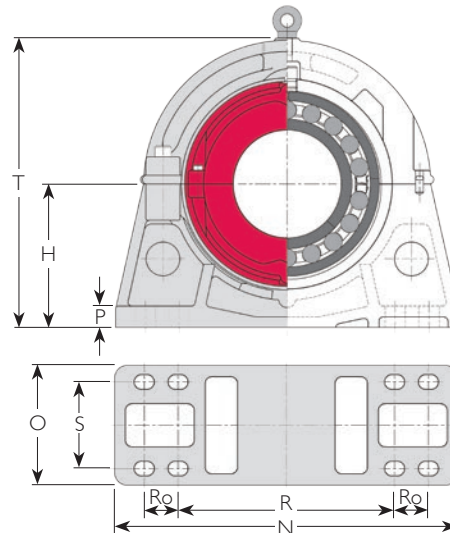

PILLOW BLOCK

References (I)		R					Bolts					Mass (kg)		Shaft Diameter d (mm)	
Pillow Block Only	Complete Unit	H (mm)	Min. (mm)	Max. (mm)	Ro (mm)	S (mm)	No.	Metric Size	Inch Size	N (mm)	O (mm)	P (mm)	T (mm)		Pillow Block Only (kg)
P20	01 BCP 380M AT	397	656	696	-	166	4	M36	1 1/2"	902	254	60	795	288	500
P41	02 BCP 380M AT	466	662	702	102	280	8	M36	1 1/2"	1092	368	67	925	445	840
P68	03 BCP 380M AT	559	780	832	115	292	8	M42	1 3/4"	1270	394	92	1120	859	1689
P21	01 BCP 390M AT	432	704	744	-	166	4	M36	1 1/2"	940	254	67	865	309	545
P21	01 BCP 400M AT	432	704	744	-	166	4	M36	1 1/2"	940	254	67	865	309	545
P42	02 BCP 400M AT	495	710	750	102	280	8	M36	1 1/2"	1168	368	70	990	537	1000
P68	03 BCP 400M AT	559	780	832	115	292	8	M42	1 3/4"	1270	394	92	1120	859	1689
P22	01 BCP 420M AT	445	736	776	-	166	4	M36	1 1/2"	966	254	67	890	316	570
P43	02 BCP 420M AT	514	748	788	102	280	8	M36	1 1/2"	1194	368	70	1030	564	1069
P89	03E BCP 420M AT	508	664	716	150	210	8	M48	2"	1270	360	90	1075	482	1285
P23	01 BCP 440M AT	464	768	808	-	190	4	M42	1 3/4"	1042	280	70	925	370	635
P44	02 BCP 440M AT	533	768	808	104	280	8	M36	1 1/2"	1244	368	73	1070	564	1079
P89	03E BCP 440M AT	508	664	716	150	210	8	M48	2"	1270	360	90	1075	482	1285
P23	01 BCP 460M AT	464	768	808	-	190	4	M42	1 3/4"	1042	280	70	925	370	635
P44	02 BCP 460M AT	533	768	808	104	280	8	M36	1 1/2"	1244	368	73	1070	564	1079
P90	03E BCP 460M AT	550	754	806	150	220	8	M48	2"	1370	380	95	1165	705	1590
P71	03X BCP 460M AT	660	908	960	178	362	8	M48	2"	1574	470	108	1320	1330	2700

3) Maximum fillet radii of abutments:
 inner race: 2.3mm
 outer race: 2mm

4) Refer to data on equivalent inch-size bearing for vibration data, screw data and lubrication details.

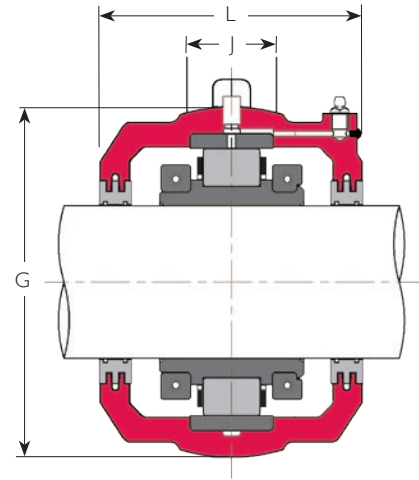
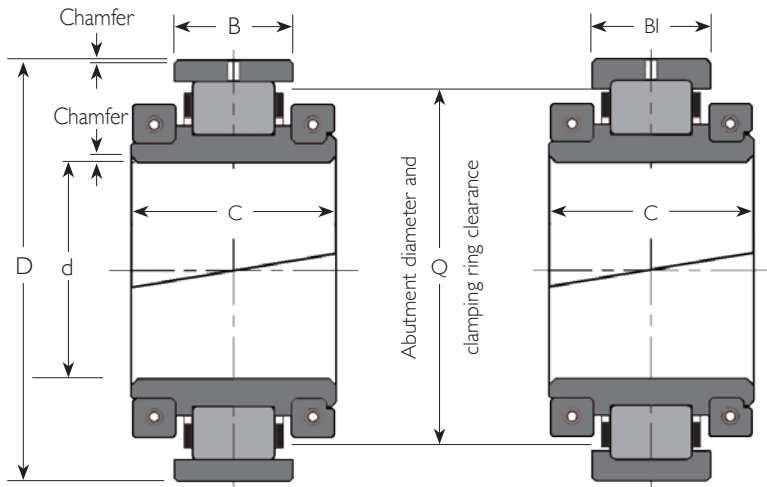

ROLLER BEARING

Shaft Dia. d (mm)	Reference (1)	Equivalent Inch-size Bearing (4)	Bearing Ratings				Principal Dimensions					Axial Movement (2)		
			Cr (kN)	Cor (kN)	Ca (kN)	Max. Speed (rpm)	D (mm)	C (mm)	B (mm)	BI (mm)	Q (mm)	Usual (mm)	Max. (mm)	Mass (kg)
480	01 B 480M	01 B 1900	1169	2433	133	380	628.65	144.0	81.0	81.0	594	11	24	128
	02 B 480M	02 B 1900	2313	4419	230	360	698.50	223.0	119.1	119.1	648	17	33	263
	03X B 480M	03X B 1800	3771	6186	309	340	800.10	300.0	187.4	187.4	715	26	56	630
500	01 B 500M	01 B 2000	1213	2593	138	360	654.05	168.0	80.2	80.2	618	11	23	136
	02 B 500M	02 B 2000	2430	4776	244	340	717.55	226.0	115.9	115.9	670	17	30	272
	03 B 500M	03 B 2000	4087	7042	347	310	850.90	300.0	187.4	187.4	765	26	56	730
530	01 B 530M	01 B 2100	1253	2755	141	340	692.15	168.0	81.0	81.0	650	11	23	164
	02 B 530M	02 B 2100	2658	5137	258	330	762.00	229.0	119.1	119.1	710	18	27	309
	03 B 530M	03 B 2000	4087	7042	347	310	850.90	300.0	187.4	187.4	765	26	56	730
560	01 B 560M	01 B 2200	1294	2916	142	330	717.55	168.0	81.0	81.0	675	11	23	178
	02 B 560M	02 B 2200	2790	5556	272	310	793.75	233.0	122.2	122.2	738	18	30	336
	03E B 560M	03E B 2200	4669	8511	383	280	863.60	310.0	196.9	196.9	800	28	56	635
580	01 B 580M	01 B 2300	1387	3138	144	310	749.30	172.0	84.1	84.1	706	11	25	195
	02 B 580M	02 B 2300	2336	4836	227	300	812.80	232.0	119.1	119.1	754	16	37	340
600	01 B 600M	01 B 2400	1431	3311	147	300	774.70	172.0	84.1	84.1	732	11	25	210
	02 B 600M	02 B 2400	2905	5992	300	290	838.20	214.0	119.1	119.1	786	18	27	381
	03E B 600M	03E B 2300	4887	9130	400	270	890.00	310.0	184.0	184.0	826	27	47	680

CARTRIDGE

References (1)	Principal Dimensions	References (1)				Principal Dimensions			
		Cartridge Only	Cartridge, Bearing and Seals	G (mm)	J (mm)	L (mm)	Mass (kg)		
01 C 24	01 BC 480M AT	682.60	108	324	162				
02 C 45	02 BC 480M AT	762.00	146	374	272				
03X C 71	03X BC 480M AT	914.40	235	482	740				
01 C 25	01 BC 500M AT	717.60	114	330	192				
02 C 46	02 BC 500M AT	787.40	146	374	323				
03 C 94	03 BC 500M AT	958.90	204	508	770				
01 C 26	01 BC 530M AT	755.70	114	336	226				
02 C 47	02 BC 530M AT	831.90	150	374	351				
03 C 94	03 BC 530M AT	958.90	204	508	770				
01 C 27	01 BC 560M AT	781.10	114	342	252				
02 C 48	02 BC 560M AT	866.80	152	380	379				
03E C 94	03E BC 560M AT	958.90	204	490	671				
01 C 28	01 BC 580M AT	816.00	120	348	273				
02 C 49	02 BC 580M AT	882.70	152	380	386				
01 C 29	01 BC 600M AT	841.40	120	348	290				
02 C 50	02 BC 600M AT	914.40	152	394	454				
03E C 95	03E BC 600M AT	990.00	204	490	720				

1) Add 'EX' or 'GR' to reference for expansion type or fixed type respectively, eg:
 bearing: 01 B 480M EX
 cartridge: 01 C 24 EX
 bearing, cartridge and seals: 01 BC 480M EX AT
 complete unit: 01 BCP 480M EX AT
 Pillow blocks are common between expansion and fixed typed units.

2) Total available axial movement given. Maximum offset from centerline half this amount. 'Usual' axial movement denotes maximum recommended range of running positions of EX bearing for optimum performance. 'Maximum' axial movement denotes available movement before bearing strikes inside of standard Cooper cartridge.

4 BOLT

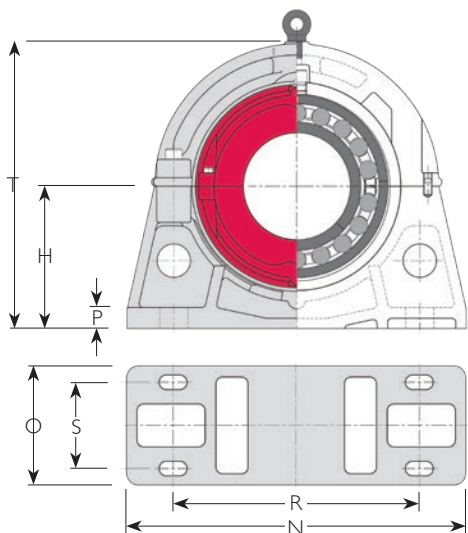

8 BOLT

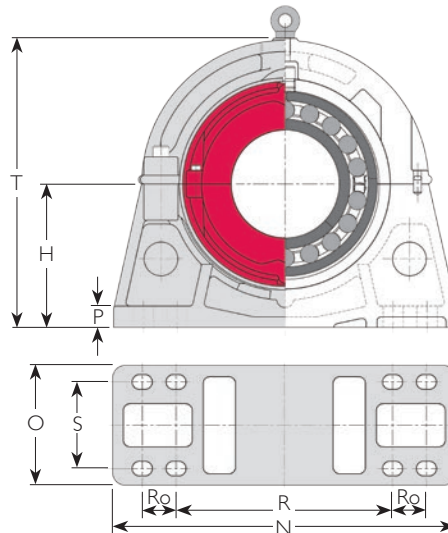

PILLOW BLOCK

References (I)		R					Bolts						Mass (kg)		Shaft Diameter d (mm)
Pillow Block Only	Complete Unit	H (mm)	Min. (mm)	Max. (mm)	Ro (mm)	S (mm)	No.	Metric Size	Inch Size	N (mm)	O (mm)	P (mm)	T (mm)	Pillow Block Only (kg)	
P24	01 BCP 480M AT	483	796	836	-	188	4	M42	1 3/4"	1092	304	73	965	402	692
P45	02 BCP 480M AT	552	792	832	115	280	8	M36	1 1/2"	1270	368	76	1110	690	1225
P71	03X BCP 480M AT	660	908	960	178	362	8	M48	2"	1574	470	108	1320	1330	2700
P25	01 BCP 500M AT	489	824	864	-	216	4	M42	1 3/4"	1092	304	76	980	402	730
P46	02 BCP 500M AT	572	824	864	115	280	8	M36	1 1/2"	1296	368	80	1145	677	1272
P94	03 BCP 500M AT	622	914	966	165	242	8	M56	2 1/4"	1600	406	102	1340	1000	2500
P26	01 BCP 530M AT	533	884	924	-	206	4	M42	1 3/4"	1194	304	80	1065	495	885
P47	02 BCP 530M AT	591	870	910	114	280	8	M36	1 1/2"	1398	368	83	1180	905	1565
P94	03 BCP 530M AT	622	914	966	165	242	8	M56	2 1/4"	1600	406	102	1340	1000	2500
P27	01 BCP 560M AT	552	916	956	-	206	4	M42	1 3/4"	1220	304	83	1110	570	1000
P48	02 BCP 560M AT	616	904	956	114	280	8	M42	1 3/4"	1422	382	86	1230	965	1680
P94	03E BCP 560M AT	622	914	966	165	242	8	M56	2 1/4"	1600	406	102	1340	1000	2306
P28	01 BCP 580M AT	578	857	896	102	220	8	M36	1 1/2"	1346	304	90	1156	630	1098
P49	02 BCP 580M AT	635	932	984	115	280	8	M42	1 3/4"	1448	382	90	1270	1000	1726
P29	01 BCP 600M AT	597	888	928	105	220	8	M36	1 1/2"	1372	304	90	1200	630	1130
P50	02 BCP 600M AT	673	984	1036	114	280	8	M42	1 3/4"	1524	382	92	1345	1050	1885
P95	03E BCP 600M AT	622	914	966	165	242	8	M56	2 1/4"	1600	406	102	1340	930	2330

3) Maximum fillet radii of abutments:
 inner race: 2.3mm
 outer race: 2mm

4) Refer to data on equivalent inch-size bearing for vibration data, screw data and lubrication details.

MARINE SPECIFICATION PILLOW BLOCKS

As well as the standard specification pillow blocks, Cooper manufacture a range of pillow blocks with additional features intended to aid their application to marine drive systems. These additional features comprise:

- 'Solid' base (without lightening cores to the underside) to provide a large surface area for use with chocking compound
- Jacking screw holes to aid initial height adjustment (usually before application of chocking compound)
- Lubrication of the spherical seat, to allow changing alignment of the shaft and pillow block in service

All of these features can be included on any size of pillow block either individually or in combination, but on the range of pillow blocks shown in the table on the next page they are all included as standard. For other sizes of pillow block, or if only certain features are required, please contact our technical department for relevant part codes.

These 'marine specification' pillow blocks may be used in place of standard pillow blocks as shown in the table. It is possible to

mount any combination of bearing and cartridge which would usually be mounted in the standard pillow block in the equivalent marine specification pillow block.

Pillow blocks of the Z Series (e.g. Z06) have the same bolt hole spacings, footprint dimensions and centerline heights as the equivalent standard pillow blocks. The dimensions of other pillow blocks in the table may differ from the standard pillow blocks, and the references for standard pillow blocks are only to indicate bearing and cartridge compatibility.

Pillow blocks may also feature drillings for temperature elements. Provision for temperature elements (when specified) is usually made by a suitable hole in the cartridge only, with the probe inserted axially. However, when there is insufficient space for an axially oriented probe, a radial orientation is possible. The temperature probe is then mounted on the pillow block cap, with corresponding drillings through the pillow block and cartridge. Please consult our technical department for details.

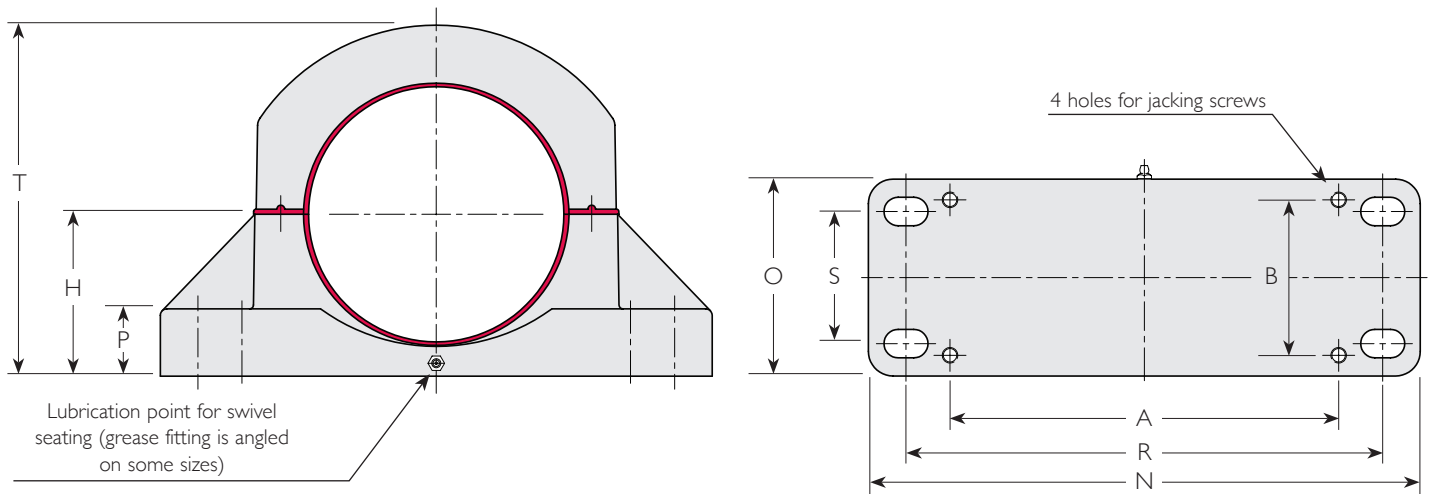

Reference	Equivalent Standard Pillow Block	H (in)	R		S (mm)	Metric Size	Inch Size	A (in)	B (in)	Jacking Screw Size	N (in)	O (in)	P (in)	T (in)
			Min. (in)	Max. (in)										
Z06	P06 or P0613	4 15/16	14	15	4	M20	3/4"	11 13/16	4 3/4	M12	16 3/4	6	2	10 3/4
Z07	P07 or P0710	5 5/8	15 3/4	16 11/16	4 1/2	M20	3/4"	13 3/8	5 1/8	M12	18 3/4	6 3/4	2 3/8	12 3/8
Z08	P08	6 3/8	17 1/4	18 3/16	4 3/4	M24	7/8"	13 3/8	5 7/8	M12	20	7	1 1/2	14 3/4
Z09	P09	7 1/8	18 1/2	19 1/2	4 3/4	M24	7/8"	15 11/16	5 1/16	M12	22	7	1 5/8	15 15/16
Z10	P10	7 1/8	19	20	4 3/4	M24	7/8"	16 5/16	5 1/2	M12	22	7	1 5/8	16 15/16
PI019	P10 (1)	8 9/32	19 5/16 (2)		5 1/16	M30	-	12 3/16	6 5/16	M12	22 1/16	7 1/2	1 3/4	17 3/8
PI031	P10 (1)	8 9/32	19 5/16 (2)		5 1/16	M30	-	12 3/16	6 5/16	M12	22 1/16	7 1/2	2 15/16	17 1/2
Z11	P11	8 3/8	14	15	4 3/4	M24	1"	17 5/16	5 1/2	M12	20	7	1 5/8	16 15/16
Z30	P30	8	21	22	4 3/4	M24	1"	17 11/16	5 1/2	M12	24	7	2	18 1/8
Z31	P31	8 1/4	21 1/2	22 1/2	5	M24	1"	17 11/16	5 15/16	M12	25	8	2	18 1/2
P3115	P31 (1)	9 1/16	22 5/8 (2)		9 7/16	M30	-	15 3/4	10 13/16	M12	27	13	2 3/4	19 3/4
Z32	P32	10 1/2	16 7/8	18 3/8	6 3/4	M30	1 1/4"	14 3/16	7 1/16	M12	23 1/2	9 1/2	1 3/4	21 1/16
P3311	P33 (1)	9 1/16	22 5/8 (2)		9 7/16	M30		15 3/4	10 13/16	M12	27	13	2 3/4	19 3/4
Z33	P33	10 3/4	17 1/4	18 3/4	6 1/2	M30	1 1/4"	21 5/8	6 11/16	M12	25	9 1/2	1 3/4	21 7/16
P3419	P34 (3)	12	20 (2)		7 1/2	M30	1 1/4"				27	10 1/2	2	24

- 1) Dimensions differ
- 2) Nominal centers of drilled bolt holes. (Other sizes have slots)
- 3) Dimensions as P3419, except that P3419 has drilled base bolt holes rather than slots

SAFC500, SNC500 AND SDC3100

Cooper SAFC500, SNC500 and SDC3100 Series pillow blocks are designed for use where interchangeability with SAF500, SN500 and SD3100 Series pillow block units is required, respectively. They may be used to economically replace existing solid bearings, or may be incorporated into new machinery where the envelope dimensions of these units are desirable.

The Cooper pillow blocks have bolt hole spacings and heights to centers corresponding to the equivalent industry standard units for solid bearings. However the footprint, overall pillow block height and length on shaft may differ and should be checked against the available space.

Cooper SAFC500, SNC500 and SDC3100 pillow blocks are designed to incorporate Cooper bearings housed in cartridges (refer to page 34), which gives these units the benefit of superior Cooper sealing and the option of many different seal types.

The tables on the following pages list the Cooper pillow blocks with the bearing and cartridge unit of the same bore size as the solid bearing that is commonly found mounted in the equivalent pillow block unit on a parallel shaft with an adaptor sleeve. These pillow blocks may also be used with alternative sizes of Cooper bearing. Where the bearing and cartridge unit listed with the Cooper pillow block on the following pages is used in the same size of standard Cooper pillow block as another size of Cooper

bearing and cartridge, generally this alternative size of bearing and cartridge can be used in the same Cooper SAFC500, SNC500 or SDC3100 Series pillow block.

For example:

01E BC SAFC513 203 incorporates an 01E B 203 bearing and an 01 C 03 cartridge.

01 C 03 is usually housed in a P03 pillow block (by reference to pages 36 and 37).

Other bearings and cartridges are also housed in P03 pillow blocks, including: 100 C 03 and 02 C 03. These can alternatively be housed in a Cooper SAFC513 pillow block.

SNC500 pillow blocks are manufactured from gray iron as standard. SAFC500 and SDC3100 pillow blocks are manufactured from ductile iron as standard.

The permissible loading on these pillow blocks is as for standard gray iron pillow blocks, as described on page 35. Where special dispensation to load outside the envelope specified on page 35 has been given for standard pillow blocks, this does not necessarily apply to SAFC500, SNC500 or SDC3100 Series pillow blocks. Please consult our technical department if other loading conditions are required to be met.

TYPE E COMPATIBLE PILLOW BLOCKS

Conversion from solid bearings to Cooper split-to-the-shaft roller bearings is easy. In the table below, base-to-bearing centerline

heights and bolt hole spacing conform to common industry standard Type E sizes and are available in 2-bolt and 4-bolt pedestals.

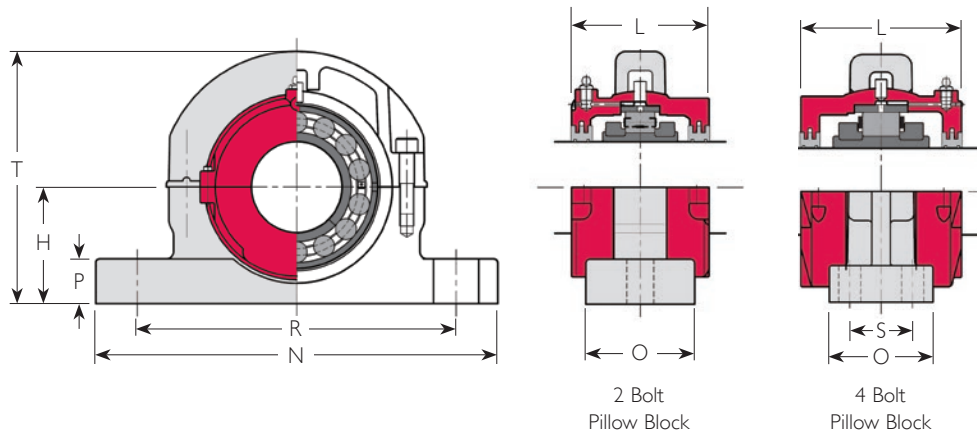

Shaft Diameter d (in)	References			R			S (in)	Bolts							Mass (lb)	
	Bearing (1)	Pillow Block Only	Complete Unit (2)	H (in)	Min.	Max.		No.	Size	N (in)	O (in)	P (in)	T (in)	L (in)	Pillow Block Only	Complete Unit
3 7/16	01E B 307	SAFC51810	01E BCPNE 307 AT	3 3/4	10 1/4	11 5/8	-	2	3/4	13 5/8	3 7/8	1 1/4	9 1/2	5 5/16	30	55
3 15/16	01E B 315	PN0624	01E BC4PNE 315 AT	4 1/4	12 1/4	12 3/4	2 1/4	4	3/4	15 3/8	4 1/2	1 3/16	10	5 1/4	36	67
4 7/16	01 B 407	PN0719 (3)	01 BC4PNE 407 AT	4 3/4	13 1/4	13 3/4	2 1/2	4	3/4	16 1/2	4 5/8	1 1/4	11 1/2	5 5/8	44	90

1) For full references of bearings and cartridges, see pages 38 to 43.

2) Add 'EX' or 'GR' to reference for expansion type or fixed type respectively, e.g.: 01E BCPNE 307 GR AT

3) Special cartridge required for this size.

References: Fixed-type cartridge (for TL seals): 01C7GR28
Expansion-type cartridge (for TL seals): 01C7EX32

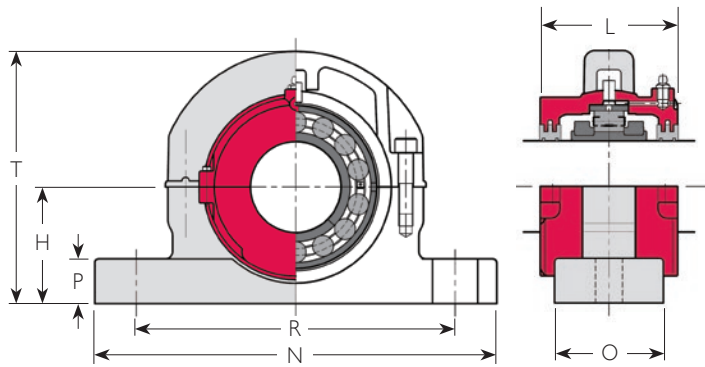
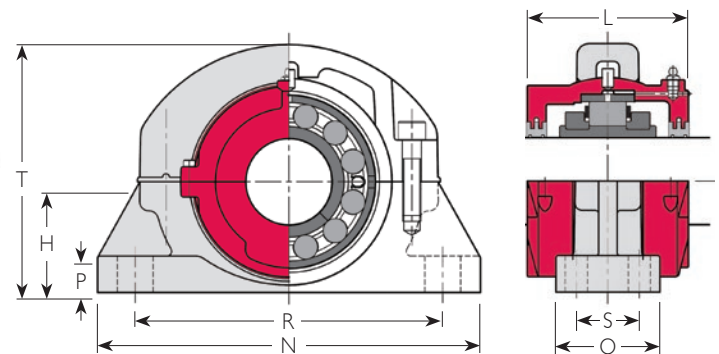
2 BOLT SAFC**4 BOLT SAFC**

Shaft Diameter d (in)	References		R		H (in)	Bolts		Mass (lb)							
	Bearing (1)	Pillow Block Only Complete Unit (2)	Min.	Max.		S (in)	No.	Size	N (in)	O (in)	P (in)	T (in)	L (in)	Pillow Block Only	Complete Unit
1 15/16	01E B 115	SAFC511 01E BCSAFC511 115 AT	7 3/8	7 7/8	2 3/4	-	2	5/8	9 5/8	2 3/4	7/8	6 1/8	3 13/16	9.5	18.3
2 3/16	01E B 203	SAFC513 01E BCSAFC513 203 AT	8 1/8	9 1/2	3	-	2	5/8	11	3 1/8	1	7	4 1/16	14.1	25.1
2 7/16	01E B 207	SAFC515 01E BCSAFC515 207 AT	8 5/8	9 5/8	3 1/4	-	2	5/8	11 1/4	3 1/8	1 1/8	7 1/4	4 1/16	16.3	27.3
2 11/16	01E B 211	SAFC516 01E BCSAFC516 211 AT	9 5/8	11	3 1/2	-	2	3/4	13	3 1/2	1 3/16	7 7/8	4 1/2	21.4	39
2 15/16	01E B 215	SAFC517 01E BCSAFC517 215 AT	9 7/8	11	3 3/4	-	2	3/4	13	3 1/2	1 7/16	8 1/8	4 1/2	25.4	43
	02 B 215	FS AFC517 02 BCFS AFC517 215 AT	10	10 7/8	3 3/4	2 1/8	4	5/8	13	3 1/2	1 1/4	8 1/2	5 1/2	25.4	56
3 3/16	01E B 303	SAFC518 01E BCSAFC518 303 AT	10 3/8	11 5/8	4	-	2	3/4	13 3/8	3 7/8	1 1/4	9 1/2	5 5/16	34	58
3 7/16	01E B 307	SAFC520 01E BCSAFC520 307 AT	11 5/8	13 1/8	4 1/2	-	2	7/8	15 1/4	3 7/8	1 3/4	10	5 5/16	43	67
	02 B 307	FS AFC520 02 BCFS AFC520 307 AT	11 5/8	13 1/8	4 1/2	2 3/8	4	3/4	15 1/4	4 3/8	1 3/4	10 1/4	6 1/16	33	71
3 15/16	02 B 315	SAFC522 02 BCSAFC522 315 AT	12 5/8	14 1/2	4 15/16	2 3/4	4	3/4	16 1/2	4 3/4	2	11 5/8	5 3/4	43	89
4 7/16	02 B 407	SAFC526 02 BCSAFC526 407 AT	14 5/8	16	6	3 1/4	4	7/8	18 3/8	5 1/8	2 3/8	14 1/4	6 3/8	95	172
4 15/16	02 B 415 (3)	SAFC528 (3) 02 BCSAFC528 415 AT	16	17 1/8	6	3 3/8	4	1	20 1/8	5 7/8	1 3/8	15	7 1/4	119	220
5 7/16	02 B 507	SAFC532 02 BCSAFC532 507 AT	17 3/8	19 1/4	6 11/16	3 3/4	4	1	22	6 1/4	2 11/16	16 3/4	7 3/8	163	288
5 15/16	02 B 515	SAFC534 02 BCSAFC534 515 AT	19 3/8	21 5/8	7 1/16	4 1/4	4	1	24 3/4	6 3/4	2 3/4	17 1/4	8	183	332

1) For full references of bearings and cartridges see pages 36 to 44.

2) Add 'EX' or 'GR' to reference for expansion type or fixed type respectively, e.g.: 01E BCSAFC511 115 EX AT

3) Special bearing and cartridge required for this size. Bearing ratings are as for standard 02 B 415, but outside diameters of bearing and cartridge differ from standard.

References: Fixed-type bearing: 02 B 415 GR 16
 Expansion-type bearing: 02 B 415 EX 16
 Fixed-type cartridge (for TL seals): 02 C 10 GR 21
 Expansion-type cartridge (for TL seals): 02 C 10 EX 21

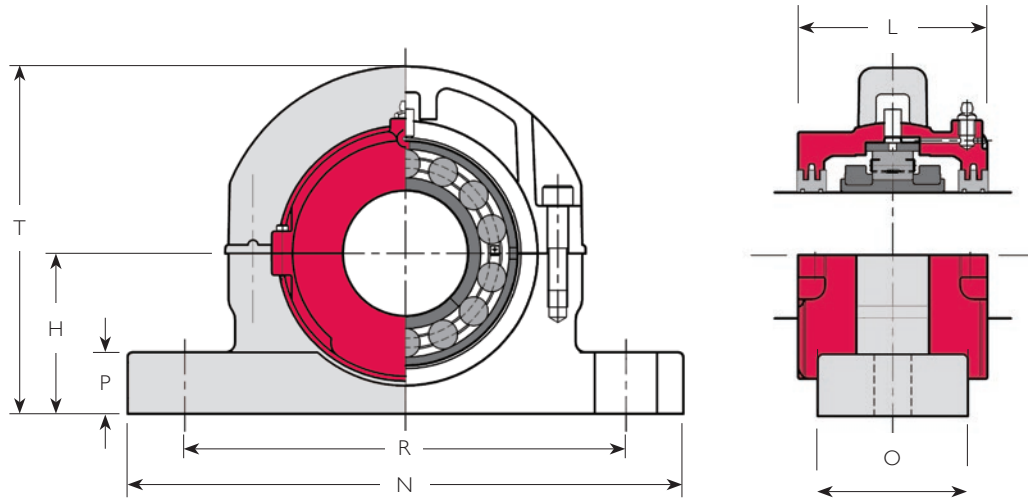

Shaft Diameter d (mm)	References			H (mm)	R		Bolt Size	N (mm)	O (mm)	P (mm)	T (mm)	L (mm)	Mass (kg)	
	Bearing (1)	Pillow Block Only	Complete Unit (2)		Min. (mm)	Max. (mm)							Pillow Block Only	Complete Unit
60	01E B 60M	SNC513	01E BCSNC513 60M AT	80	226	242	M16	280	70	32	180	104	4.9	9.9
65	01E B 65M	SNC515	01E BCSNC515 65M AT	80	226	242	M16	280	70	32	180	104	4.9	9.9
70	01E B 70M	SNC516	01E BCSNC516 70M AT	95	254	266	M20	315	90	38	208	114	7.3	15.3
75	01E B 75M	SNC517	01E BCSNC517 75M AT	95	254	266	M20	315	90	38	208	114	7.3	15.3
80	01E B 80M	SNC518	01E BCSNC518 80M AT	100	284	296	M20	345	100	32	240	136	13.4	24.4
85	01E B 85M	SNC519	01E BCSNC519 85M AT	112	284	296	M20	345	100	44	252	136	15.2	26.2
90	01E B 90M	SNC520	01E BCSNC520 90M AT	112	312	328	M24	380	90	44	252	136	13.3	24.3
100	01E B 100M	SNC522	01E BCSNC522 100M AT	125	342	366	M24	420	102	52	272	134	14.7	28.7
110	01 B 110M	SNC524	01E BCSNC524 110M AT	140	344	356	M24	410	120	45	310	142	19.5	41.6
115	01 B 115M	SNC526	01E BCSNC526 115M AT	150	372	388	M24	450	130	50	320	142	22.7	44.8
125	01 B 125M	SNC528	01E BCSNC528 125M AT	150	414	426	M30	500	150	50	360	156	38.2	70.5
135	01 B 135M	SNC530	01E BCSNC530 135M AT	160	444	456	M30	530	160	56	386	168	40	75.8
140	01 B 140M	SNC532	01E BCSNC532 140M AT	170	462	478	M30	558	178	41	391	168	52	87.8

1) For full references of bearings and cartridges see pages 54 to 60.

2) Add 'EX' or 'GR' to reference for expansion type or fixed type respectively, e.g.: 01 BCSDC3134 150M EX AT

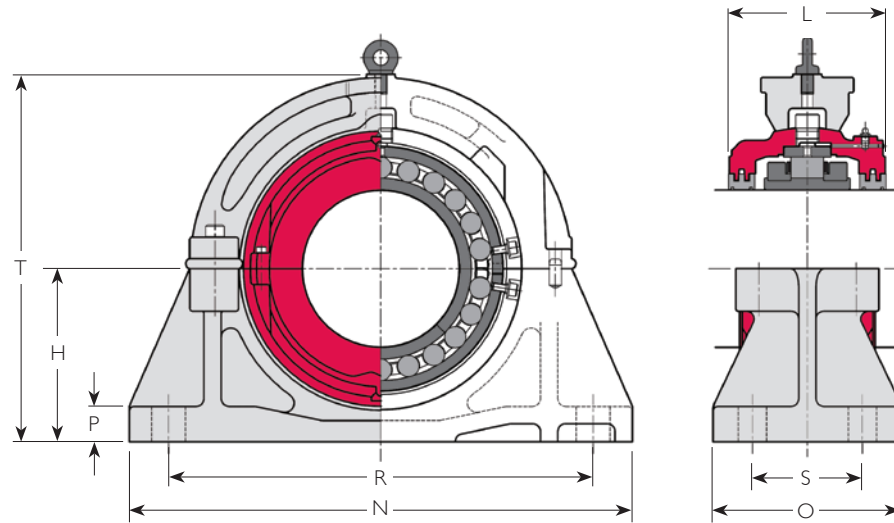

Shaft Diameter d (mm)	References				R			Mass (kg)								
	Bearing Expansion/ Fixed	Cartridge Expansion/ Fixed	Pillow Block Only	Complete Unit Expansion/ Fixed	H (mm)	Min. (mm)	Max. (mm)	S (mm)	Bolt Size	N (mm)	O (mm)	P (mm)	T (mm)	L (mm)	Pillow Block Only	Complete Unit
150	01 B 150M EX	01C 10 EX	SDC3134	01 BCSDC3134 150M EX AT	170	424	436	100	M24	510	178	40	401	174	48	98
	01 B 150M GR	01C 10 GR		01 BCSDC3134 150M GR AT												
	02 B 150M EX10	02C 31 EX20	PN3112	02 BCSDC3134 150M EX AT												
	02 B 150M GR11	02C 31 GR22		02 BCSDC3134 150M GR AT												
160	01E B 160M EX	01C 11 EX	SDC3136	01E BCSDC3136 160M EX AT	180	438	462	110	M24	530	190	40	396	192	50	105
	01E B 160M GR	01C 11 GR		01E BCSDC3136 160M GR AT												
	02 B 600-160M EX	02C 31 EX OTL	PN3113	02 BCSDC3136 600-160M EX AT												
	02 B 600-160M GR	02C 31 GR OTL		02 BCSDC3136 600-160M GR AT												
170	01E B 170M EX	01C 12 EX	SDC3138	01E BCSDC3138 170M EX AT	190	468	492	120	M24	560	200	40	425	200	59	113
	01E B 170M GR	01C 12 GR		01E BCSDC3138 170M GR AT												
	02E B 170M EX10	02C 32 EX11	PN3210	02E BCSDC3138 170M EX AT												
	02E B 170M GR13	02C 32 GR13		02E BCSDC3138 170M GR AT												
180	01E B 180M EX	01C 12 EX	SDC3140	01E BCSDC3140 180M EX AT	210	503	517	130	M30	600	210	40	445	200	66	120
	01E B 180M GR	01C 12 GR		01E BCSDC3140 180M GR AT												
	02E B 180M EX	02C 33 EX	PN3312	02E BCSDC3140 180M EX AT												
	02E B 180M GR	02C 33 GR		02E BCSDC3140 180M GR AT												
200	01E B 200M EX	01C 13 EX	SDC3144	01E BCSDC3144 200M EX AT	220	533	547	140	M30	640	240	45	467	200	87	153
	01E B 200M GR	01C 13 GR		01E BCSDC3144 200M GR AT												
	02E B 200M EX	02C 34 EX10	PN3410	02E BCSDC3144 200M EX AT												
	02E B 200M GR	02C 34 GR15		02E BCSDC3144 200M GR AT												

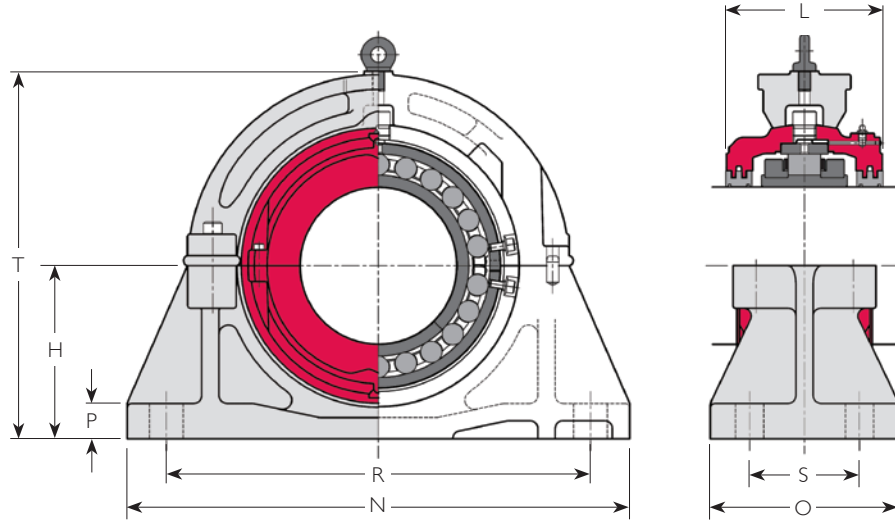

Shaft Diameter d (mm)	References				R		Mass (kg)									
	Bearing Expansion/ Fixed	Cartridge Expansion/ Fixed	Pillow Block Only	Complete Unit Expansion/Fixed	H (mm)	Min. (mm)	Max. (mm)	S (mm)	Bolt Size	N (mm)	O (mm)	P (mm)	T (mm)	L (mm)	Pillow Block Only	Complete Unit
220	01 E B 220M EX	01C 14 EX	SDC3148	01E BCSDC3148 220M EX AT	240	593	607	150	M30	700	250	45	510	216	96	174
	01 E B 220M GR	01C 14 GR		01E BCSDC3148 220M GR AT												
	02E B 220M EX	02C 35 EX	PN3510	02E BCSDC3148 220M EX AT												
	02E B 220M GR	02C 35 GR		02E BCSDC3148 220M GR AT												
240	01E B 240M EX	01C 15 EX	SDC3152	01E BCSDC3152 240M EX AT	260	642	658	160	M36	770	280	49	552	222	132	230
	01E B 240M GR	01C 15 GR		01E BCSDC3152 240M GR AT												
	02E B 240M EX	02C 36 EX	PN3610	02E BCSDC3152 240M EX AT												
	02E B 240M GR	02C 36 GR		02E BCSDC3152 240M GR AT												
260	01E B 260M EX	01C 16 EX	SDC3156	01E BCSDC3156 260M EX AT	280	662	678	160	M36	790	280	55	591	232	160	280
	01E B 260M GR	01C 16 GR		01E BCSDC3156 260M GR AT												
	02E B 260M EX	02C 36 EX10	PN3612	02E BCSDC3156 260M EX AT												
	02E B 260M GR	02C 36 GR11		02E BCSDC3156 260M GR AT												
280	01E B 280M EX	01C 16 EX	SDC3160	01E BCSDC3160 280M EX AT	300	702	718	190	M36	830	310	55	611	232	175	295
	01E B 280M GR	01C 16 GR		01E BCSDC3160 280M GR AT												
	02E B 280M EX	02C 37 EX	PN3711	02E BCSDC3160 280M EX AT												
	02E B 280M GR	02C 37 GR		02E BCSDC3160 280M GR AT												
300	01E B 300M EX	01C 17 EX	SDC3164	01E BCSDC3164 300M EX AT	320	742	758	200	M36	880	320	60	663	248	208	354
	01E B 300M GR	01C 17 GR		01E BCSDC3164 300M GR AT												
	02E B 300M EX	02C 38 EX	PN3811	02E BCSDC3164 300M EX AT												
	02E B 300M GR	02C 38 GR		02E BCSDC3164 300M GR AT												



COOPER QUICK-CHANGE PEDESTALS

New Cooper Quick-Change pedestals make it easier than ever to replace a solid bearing... and eliminate much of the downtime (and cost) typically required for installation.

Like other Cooper bearings and pedestals, Quick-Change pedestals are split into two halves for easy assembly around a fixed shaft. But thanks to an innovative angled design, the bottom half of these pedestals slides easily under the shaft (even one with low clearance), with no need for a jack or hoist.

Cooper Quick-Change pedestals are ideal solutions for fans and other applications in a wide range of industries (mining, marine, steel, power generation, etc.). They typically use standard Cooper 01, 01E, 02, or 02E bearings and feature the same superior sealing options available with other Cooper products.

This new angled design — available for years as a custom solution but now a Cooper standard — is the latest innovation from

Cooper Bearings, the global leader in split roller bearings for over 100 years.

Cooper Quick-Change pedestals are designed to replace solid bearings mounted on adapter sleeves in industry-standard housings and are interchangeable with other Cooper pedestals. All have bolt-hole spacings and heights-to-center that correspond to equivalent industry standards for solid bearings. However, the footprint, pedestal height and length on shaft may differ and should be checked against the available space.

Most applications use standard Cooper bearings. However, in some cases cartridges and bearings should have a smaller outside diameter to assure adequate thickness of the pedestal base. This does not affect the load ratings, which will match those of standard bearings of the same bore size.

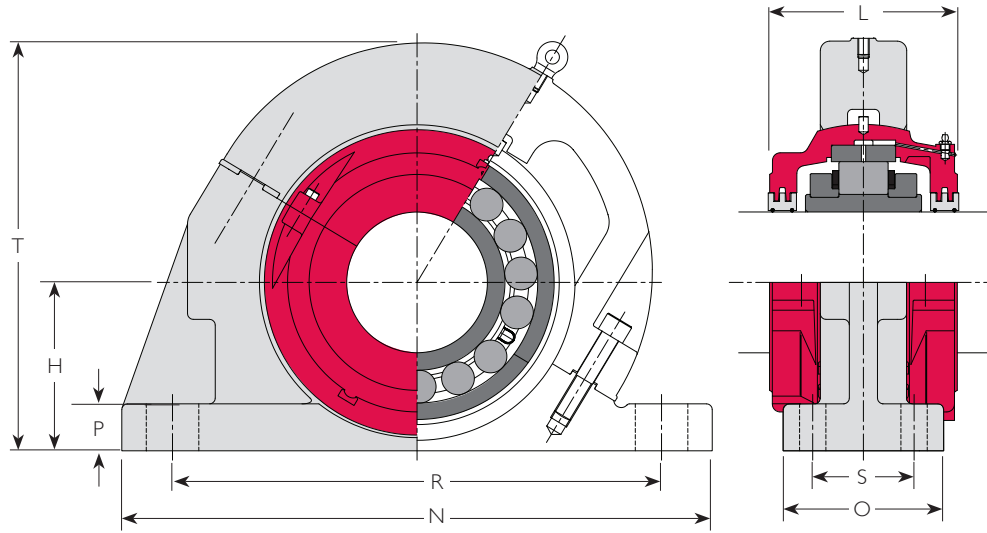

Shaft Diameter (2) (mm)	Bearing Reference (1)	Reference (1) (Pedestal Only)	H (mm)	R		S (mm)	Bolts No.	Size	N (mm)	O (mm)	P (mm)	T (mm)	L (mm)	LI (mm)	Pedestal Mass (kg)
				Min (mm)	Max (mm)										
50	01E B 50M	SNQ511	70	203	219	-	2	M16	255	60	25	158	98	98	3.9
75	01E B 75M	SNQ517	95	254	280	-	2	M20	315	90	38	208	114	114	9.7
90	01E B 90M	SNQ520	112	312	328	-	2	M24	380	90	44	253	136	136	17.5
100	01E B 100M	SNQ522	125	342	366	-	2	M24	420	102	52	274	134	134	21.7
110	01 B 110M	SNQ524	140	344	356	-	2	M24	410	120	45	310	142	142	26.1
115	01 B 115M	SNQ526	150	372	388	-	2	M24	450	130	50	320	142	142	33.3
125	01 B 125M	SNQ528	150	414	426	-	2	M30	500	150	38	358	156	156	42.9
135	01 B 135M	SNQ530	160	444	456	-	2	M30	530	160	45	380	168	168	52.8
140	01 B 140M	SNQ532	170	462	478	-	2	M30	558	178	41	390	168	168	59.7
150	01 B 150M	SDQ3134	170	424	436	100	4	M24	510	178	38	399	174	174	55.9
160	01E B 160M	SDQ3136	180	438	462	110	4	M24	530	190	40	393	172	192	56.8
180	01E B 180M	SDQ3140	210	503	517	130	4	M30	600	210	40	442	172	200	77.9
200	01E B 200M	SDQ3144	220	533	547	140	4	M30	640	240	45	463	172	200	99.4
220	01E B 220M	SDQ3148	240	593	607	150	4	M30	700	250	45	507	178	216	112.6

Shaft Diameter (2) (in)	Bearing Reference (1)	Reference (1) (Pedestal Only)	H (in)	R		S (in)	Bolts No.	Size	N (in)	O (in)	P (in)	T (in)	L (in)	LI (in)	Pedestal Mass (lbs)
				Min (in)	Max (in)										
2 3/16	01E B 203	SAFQ513	3	8 1/8	9 1/2	-	2	5/8	11	3 1/8	1	7	4 1/16	4 1/16	12.8
2 11/16	01E B 211	SAFQ516	3 1/2	9 5/8	11	-	2	3/4	13	3 1/2	1 3/16	7 7/8	4 1/2	4 1/2	18.3
2 15/16	02 B 215	FSAFQ517	3 3/4	10	10 7/8	2 3/16	4	5/8	13	3 1/2	1	9 5/16	5 1/2	5 1/2	25.8
3 7/16	02 B 307	FSAFQ520	4 1/2	11 5/8	13 1/8	2 3/8	4	3/4	15 1/4	4 3/8	1 3/4	10 3/8	6 1/16	6 1/16	39.9
3 15/16	02 B 315	SAFQ522	4 15/16	12 5/8	14 1/2	2 3/4	4	3/4	16 1/2	4 3/4	1 9/16	11 5/8	5 3/4	5 3/4	50.5
4 7/16	02 B 407	SAFQ526	6	14 7/8	16	3 1/4	4	7/8	18 3/8	5 1/8	2 3/8	12 15/16	6 3/8	6 3/8	76.3
4 15/16	02 B 415 (3)	SAFQ528 (3)	6	16	17 1/8	3 3/8	4	1	20 1/8	5 7/8	1 3/8	13 7/8	7 1/4	7 1/4	90.2
5 7/16	02 B 507	SAFQ532	6 11/16	17 3/8	19 1/4	3 3/4	4	1	22	6 1/4	2	15 3/4	7 3/8	7 3/8	113.8
5 15/16	02 B 515	SAFQ534	7 1/16	19 3/8	21 5/8	4 1/4	4	1	24 3/4	6 3/4	2	17 1/8	8	8	170.5

- 1) For full references of bearings and cartridges, see pages 36 to 44 and 54 to 64.
- 2) Shaft diameters shown are the most common. Alternative sizes in the same group are available.
- 3) Special bearing and cartridge required for this size. Bearing ratings are as for standard 02 B 415, but outside diameters of the bearing and cartridge differ from standard.

References: Fixed-type bearing: 02 B 415 GR 16
 Expansion-type bearing: 02 B 415 EX 16
 Fixed-type cartridge (for TL seals): 02 C 10 GR 21
 Expansion-type cartridge (for TL seals): 02 C 10 EX 21

Flanges provide a simple means of mounting Cooper split roller bearings against a vertical or horizontal face or bulkhead.

The bearings are housed in standard Cooper cartridges (refer to page 34).

The top halves of both flange and cartridge can be lifted for inspection once installed (provided that the shaft can be maintained safely in position).

The sizes listed on the following pages are the standard sizes that are manufactured regularly. As with other Cooper housings, particulars of alternative versions or sizes not listed can be supplied on request.

The most common type of flange is the round flange as illustrated below and listed on pages 86 to 99. These flanges are manufactured from gray iron as standard. Ductile iron and steel flanges are also available.

ROUND FLANGE

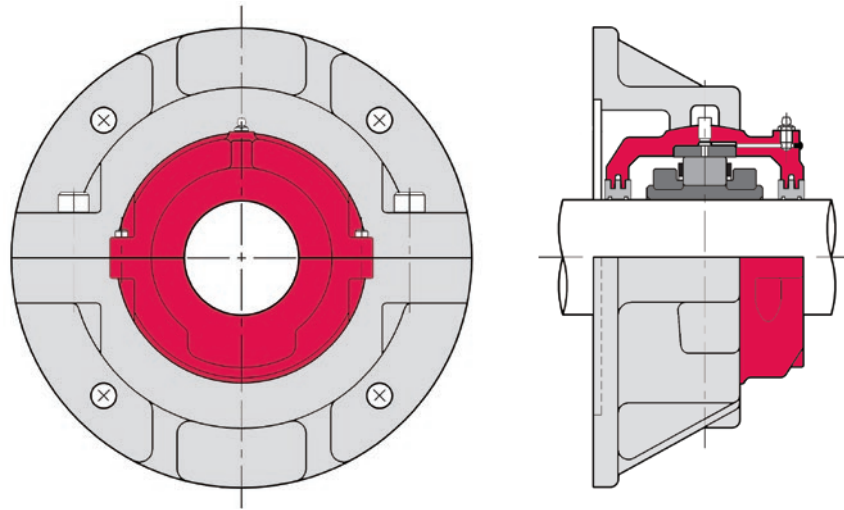

For bearings from 1 1/16" to 3 7/16" / 45mm to 85mm shaft size, a more compact alternative is the square ('DF line') flange as illustrated below and listed on pages 100 to 101.

Square flanges are manufactured from ductile iron as standard and are ideal for use on steel frames or skid mounted equipment.

SQUARE (DF) FLANGE

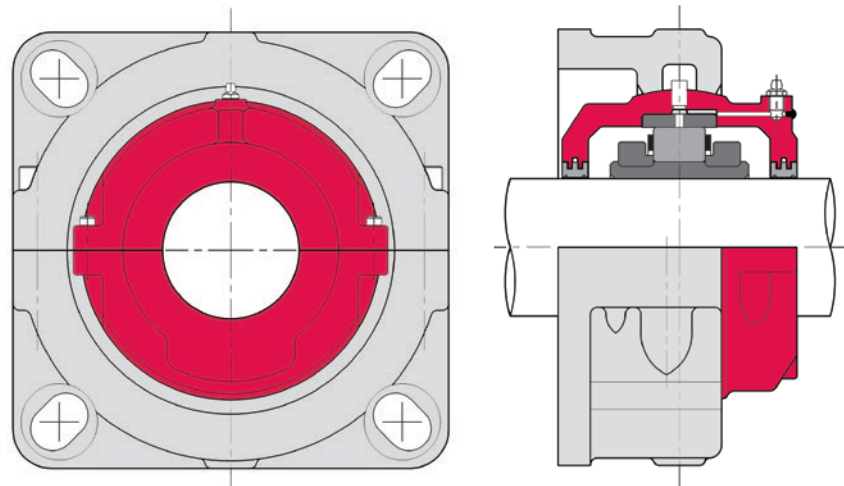

A further option, where it is desired for the bearing center to be closer to the mounting face, is the 'flat flange'.

FLAT FLANGE

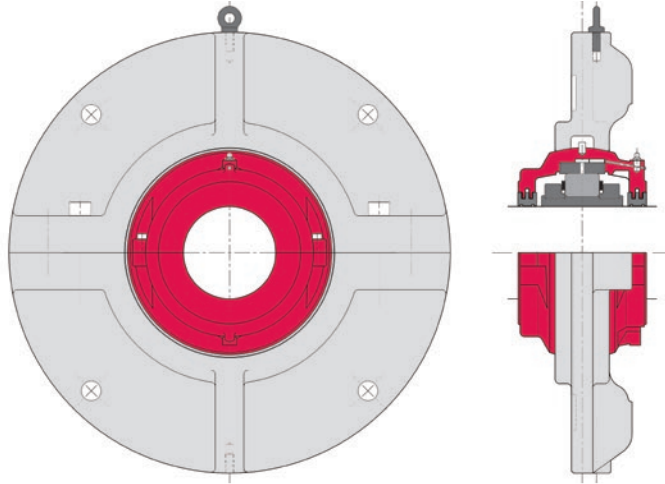

A typical application is on electric motors, where the flat flange is used to enclose the end of the motor housing as well as support the bearing.

Although the unit cannot be disassembled in a completely radial direction, by providing a sufficiently large aperture in the mounting face it is still possible to inspect and replace the bearing without disturbing the shaft.

If you wish to specify a flat flange please contact our technical department for details.

Flanges are common between expansion (EX) and fixed (GR) units. Where flat flanges are used on electrical equipment single lipped (GROSL) bearings are often specified (see page 5).

LOADS AND MOUNTING

The maximum radial load for standard round and square flanges is 26% of the static rating (Cor) of the corresponding roller bearing for 01 and 02 Series bearings, and 20% Cor for 01E, 02E and 100 Series bearings.

The maximum axial load is 25% of the axial rating (Ca) of the corresponding roller bearing for the 01 and 02 Series, 18% Ca for the 100 Series, and 13% for 01E and 02E Series bearings.

Ductile iron or steel flanges should be specified for shock conditions. Particulars are available on request from our technical department.

Standard flanges normally have drilled holes for the mounting bolts, with the outer surface as-cast. It is recommended that flat washers

are fitted under the bolt heads. Cast steel flanges usually have drilled holes with spotfacings for the bolt heads.

The rear face of round flanges is recessed for use with a spigot if required.

The bulkhead or support plate on which the flange is mounted must be of adequate strength and rigidity to support the imposed load with little distortion of the flange mounting area.

For vertical shafts bearings and flanges may require modified construction and special seals and lubrication. Please consult our technical department when considering applications with vertical shafts.

BULKHEAD SEALING

Where shafts are required to pass through sealed bulkheads the incorporation of additional sealing features into a Cooper flange unit can avoid the need for a separate bulkhead seal.

Generally, seals are added around the spherical seat in the flange, with optional sealing on the backface of the flange where it mounts to the bulkhead.

SRSRP seals are usually specified (see page 26). However, if the sealing is for emergency use only and a certain amount of leakage is permissible, other seal types may be possible.

Flange units with bulkhead sealing features are commonly used in marine drives. These units also often incorporate the feature of lubrication to the spherical seat, to allow for possible changing alignment of the shaft.

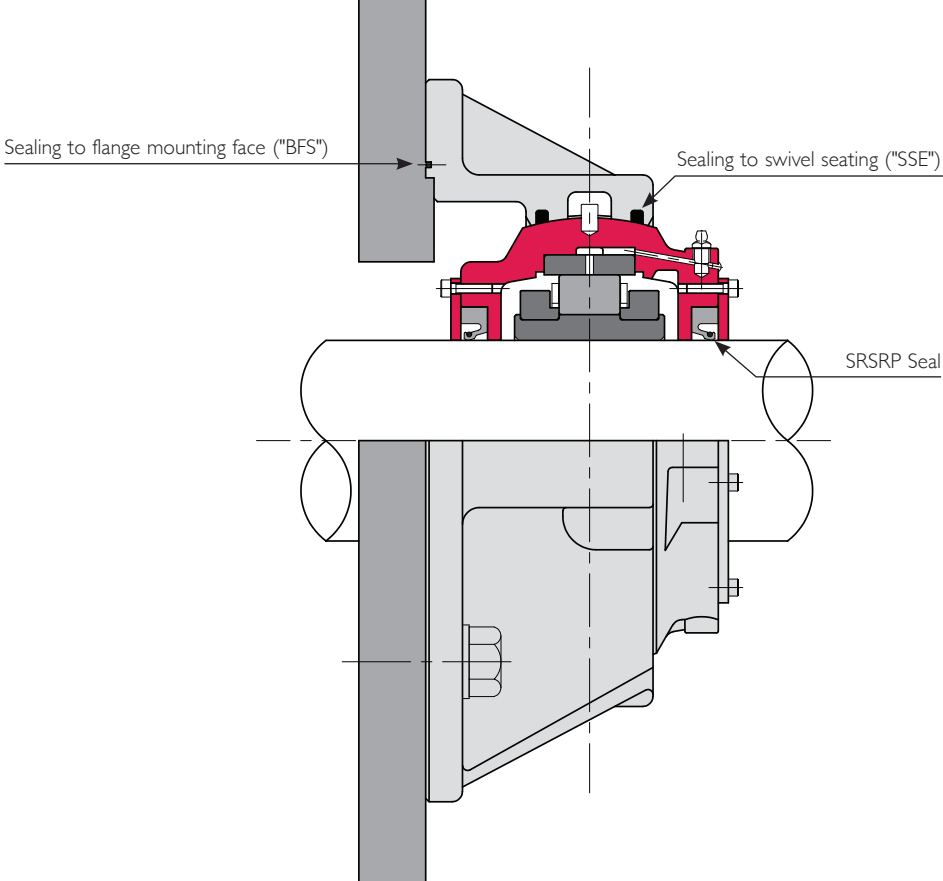

Inch-size Flange-Mounted Units From 1 3/16" To 3 1/4" Bore Size

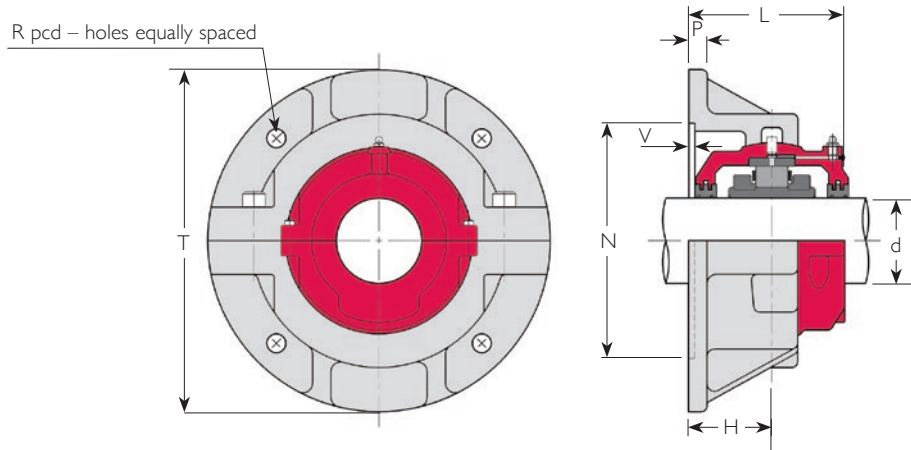

Shaft Diameter d (in)	References			T(3) (in)	Bolts			R (in)	P (in)	H (in)	N(4) (in)	V(4) (in)	L (in)	Mass (lb)	
	Bearing (1)	Complete Unit (2)	Flange Only		No.	Metric Size	Inch Size							Flange Only	Complete Unit
1 3/16	01 B 103	01 BCF 103 AT	F01	8	4	M12	1/2"	6 7/16	1/2	2	4 11/16	1/8	3 11/16	9.2	16.3
1 1/4	1 B 104	01 BCF 104 AT	F01	8	4	M12	1/2"	6 7/16	1/2	2	4 11/16	1/8	3 11/16	9.2	16.3
1 7/16	1 B 107	01 BCF 107 AT	F01	8	4	M12	1/2"	6 7/16	1/2	2	4 11/16	1/8	3 11/16	9.2	16.3
1 1/2	1 B 108	01 BCF 108 AT	F01	8	4	M12	1/2"	6 7/16	1/2	2	4 11/16	1/8	3 11/16	9.2	16.3
1 11/16	01E B 111	01E BCF 111 AT	F02	8 1/2	4	M12	1/2"	7 1/8	1/2	2 1/4	5 3/8	1/8	4 3/16	11.2	20.0
1 3/4	01E B 112	01E BCF 112 AT	F02	8 1/2	4	M12	1/2"	7 1/8	1/2	2 1/4	5 3/8	1/8	4 3/16	11.2	20.0
1 15/16	01E B 115	01E BCF 115 AT	F02	8 1/2	4	M12	1/2"	7 1/8	1/2	2 1/4	5 3/8	1/8	4 3/16	11.2	20.0
	02 B 115	01 BCF 115 AT	F03	10 1/4	4	M12	1/2"	8 9/16	5/8	2 5/8	6 9/16	1/8	4 7/8	20.0	33.2
2	01E B 200	01E BCF 200 AT	F02	8 1/2	4	M12	1/2"	7 1/8	1/2	2 1/4	5 3/8	1/8	4 3/16	11.2	20.0
	02 B 200	01 BCF 200 AT	F03	10 1/4	4	M12	1/2"	8 9/16	5/8	2 5/8	6 9/16	1/8	4 7/8	20.0	33.2
2 3/16	01E B 203	01E BCF 203 AT	F03	10 1/4	4	M12	1/2"	8 9/16	5/8	2 5/8	6 9/16	1/8	4 11/16	20.0	31.0
	02 B 203	01 BCF 203 AT	F04	11 1/4	4	M12	1/2"	9 1/2	5/8	2 7/8	7 9/16	1/8	5 3/8	27.3	49.3
2 1/4	01E B 204	01E BCF 204 AT	F03	10 1/4	4	M12	1/2"	8 9/16	5/8	2 5/8	6 9/16	1/8	4 11/16	20.0	31.0
	02 B 204	01 BCF 204 AT	F04	11 1/4	4	M12	1/2"	9 1/2	5/8	2 7/8	7 9/16	1/8	5 3/8	27.3	49.3
2 7/16	01E B 207	01E BCF 207 AT	F03	10 1/4	4	M12	1/2"	8 9/16	5/8	2 5/8	6 9/16	1/8	4 11/16	20.0	31.0
	02 B 207	01 BCF 207 AT	F04	11 1/4	4	M12	1/2"	9 1/2	5/8	2 7/8	7 9/16	1/8	5 3/8	27.3	49.3

- 1) For full references of bearings and cartridges see pages 36 to 38
- 2) Add 'EX' or 'GR' to complete unit reference for expansion type or fixed type respectively, e.g.: 01E BCF 207 EX AT

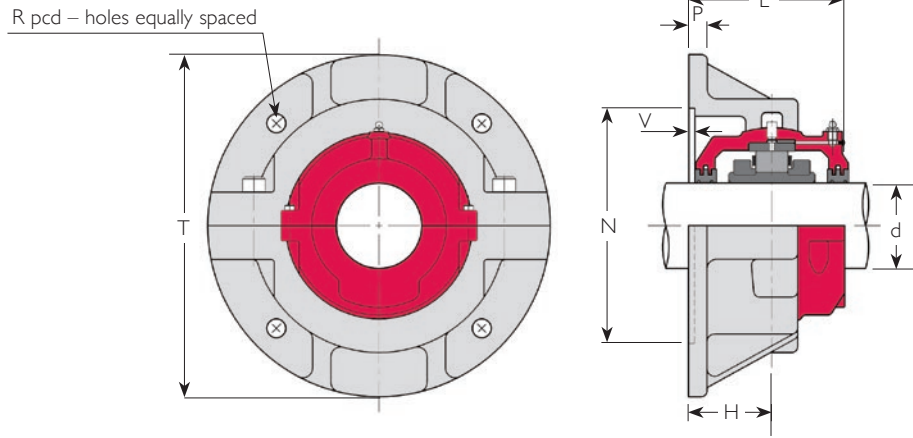

Shaft Diameter d (in)	References			T(3) (in)	Bolts			R (in)	P (in)	H (in)	N(4) (in)	V(4) (in)	L (in)	Mass (lb)	
	Bearing (1)	Complete Unit (2)	Flange Only		No.	Metric Size	Inch Size							Flange Only	Complete Unit
2 1/2	01E B 208	01E BCF 208 AT	F03	10 1/4	4	M12	1/2"	8 9/16	5/8	2 5/8	6 9/16	1/8	4 11/16	20.0	31.0
	02 B 208	02 BCF 208 AT	F04	11 1/4	4	M12	1/2"	9 1/2	5/8	2 7/8	7 9/16	1/8	5 3/8	27.3	49.3
2 11/16	01E B 211	01E BCF 211 AT	F04	11 1/4	4	M12	1/2"	9 1/2	5/8	2 7/8	7 9/16	1/8	5 1/8	27.3	44.9
	02 B 211	02 BCF 211 AT	F05	13	3	M16	5/8"	10 3/4	3/4	3 1/8	8 1/2	1/8	5 7/8	42.7	73.5
2 3/4	01E B 212	01E BCF 212 AT	F04	11 1/4	4	M12	1/2"	9 1/2	5/8	2 7/8	7 9/16	1/8	5 1/8	27.3	44.9
	02 B 212	02 BCF 212 AT	F05	13	3	M16	5/8"	10 3/4	5/8	3 1/8	8 1/2	1/8	5 7/8	42.7	73.5
2 15/16	100 B 215	100 BCF 215 AT	F03	10 1/4	4	M12	1/2"	8 9/16	5/8	2 5/8	6 9/16		4 11/16	20.0	30.6
	01E B 215	01E BCF 215 AT	F04	11 1/4	4	M12	1/2"	9 1/2	5/8	2 7/8	7 9/16	1/8	5 1/8	27.3	44.9
	02 B 215	02 BCF 215 AT	F05	13	4	M16	5/8"	10 3/4	3/4	3 1/8	8 1/2	1/8	5 7/8	42.7	73.5
3	100 B 300	100 BCF 300 AT	F03	10 1/4	4	M12	1/2"	8 9/16	5/8	2 5/8	6 9/16		4 11/16	20.0	30.6
	01E B 300	01E BCF 300 AT	F04	11 1/4	4	M12	1/2"	9 1/2	5/8	2 7/8	7 9/16	1/8	5 1/8	27.3	44.9
	2 B 300	02 BCF 300 AT	F05	13	4	M16	5/8"	10 3/4	3/4	3 1/8	8 1/2	1/8	5 7/8	42.7	73.5
3 3/16	01E B 303	01E BCF 303 AT	F05	13	4	M16	5/8"	10 3/4	3/4	3 1/8	8 1/2	1/8	5 13/16	42.7	66.9
	02 B 303	02 BCF 303 AT	F06	14	4	M16	5/8"	11 7/8	3/4	3 1/8	9 5/8	1/8	6 7/16	48.4	85.8
3 1/4	01E B 304	01E BCF 304 AT	F05	13	4	M16	5/8"	10 3/4	3/4	3 1/8	8 1/2	1/8	5 13/16	42.7	66.9
	02 B 304	02 BCF 304 AT	F06	14	4	M16	5/8"	11 7/8	3/4	3 1/8	9 5/8	1/8	6 7/16	48.4	85.8

- 3) Dimension shown is as-cast dimension. Depending upon manufacturing method used, flanges supplied may be machined 3/16" smaller.
- 4) Dimensions shown are for locating spigot for mounting flange on to. Diameter tolerance of locating spigot: f8

Inch-size Flange-Mounted Units From 3 7/16" To 5 3/16" Bore Size

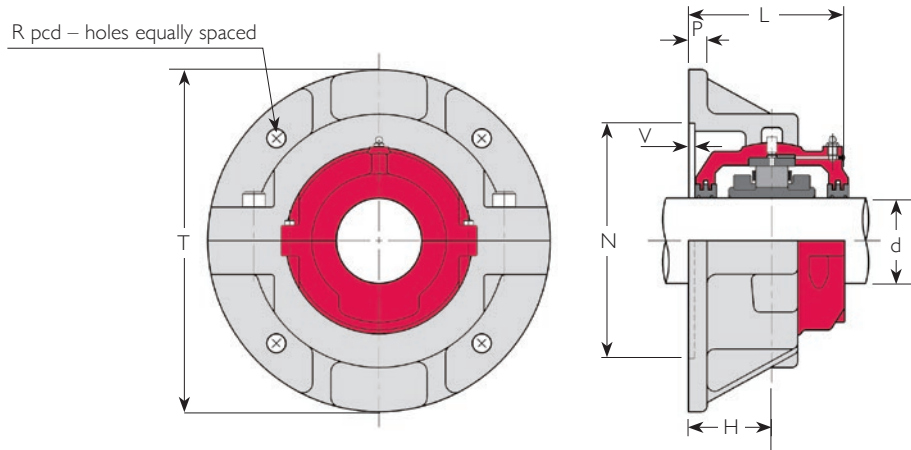

Shaft Diameter d (in)	References			T(3) (in)	Bolts			R (in)	P (in)	H (in)	N(4) (in)	V(4) (in)	L (in)	Mass (lb)	
	Bearing (1)	Complete Unit (2)	Flange Only		No.	Metric Size	Inch Size							Flange Only	Complete Unit
3 7/16	100 B 307	01E BCF 307 AT	F04	11 1/4	4	M12	1/2"	9 1/2	5/8	2 7/8	7 9/16	1/8	5 1/8	27.3	43.8
	01E B 307	01E BCF 307 AT	F05	13	4	M16	5/8"	10 3/4	3/4	3 1/8	8 1/2	1/8	5 13/16	42.7	66.9
	2 B 307	02 BCF 307 AT	F06	14	4	M16	5/8"	11 7/8	3/4	3 3/8	9 5/8	1/8	6 7/16	48.4	85.8
3 1/2	01E B 308	01E BCF 308 AT	F05	13	4	M16	5/8"	10 3/4	3/4	3 1/8	8 1/2	1/8	5 13/16	42.7	66.9
	02 B 308	02 BCF 308 AT	F06	14	4	M16	5/8"	11 7/8	3/4	3 3/8	9 5/8	1/8	6 7/16	48.4	85.8
3 11/16	01E B 311	01E BCF 311 AT	F06	14	4	M16	5/8"	11 7/8	3/4	3 3/8	9 5/8	1/8	6	48.4	79.2
	02 B 311	02 BCF 311 AT	F07	15	4	M16	5/8"	13 1/8	7/8	3 5/8	10 7/8	1/8	6 1/2	58.5	105
3 3/4	01E B 312	01E BCF 312 AT	F06	14	4	M16	5/8"	11 7/8	3/4	3 3/8	9 5/8	1/8	6	48.4	79.2
	02 B 312	02 BCF 312 AT	F07	15	4	M16	5/8"	13 1/8	7/8	3 5/8	10 7/8	1/8	6 1/2	58.5	105
3 15/16	100 B 315	100 BCF 315 AT	F05	13	4	M16	5/8"	10 3/4	3/4	3 1/8	8 1/2	1/8	5 13/16	42.7	65.1
	01E B 315	01E BCF 315 AT	F06	14	4	M16	5/8"	11 7/8	3/4	3 3/8	9 5/8	1/8	6	48.4	79.2
	02 B 315	02 BCF 315 AT	F07	15	4	M16	5/8"	13 1/8	7/8	3 5/8	10 7/8	1/8	6 1/2	58.5	105
4 3/16	01 B 403	01E BCF 403 AT	F07	15	4	M16	5/8"	13 1/8	7/8	3 5/8	10 7/8	1/8	6 7/16	58.5	107
	02 B 403	02 BCF 403 AT	F08	17	4	M24	1"	14 3/4	7/8	3 7/8	12 3/8	1/8	7 1/16	76.8	154

- 1) For full references of bearings and cartridges see pages 40 to 44
- 2) Add 'EX' or 'GR' to complete unit reference for expansion type or fixed type respectively, e.g.: 01E BCF 307 EX AT

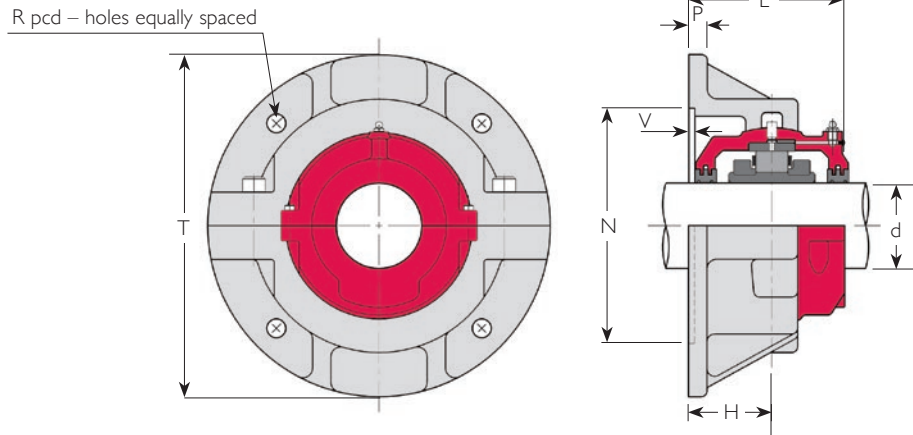

Shaft Diameter d (in)	References			T(3) (in)	Bolts			R (in)	P (in)	H (in)	N(4) (in)	V(4) (in)	L (in)	Mass (lb)	
	Bearing (1)	Complete Unit (2)	Flange Only		No.	Metric Size	Inch Size							Flange Only	Complete Unit
4 7/16	100 B 407	100 BCF 407 AT	F06	14	4	M16	5/8"	11 7/8	3/4	3 3/8	9 5/8	1/8	6	48.4	75.9
	01 B 407	01 BCF 407 AT	F07	15	4	M16	5/8"	13 1/8	7/8	3 5/8	10 7/8	1/8	6 7/16	58.5	107
	02 B 407	02 BCF 407 AT	F08	17	4	M24	1"	14 3/4	7/8	3 7/8	12 3/8	1/8	7 1/16	76.8	154
4 1/2	100 B 408	100 BCF 408 AT	F06	14	4	M16	5/8"	11 7/8	3/4	3 3/8	9 5/8	1/8	6	48.4	75.9
	01 B 408	01 BCF 408 AT	F07	15	4	M16	5/8"	13 1/8	7/8	3 5/8	10 7/8	1/8	6 7/16	58.5	107
	02 B 408	02 BCF 408 AT	F08	17	4	M24	1"	14 3/4	7/8	3 7/8	12 3/8	1/8	7 1/16	76.8	154
4 15/16	100 B 415	100 BCF 415 AT	F07	15	4	M16	5/8"	13 1/8	7/8	3 5/8	10 7/8	1/8	6 7/16	58.5	99.0
	01 B 415	01 BCF 415 AT	F08	17	4	M24	1"	14 3/4	7/8	3 7/8	12 3/8	1/8	6 15/16	76.8	148
	02 B 415	02 BCF 415 AT	F10	18 1/2	4	M24	1"	16 1/4	1	4 1/2	13 5/8	1/8	8 1/8	110	212
5	100 B 500	100 BCF 500 AT	F07	15	4	M16	5/8"	13 1/8	7/8	3 5/8	10 7/8	1/8	6 7/16	58.5	99.0
	01 B 500	01 BCF 500 AT	F08	17	4	M24	1"	14 3/4	7/8	3 7/8	12 3/8	1/8	6 15/16	76.8	148
	02 B 500	02 BCF 500 AT	F10	18 1/2	4	M24	1"	16 1/4	1	4 1/2	13 5/8	1/8	8 1/8	110	212
5 3/16	01 B 503	01 BCF 503 AT	F09	17 1/2	4	M24	1"	15 1/8	1	3 7/8	12 1/2	1/8	7 3/16	89.8	169
	02 B 503	02 BCF 503 AT	F30	20	4	M24	1"	17 1/2	1	4 1/2	14 7/8	1/8	8 3/16	147	273

3) Dimension shown is as-cast dimension. Depending upon manufacturing method used, flanges supplied may be machined 3/16" smaller.

4) Dimensions shown are for locating spigot for mounting flange on to. Diameter tolerance of locating spigot: f8

Inch-size Flange-Mounted Units From 5 7/16" To 9" Bore Size

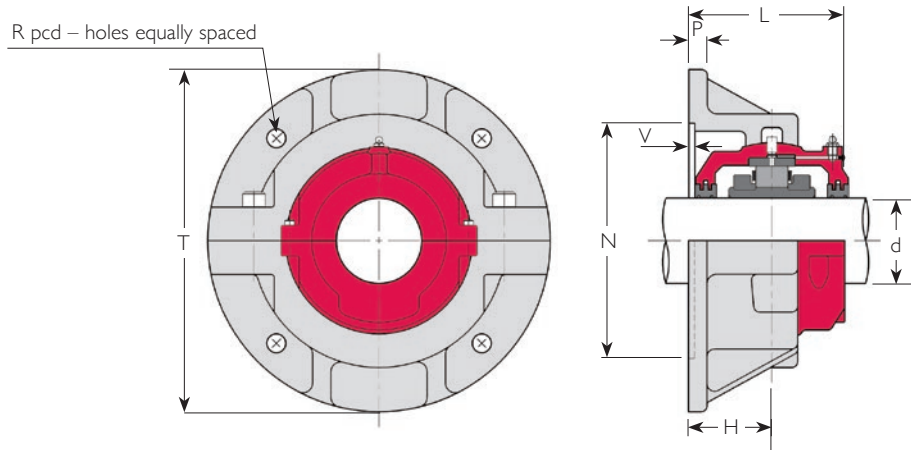

Shaft Diameter d (in)	References			T(3) (in)	Bolts			R (in)	P (in)	H (in)	N(4) (in)	V(4) (in)	L (in)	Mass (lb)	
	Bearing (1)	Complete Unit (2)	Flange Only		No.	Metric Size	Inch Size							Flange Only	Complete Unit
5 7/16	100 B 507	100 BCF 507 AT	F08	17	4	M24	1"	14 3/4	7/8	3 7/8	12 3/8	1/8	6 15/16	76.8	138
	01 B 507	01 BCF 507 AT	F09	17 1/2	4	M24	1"	15 1/8	1	3 7/8	12 1/2	1/8	7 3/16	89.8	169
	02 B 507	02 BCF 507 AT	F30	20	4	M24	1"	17 1/2	1	4 1/2	14 7/8	1/8	8 3/16	147	273
5 1/2	100 B 508	100 BCF 508 AT	F08	17	4	M24	1"	14 3/4	7/8	3 7/8	12 3/8	1/8	6 15/16	76.8	138
	01 B 508	01 BCF 508 AT	F09	17 1/2	4	M24	1"	15 1/8	1	3 7/8	12 1/2	1/8	7 3/16	89.8	169
	02 B 508	02 BCF 508 AT	F30	20	4	M24	1"	17 1/2	1	4 1/2	14 7/8	1/8	8 3/16	147	273
5 15/16	100 B 515	100 BCF 515 AT	F09	17 1/2	4	M24	1"	15 1/8	1	3 7/8	12 1/2	1/8	7 3/16	89.8	155
	01 B 515	01 BCF 515 AT	F10	18 1/2	4	M24	1"	16 1/4	1	4 1/2	13 5/8	1/8	7 15/16	110	201
	02 B 515	02 BCF 515 AT	F31	21	4	M24	1"	18 3/8	1	4 7/8	15 1/2	1/8	8 7/8	178	328
6	100 B 600	100 BCF 600 AT	F09	17 1/2	4	M24	1"	15 1/8	1	3 7/8	12 1/2	1/8	7 3/16	89.8	155
	01 B 600	01 BCF 600 AT	F10	18 1/2	4	M24	1"	16 1/4	1	4 1/2	13 5/8	1/8	7 15/16	110	201
	02 B 600	02 BCF 600 AT	F31	21	4	M24	1"	18 3/8	1	4 7/8	15 1/2	1/8	8 7/8	178	328

- 1) For full references of bearings and cartridges see pages 44 to 48
- 2) Add 'EX' or 'GR' to complete unit reference for expansion type or fixed type respectively, e.g.: 01E BCF 800 EX AT

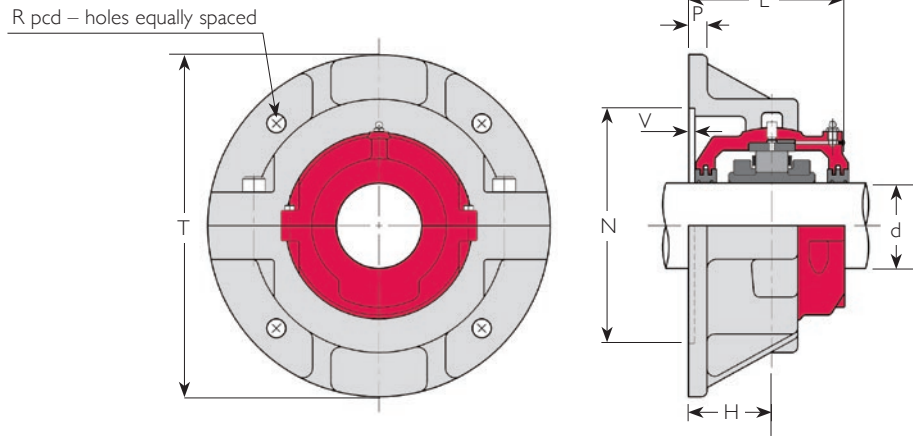

Shaft Diameter d (in)	References			T(3) (in)	Bolts			R (in)	P (in)	H (in)	N(4) (in)	V(4) (in)	L (in)	Mass (lb)	
	Bearing (1)	Complete Unit (2)	Flange Only		No.	Metric Size	Inch Size							Flange Only	Complete Unit
6 7/16	01E B 607	01E BCF 607 AT	F11	19 1/2	4	M24	1"	16 3/4	1	4 1/8	13 7/8	1/8	7 15/16	128	240
	02E B 607	02E BCF 607 AT	F32	23	4	M30	1 1/4"	20	1 1/8	4 7/8	16 7/8	3/16	9 7/16	209	418
6 1/2	01E B 608	01E BCF 608 AT	F11	19 1/2	4	M24	1"	16 3/4	1	4 1/8	13 7/8	1/8	7 15/16	128	240
	02E B 608	02E BCF 608 AT	F32	23	4	M30	1 1/4"	20	1 1/8	4 7/8	16 7/8	3/16	9 7/16	209	418
6 15/16	01E B 615	01E BCF 615 AT	F12	20	4	M24	1"	17 1/4	1 1/8	4 1/4	14 3/8	1/8	8 3/16	136	255
	02E B 615	02E BCF 615 AT	F33	23 1/2	4	M30	1 1/4"	20 5/8	1 1/4	5 1/8	17 1/2	3/16	9 7/8	220	464
7	01E B 700	01E BCF 700 AT	F12	20	4	M24	1"	17 1/4	1 1/8	4 1/4	14 3/8	1/8	8 3/16	136	255
	02E B 700	02E BCF 700 AT	F33	23 1/2	4	M30	1 1/4"	20 5/8	1 1/4	5 1/8	17 1/2	3/16	9 7/8	220	464
7 15/16	01E B 715	01E BCF 715 AT	F13	21	4	M24	1"	18 5/8	1 1/4	4 1/4	15 3/4	1/8	8 3/16	156	302
	02E B 715	02E BCF 715 AT	F34	25 1/2	4	M30	1 1/4"	22 1/2	1 1/4	5 3/8	19 3/8	3/16	10 7/16	304	619
8	01E B 800	01E BCF 800 AT	F13	21	4	M24	1"	18 5/8	1 1/4	4 1/4	15 3/4	1/8	8 3/16	156	302
	02E B 800	02E BCF 800 AT	F34	25 1/2	4	M30	1 1/4"	22 1/2	1 1/4	5 3/8	19 3/8	3/16	10 7/16	304	619
9	01E B 900	01E BCF 900 AT	F14	23	4	M30	1 1/4"	20 1/8	1 3/8	4 5/8	17	1/8	8 7/8	187	359
	02E B 900	02E BCF 900 AT	F35	28	4	M36	1 1/2"	24 3/8	1 3/8	5 3/4	20 3/4	3/16	11 1/8	319	685

3) Dimension shown is as-cast dimension. Depending upon manufacturing method used, flanges supplied may be machined 3/16" smaller.

4) Dimensions shown are for locating spigot for mounting flange on to. Diameter tolerance of locating spigot: f8

Inch-size Flange-Mounted Units From 10" To 16" Bore Size

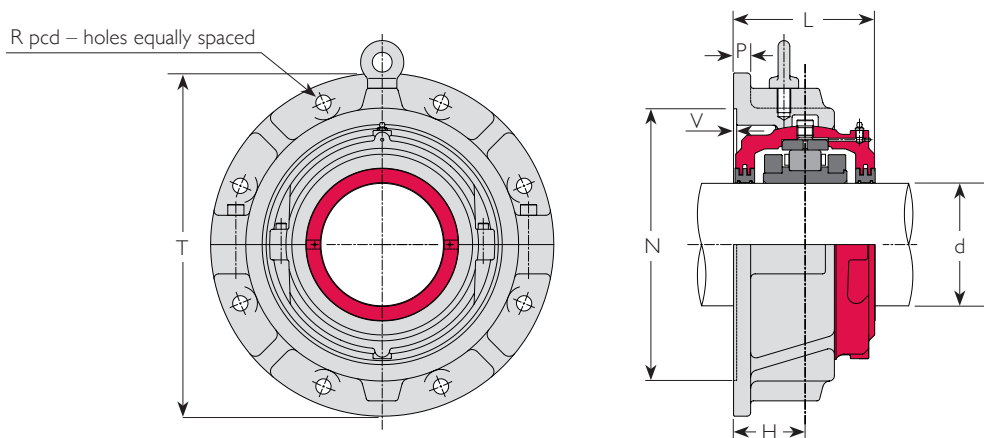

Shaft Diameter d (in)	References			T(3) (in)	Bolts			R (in)	P (in)	H (in)	N(4) (in)	V(4) (in)	L (in)	Mass (lb)	
	Bearing (1)	Complete Unit (2)	Flange Only		No.	Metric Size	Inch Size							Flange Only	Complete Unit
10	01E B 1000	01E BCF 1000 AT	F15	24	4	M30	1 1/4"	21 3/8	1 3/8	4 5/8	18 1/4	1/8	9	220	436
	02E B 1000	02E BCF 1000 AT	F36	29	4	M36	1 1/2"	26	1 1/2	5 7/8	22 3/8	3/16	11 3/8	392	792
11	01E B 1100	01E BCF 1100 AT	F16	26	4	M30	1 1/4"	23	1 1/2	4 7/8	19 7/8	1/8	9 7/16	255	520
	02E B 1100	02E BCF 1100 AT	F37	30	8	M30	1 1/4"	26 7/8	1 1/2	6 1/4	23 3/4	3/16	12 3/16	429	907
12	01E B 1200	01E BCF 1200 AT	F17	28	4	M30	1 1/4"	24 5/8	1 1/2	5 1/4	21 1/4	1/8	10 1/8	262	583
	02E B 1200	02E BCF 1200 AT	F38	31	8	M30	1 1/4"	27 7/8	1 5/8	6 3/8	24 3/4	3/16	12 3/8	429	984
13	01 B 1300	01 BCF 1300 AT	F18	32	4	M36	1 1/2"	27 1/2	1 1/2	6	23	3/16	11 3/8	405	797
	02 B 1300	02 BCF 1300 AT	F39	36	8	M30	1 1/4"	31 1/2	1 3/4	7 1/2	26.77	1/4	14	680	1389
14	01 B 1400	01 BCF 1400 AT	F19	33 1/2	4	M36	1 1/2"	29	1 9/16	5 1/2	24.02	1/4	10 7/8	455	885
15	01 B 1500	01 BCF 1500 AT	F20	36	8	M30	1 1/4"	31 1/2	1 3/4	6 1/2	26 1/2	3/16	12	607	1074
16	01 B 1600	01 BCF 1600 AT	F21	36	8	M30	1 1/4"	31 1/2	1 3/4	6 1/2	26 1/2	3/16	12 1/8	601	1120

1) For full references of bearings and cartridges see pages 48 to 50

2) Add 'EX' or 'GR' to complete unit reference for expansion type or fixed type respectively, e.g.: 01E BCF 1000 EX AT

3) Dimension shown is as-cast dimension. Depending upon manufacturing method used, flanges supplied may be machined 3/16" smaller:

4) Dimensions shown are for locating spigot for mounting flange on to. Diameter tolerance of locating spigot: f8

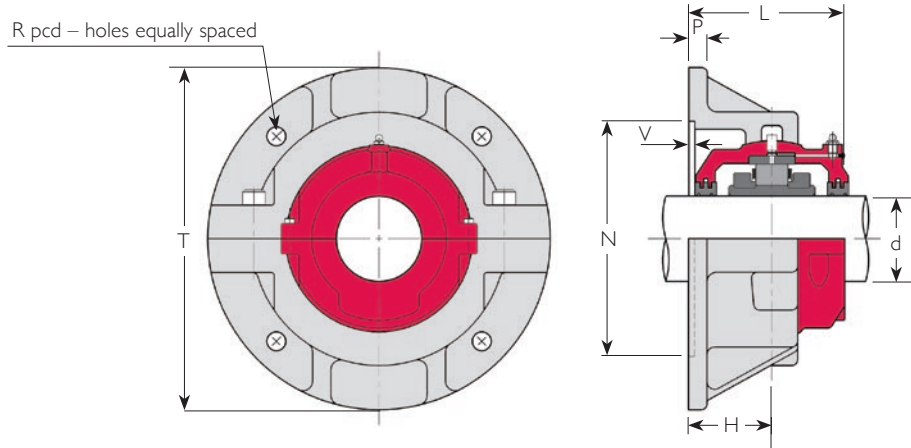

Shaft Diameter d (mm)	References			T(3) (mm)	Bolts			R (mm)	P (mm)	H (mm)	N(4) (mm)	V(4) (mm)	L (mm)	Mass (kg)	
	Bearing (1)	Flange Only	Complete Unit (2)		No.	Metric Size	Inch Size							Flange Only	Complete Unit
35	01 B 35M	F01	01 BCF 35M AT	204	4	M12	1/2"	164	13	51	119.06	3	94	4.2	7.4
40	01 B 40M	F01	01 BCF 40M AT	204	4	M12	1/2"	164	13	51	119.06	3	94	4.2	7.4
45	01E B 45M	F02	01E BCF 45M AT	216	4	M12	1/2"	180	13	57	136.53	3	106	5.1	9.1
50	01E B 50M	F02	01E BCF 50M AT	216	4	M12	1/2"	180	13	57	136.53	3	106	5.1	9.1
	02 B 50M	F03	02 BCF 50M AT	260	4	M12	1/2"	218	16	67	166.69	3	124	9.1	15.1
55	01E B 55M	F03	01E BCF 55M AT	260	4	M12	1/2"	218	16	67	166.69	3	119	9.1	14.1
60	01E B 60M	F03	01E BCF 60M AT	260	4	M12	1/2"	218	16	67	166.69	3	119	9.1	14.1
	02 B 60M	F04	02 BCF 60M AT	286	4	M12	1/2"	242	16	73	192.09	3	136	12.4	22.4
65	01E B 65M	F03	01E BCF 65M AT	260	4	M12	1/2"	218	16	67	166.69	3	119	9.1	14.1
	02 B 65M	F04	02 BCF 65M AT	286	4	M12	1/2"	242	16	73	192.09	3	136	12.4	22.4
70	01E B 70M	F04	01E BCF 70M AT	286	4	M12	1/2"	242	16	73	192.09	3	130	12.4	20.4
	02 B 70M	F05	02 BCF 70M AT	330	4	M16	5/8"	274	19	79	215.90	3	149	19.4	33.4
75	100 B 75M	F03	100 BCF 75M AT	260	4	M12	1/2"	218	16	67	166.69	3	119	9.1	13.9
	01E B 75M	F04	01E BCF 75M AT	286	4	M12	1/2"	242	16	73	192.09	3	130	12.4	20.4
	02 B 75M	F05	02 BCF 75M AT	330	4	M16	5/8"	274	19	79	215.90	3	149	19.4	33.4

1) For full references of bearings and cartridges see page 54

2) Add 'EX' or 'GR' to complete unit reference for expansion type or fixed type respectively, e.g.: 01E BCF 50M EX AT

3) Dimension shown is as-cast dimension. Depending upon manufacturing method used, flanges supplied may be machined 5mm smaller.

4) Dimensions shown are for locating spigot for mounting flange on to. Diameter tolerance of locating spigot: f8

Metric Round Flange-Mounted Units From 80mm To 140mm Bore Size

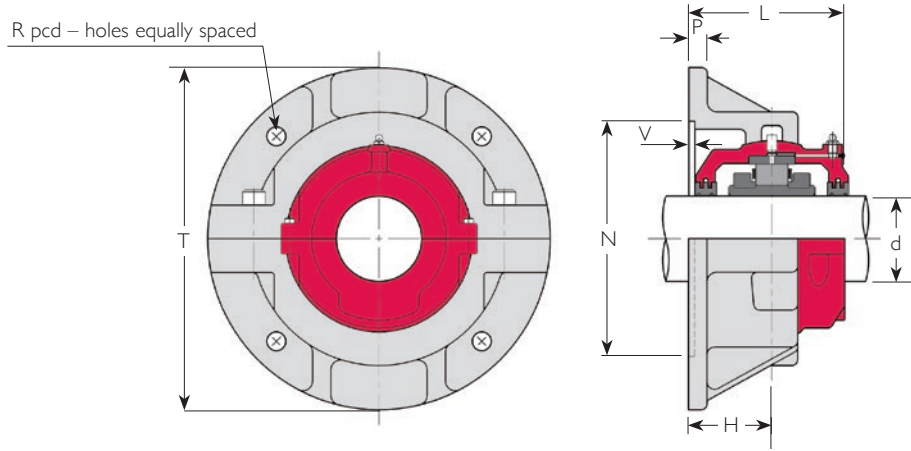

Shaft Diameter d (mm)	References			T(3) (mm)	Bolts			R (mm)	P (mm)	H (mm)	N(4) (mm)	V(4) (mm)	L (mm)	Mass (kg)	
	Bearing (1)	Flange Only	Complete Unit (2)		No.	Metric Size	Inch Size							Flange Only	Complete Unit
80	01E B 80M	F05	01E BCF 80M AT	330	4	M16	5/8"	274	19	79	215.90	3	147	19.4	30.4
	02 B 80M	F06	02 BCF 80M AT	356	4	M16	5/8"	302	19	86	244.48	3	163	22.0	39.0
85	100 B 85M	F04	100 BCF 85M AT	286	4	M12	1/2"	242	16	73	192.09	3	130	12.4	19.9
	01E B 85M	F05	01E BCF 85M AT	330	4	M16	5/8"	274	19	79	215.90	3	147	19.4	30.4
90	02 B 85M	F06	02 BCF 85M AT	356	4	M16	5/8"	302	19	86	244.48	3	163	22.0	39.0
	01E B 90M	F05	01E BCF 90M AT	330	4	M16	5/8"	274	19	79	215.90	3	147	19.4	30.4
95	02 B 90M	F06	02 BCF 90M AT	356	4	M16	5/8"	302	19	86	244.48	3	163	22.0	39.0
	01E B 95M	F06	01E BCF 95M AT	356	4	M16	5/8"	302	19	86	244.48	3	153	22.0	36.0
100	100 B 100M	F05	100 BCF 100M AT	330	4	M16	5/8"	274	19	79	215.90	3	147	19.4	29.6
	01E B 100M	F06	01E BCF 100M AT	356	4	M16	5/8"	302	19	86	244.48	3	153	22.0	36.0
	02 B 100M	F07	02 BCF 100M AT	382	4	M16	5/8"	334	22	92	276.23	3	165	26.6	47.6
105	01E B 105M	F06	01E BCF 105M AT	356	4	M16	5/8"	302	19	86	244.48	3	153	22.0	36.0
	02 B 105M	F07	02 BCF 105M AT	382	4	M16	5/8"	334	22	92	276.23	3	165	26.6	47.6
110	100 B 110M	F06	100 BCF 110M AT	356	4	M16	5/8"	302	19	86	244.48	3	153	22.0	34.5
	01 B 110M	F07	01 BCF 110M AT	382	4	M16	5/8"	334	22	92	276.23	3	163	26.6	48.7
	02 B 110M	F08	02 BCF 110M AT	432	4	M24	1"	374	22	98	314.33	3	179	34.9	70

- 1) For full references of bearings and cartridges see pages 56 to 60
- 2) Add 'EX' or 'GR' to complete unit reference for expansion type or fixed type respectively, e.g.: 01E BCF 100M EX AT

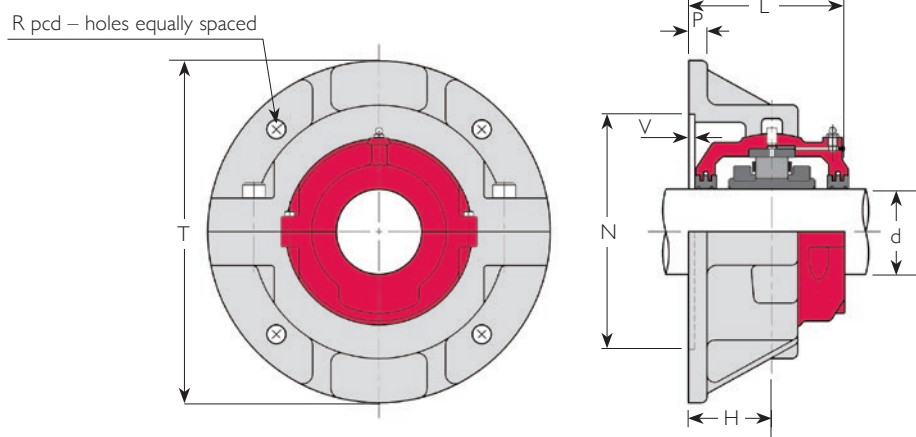

Shaft Diameter d (mm)	References			T(3) (mm)	Bolts			R (mm)	P (mm)	H (mm)	N(4) (mm)	V(4) (mm)	L (mm)	Mass (kg)	
	Bearing (1)	Flange Only	Complete Unit (2)		No.	Metric Size	Inch Size							Flange Only	Complete Unit
115	01 B 115M	F07	01 BCF 115M AT	382	4	M16	5/8"	334	22	92	276.23	3	163	26.6	48.7
	02 B 115M	F08	02 BCF 115M AT	432	4	M24	1"	374	22	98	314.33	3	179	34.9	70
120	100 B 120M	F07	100 BCF 120M AT	382	4	M16	5/8"	334	22	92	276.23	3	163	26.6	45.0
	01 B 120M	F08	01 BCF 120M AT	432	4	M24	1"	374	22	98	314.33	3	176	34.9	67
	02 B 120M	F10	02 BCF 120M AT	470	4	M24	1"	412	25	114	346.07	3	206	50.2	96
125	01 B 125M	F08	01 BCF 125M AT	432	4	M24	1"	374	22	98	314.33	3	176	34.9	67
	02 B 125M	F10	02 BCF 125M AT	470	4	M24	1"	412	25	114	346.07	3	206	50.2	96
130	100 B 130M	F07	100 BCF 130M AT	382	4	M16	5/8"	334	22	92	276.23	3	163	26.6	45.0
	01 B 130M	F08	01 BCF 130M AT	432	4	M24	1"	374	22	98	314.33	3	176	34.9	67
	02 B 130M	F10	02 BCF 130M AT	470	4	M24	1"	412	25	114	346.07	3	206	50.2	96
135	01 B 135M	F09	01 BCF 135M AT	444	4	M24	1"	384	25	98	317.50	3	182	40.8	77
	02 B 135M	F30	02 BCF 135M AT	508	4	M24	1"	444	25	114	377.82	3	208	67	124
140	100 B 140M	F08	100 BCF 140M AT	432	4	M24	1"	374	22	98	314.33	3	176	34.9	63
	01 B 140M	F09	01 BCF 140M AT	444	4	M24	1"	384	25	98	317.50	3	182	40.8	77
	02 B 140M	F30	02 BCF 140M AT	508	4	M24	1"	444	25	114	377.82	3	208	67	124

3) Dimension shown is as-cast dimension. Depending upon manufacturing method used, flanges supplied may be machined 5mm smaller.

4) Dimensions shown are for locating spigot for mounting flange on to. Diameter tolerance of locating spigot: f8

Metric Round Flange-Mounted Units From 145mm To 220mm Bore Size

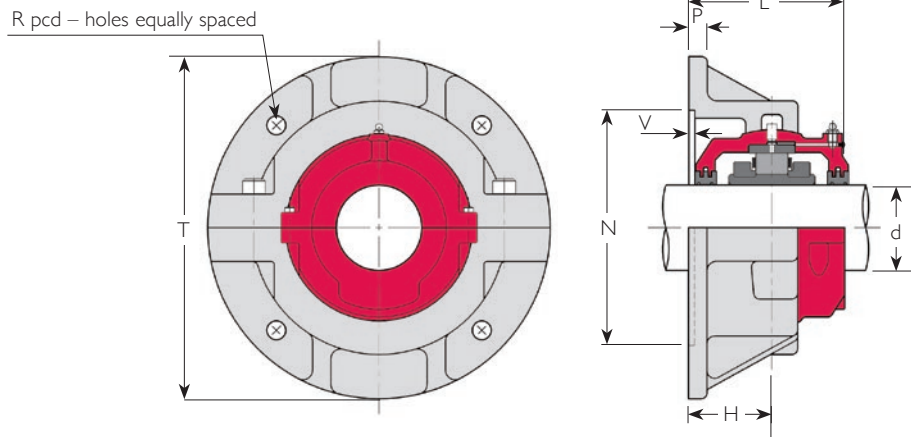

Shaft Diameter d (mm)	References			T(3) (mm)	Bolts			R (mm)	P (mm)	H (mm)	N(4) (mm)	V(4) (mm)	L (mm)	Mass (kg)	
	Bearing (1)	Flange Only	Complete Unit (2)		No.	Metric Size	Inch Size							Flange Only	Complete Unit
145	02 B 145M	F30	02 BCF 145M AT	508	4	M24	1"	444	25	114	377.82	3	208	67	124
	100 B 150M	F09	100 BCF 150M AT	444	4	M24	1"	384	25	98	317.50	3	182	40.8	71
150	01 B 150M	F10	01 BCF 150M AT	470	4	M24	1"	412	25	114	346.07	3	201	50.2	91
	02 B 150M	F31	02 BCF 150M AT	534	4	M24	1"	466	25	124	393.70	3	226	81	149
155	01 B 155M	F10	01 BCF 155M AT	470	4	M24	1"	412	25	114	346.07	3	201	50.2	91
	02 B 155M	F31	02 BCF 155M AT	534	4	M24	1"	466	25	124	393.70	3	226	81	149

- 1) For full references of bearings and cartridges see pages 60 to 64
- 2) Add 'EX' or 'GR' to complete unit reference for expansion type or fixed type respectively, e.g.: 01 BCF 150M EX AT

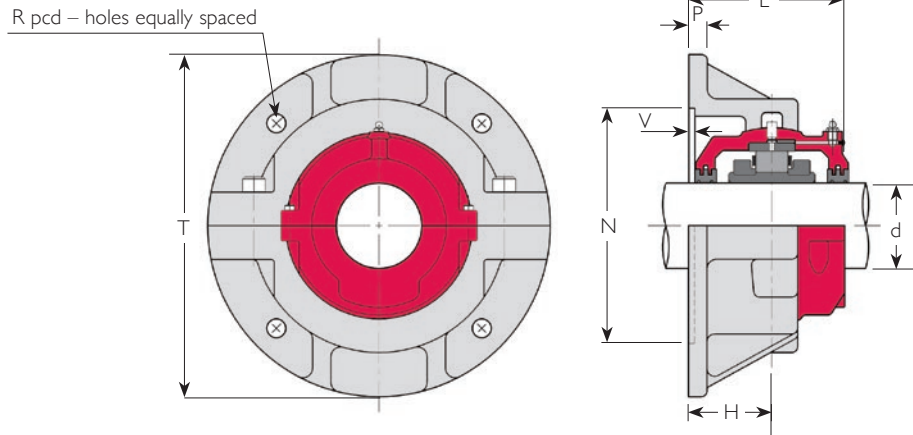

Shaft Diameter d (mm)	References			T(3) (mm)	Bolts			R (mm)	P (mm)	H (mm)	N(4) (mm)	V(4) (mm)	L (mm)	Mass (kg)	
	Bearing (1)	Flange Only	Complete Unit (2)		No.	Metric Size	Inch Size							Flange Only	Complete Unit
160	01 B 600-160M	F10	01 BCF 600-160M AT	470	4	M24	1"	412	25	114	346.07	3	201	50	91
	01E B 160M	F11	01E BCF 160M AT	496	4	M24	1"	426	25	105	352.43	3	201	58	109
	02 B 600-160M	F31	02 BCF 600-160M AT	534	4	M24	1"	466	25	124	393.70	3	226	81	149
	02E B 160M	F32	02E BCF 160M AT	584	4	M30	1 1/4"	508	29	124	428.63	5	240	95	190
170	01E B 608-170M	F11	01E BCF 608-170M AT	496	4	M24	1"	426	25	105	352.43	3	201	58	109
	01E B 170M	F12	01E BCF 170M AT	508	4	M24	1"	438	29	108	365.13	3	208	62	116
	02E B 170M	F32	02E BCF 170M AT	584	4	M30	1 1/4"	508	29	124	428.63	5	240	95	190
175	01E B 175M	F12	01E BCF 175M AT	508	4	M24	1"	438	29	108	365.13	3	208	62	116
	02E B 175M	F33	02E BCF 175M AT	596	4	M30	1 1/4"	524	32	130	444.50	5	251	100	211
180	01E B 180M	F12	01E BCF 180M AT	508	4	M24	1"	438	29	108	365.13	3	208	62	116
	02E B 180M	F33	02E BCF 180M AT	596	4	M30	1 1/4"	524	32	130	444.50	5	251	100	211
190	01E B 190M	F13	01E BCF 190M AT	534	4	M24	1"	474	32	108	400.05	3	208	71	137
	02E B 190M	F34	02E BCF 190M AT	648	4	M30	1 1/4"	572	32	137	492.13	5	266	138	281
200	01E B 200M	F13	01E BCF 200M AT	534	4	M24	1"	474	32	108	400.05	3	208	71	137
	02E B 200M	F34	02E BCF 200M AT	648	4	M30	1 1/4"	572	32	137	492.13	5	266	138	281
220	01E B 220M	F14	01E BCF 220M AT	584	4	M30	1 1/4"	512	35	117	431.80	3	225	85	163
	02E B 220M	F35	02E BCF 220M AT	715	4	M36	1 1/2"	620	35	146	527.05	5	283	145	311

3) Dimension shown is as-cast dimension. Depending upon manufacturing method used, flanges supplied may be machined 5mm smaller.

4) Dimensions shown are for locating spigot for mounting flange on to. Diameter tolerance of locating spigot: f8

Metric Round Flange-Mounted Units From 230mm To 400mm Bore Size

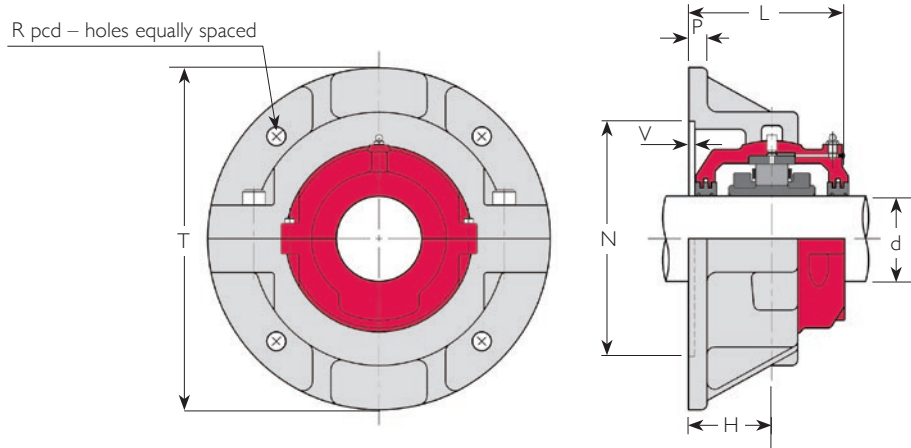

Shaft Diameter d (mm)	References			T(3) (mm)	Bolts		R (mm)	P (mm)	H (mm)	N(4) (mm)	V(4) (mm)	L (mm)	Mass (kg)		
	Bearing (1)	Flange Only	Complete Unit (2)		No.	Metric Size							Inch Size	Flange Only	Complete Unit
230	01E B 230M	F14	01E BCF 230M AT	584	4	M30	1 1/4"	512	35	117	431.80	3	225	85	163
	02E B 230M	F35	02E BCF 230M AT	712	4	M36	1 1/2"	620	35	146	527.05	5	283	145	311
240	01E B 240M	F15	01E BCF 240M AT	610	4	M30	1 1/4"	542	35	117	463.55	3	228	100	198
	02E B 240M	F36	02E BCF 240M AT	736	4	M36	1 1/2"	660	38	149	568.33	5	289	178	360
250	01E B 250M	F15	01E BCF 250M AT	610	4	M30	1 1/4"	542	35	117	463.55	3	228	100	198
	02E B 250M	F36	02E BCF 250M AT	736	4	M36	1 1/2"	660	38	149	568.33	5	289	178	360
260	01E B 1000-260M	F15	01E BCF 1000-260M AT	610	4	M30	1 1/4"	542	35	117	463.55	3	228	100	198
	01E B 260M	F16	01E BCF 260M AT	660	4	M30	1 1/4"	584	38	124	504.83	3	240	116	236
	02E B 260M	F36	02E BCF 260M AT	736	4	M36	1 1/2"	660	38	149	568.33	5	289	178	360
270	01E B 270M	F16	01E BCF 270M AT	660	4	M30	1 1/4"	584	38	124	504.83	3	240	116	236
275	01E B 275M	F16	01E BCF 275M AT	660	4	M30	1 1/4"	584	38	124	504.83	3	240	116	236
280	01E B 280M	F16	01E BCF 280M AT	660	4	M30	1 1/4"	584	38	124	504.83	3	240	116	236
	02E B 280M	F37	02E BCF 280M AT	762	8	M30	1 1/4"	682	38	159	603.25	5	309	195	412
290	01E B 290M	F17	01E BCF 290M AT	712	4	M30	1 1/4"	626	38	133	539.75	3	257	119	265
300	01E B 300M	F17	01E BCF 300M AT	712	4	M30	1 1/4"	626	38	133	539.75	3	257	119	265
	02E B 300M	F38	02E BCF 300M AT	788	8	M30	1 1/4"	708	41	162	628.65	5	315	195	447

- 1) For full references of bearings and cartridges see pages 64 to 70
- 2) Add 'EX' or 'GR' to complete unit reference for expansion type or fixed type respectively, e.g.: 01 BCF 300M EX AT

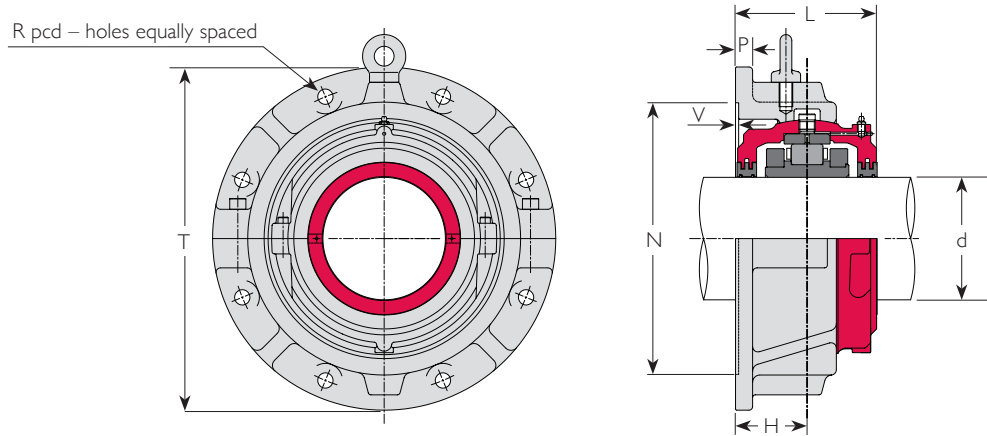

Shaft Diameter d (mm)	References			T(3) (mm)	Bolts			R (mm)	P (mm)	H (mm)	N(4) (mm)	V(4) (mm)	L (mm)	Mass (kg)	
	Bearing (1)	Flange Only	Complete Unit (2)		No.	Metric Size	Inch Size							Flange Only	Complete Unit
320	01 B 320M	F18	01 BCF 320M AT	812	4	M36	1 1/2"	698	38	152	584.20	5	288	184	362
	02 B 320M	F39	02 BCF 320M AT	914	8	M30	1 1/4"	800	45	190	680.00	7	355	309	631
330	01 B 330M	F18	01 BCF 330M AT	812	4	M36	1 1/2"	698	38	152	584.20	5	288	184	362
	02 B 330M	F39	02 BCF 330M AT	914	8	M30	1 1/4"	800	45	190	680.00	7	355	309	631
340	01 B 1300-340M	F18	01 BCF 1300-340M AT	812	4	M36	1 1/2"	698	38	152	584.20	5	288	184	362
	01 B 340M	F19	01 BCF 340M AT	850	4	M36	1 1/2"	738	40	140	610.00	7	276	207	402
350	01 B 350M	F19	01 BCF 350M AT	850	4	M36	1 1/2"	738	40	140	610.00	7	276	207	402
360	01 B 1400-360M	F19	01 BCF 1400-360M AT	850	4	M36	1 1/2"	738	40	140	610.00	7	276	207	402
	01 B 360M	F20	01 BCF 360M AT	914	8	M30	1 1/4"	800	44	165	673.10	5	305	276	488
380	01 B 380M	F20	01 BCF 380M AT	914	8	M30	1 1/4"	800	44	165	673.10	5	305	276	488
390	01 B 390M	F21	01 BCF 390M AT	914	8	M30	1 1/4"	800	44	165	673.10	5	308	273	509
400	01 B 400M	F21	01 BCF 400M AT	914	8	M30	1 1/4"	800	44	165	673.10	5	308	273	509

3) Dimension shown is as-cast dimension. Depending upon manufacturing method used, flanges supplied may be machined 5mm smaller.

4) Dimensions shown are for locating spigot for mounting flange on to. Diameter tolerance of locating spigot: f8

Inch-Size Square Flange-Mounted Units

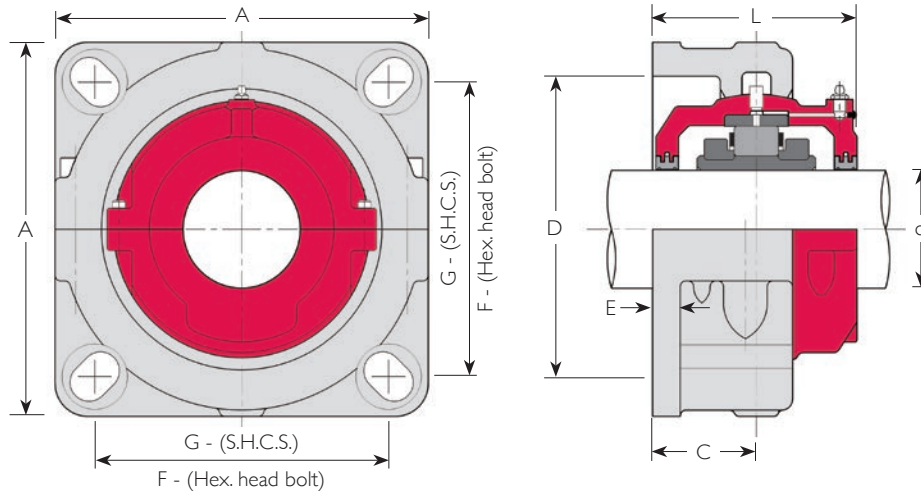

Shaft Diameter d (in)	Bearing Reference (1)	References		A (in)	SHCS		Hex. Head Bolt				Mass (lb)			
		Flange Only	Complete Unit (2)		Size	G centers (in)	Size	F centers (in)	C (in)	D (in)	E (in)	L (in)	Flange Only	Complete Unit
1 11/16	01E B 111	DF02	01E BCDF 111 AT	6 1/2	M12	4 7/16	1/2"	4 5/8	2	4 3/4	1/2	4	8.8	17.6
1 3/4	01E B 112	DF02	01E BCDF 112 AT	6 1/2	M12	4 7/16	1/2"	4 5/8	2	4 3/4	1/2	4	8.8	17.6
1 15/16	01E B 115	DF02	01E BCDF 115 AT	6 1/2	M12	4 7/16	1/2"	4 5/8	2	4 3/4	1/2	4	8.8	17.6
2	01E B 200	DF02	01E BCDF 200 AT	6 1/2	M12	4 7/16	1/2"	4 5/8	2	4 3/4	1/2	4	8.8	17.6
2 3/16	01E B 203	DF03	01E BCDF 203 AT	7 1/4	M16	5 3/8	5/8"	5 9/16	2 3/16	5 3/4	5/8	4 1/4	12.3	23.3
2 1/4	01E B 204	DF03	01E BCDF 204 AT	7 1/4	M16	5 3/8	5/8"	5 9/16	2 3/16	5 3/4	5/8	4 1/4	12.3	23.3
2 7/16	01E B 207	DF03	01E BCDF 207 AT	7 1/4	M16	5 3/8	5/8"	5 9/16	2 3/16	5 3/4	5/8	4 1/4	12.3	23.3
2 1/2	01E B 208	DF03	01E BCDF 208 AT	7 1/4	M16	5 3/8	5/8"	5 9/16	2 3/16	5 3/4	5/8	4 1/4	12.3	23.3
2 11/16	01E B 211	DF04	01E BCDF 211 AT	8 5/8	M20	6 7/16	3/4"	6 3/4	2 3/8	7	5/8	4 5/8	18.7	36.3
2 3/4	01E B 212	DF04	01E BCDF 212 AT	8 5/8	M20	6 7/16	3/4"	6 3/4	2 3/8	7	5/8	4 5/8	18.7	36.3
2 15/16	100 B 215	DF03	100 BCDF 215 AT	7 1/4	M16	5 3/8	5/8"	5 9/16	2 3/16	5 3/4	5/8	4 1/4	12.3	22.8
	01E B 215	DF04	01E BCDF 215 AT	8 5/8	M20	6 7/16	3/4"	6 3/4	2 3/8	7	5/8	4 5/8	18.7	36.3
3	100 B 300	DF03	100 BCDF 300 AT	7 1/4	M16	5 3/8	5/8"	5 9/16	2 3/16	5 3/4	5/8	4 1/4	12.3	22.9
	01E B 300	DF04	01E BCDF 300 AT	8 5/8	M20	6 7/16	3/4"	6 3/4	2 3/8	7	5/8	4 5/8	18.7	36.3
3 7/16	100 B 307	DF04	100 BCDF 307 AT	8 5/8	M20	6 7/16	3/4"	6 3/4	2 3/8	7	5/8	4 5/8	18.7	35.2

- 1) For full references of bearings and cartridges see pages 36 to 40
- 2) Add 'EX' or 'GR' to complete unit reference for expansion type or fixed type respectively, e.g.: 01E BCDF 207 EX AT

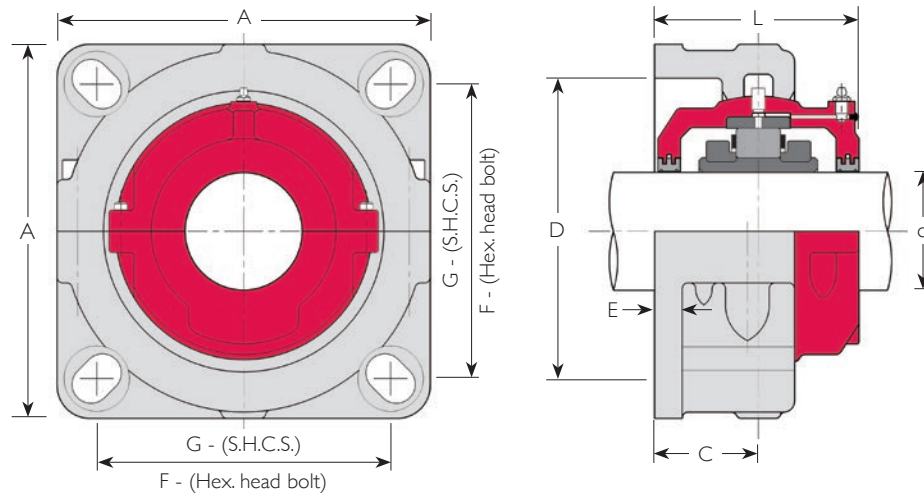

Shaft Diameter d (mm)	Bearing Reference (1)	References		A (mm)	SHCS		Hex. Head Bolt		C (mm)	D (mm)	E (mm)	L (mm)	Mass (kg)	
		Flange Only	Complete Unit (2)		Size	G centers (mm)	Size	F centers (mm)					Flange Only	Complete Unit
45	01E B 45M	DF02	01E BCDF 45M AT	165	M12	114	1/2"	118	52	120	13	101	4	8.0
50	01E B 50M	DF02	01E BCDF 50M AT	165	M12	114	1/2"	118	52	120	13	101	4	8.0
55	01E B 55M	DF03	01E BCDF 55M AT	184	M16	136	5/8"	141	55	146	16	107	5.6	10.6
60	01E B 60M	DF03	01E BCDF 60M AT	184	M16	136	5/8"	141	55	146	16	107	5.6	10.6
65	01E B 65M	DF03	01E BCDF 65M AT	184	M16	136	5/8"	141	55	146	16	107	5.6	10.6
70	01E B 70M	DF04	01E BCDF 70M AT	217	M20	164	3/4"	171	60	178	16	117	8.5	16.5
75	100 B 75M	DF03	100 BCDF 75M AT	184	M16	136	5/8"	141	55	146	16	107	5.6	10.4
	01E B 75M	DF04	01E BCDF 75M AT	217	M20	164	3/4"	171	60	178	16	117	8.5	16.5
85	01E B 85	DF04	01E BCDF 85M AT	217	M20	164	3/4"	171	60	178	16	117	8.5	17.6

1) For full references of bearings and cartridges see pages 54 to 56

2) Add 'EX' or 'GR' to complete unit reference for expansion type or fixed type respectively, e.g.: 01E BCDF 50M EX AT

Hanger units are a compact means of supporting the shafts of screw conveyors and similar equipment.

The bearing is mounted directly into a split gray iron housing ('hanger') with a threaded boss, to allow suspension from the

conveyor cross-bracing. A swivel fixing at the cross-bracing joint is recommended to provide for alignment of the bearing.

Hangers are only suitable for housing expansion ('EX') type bearings.

STANDARD HANGER

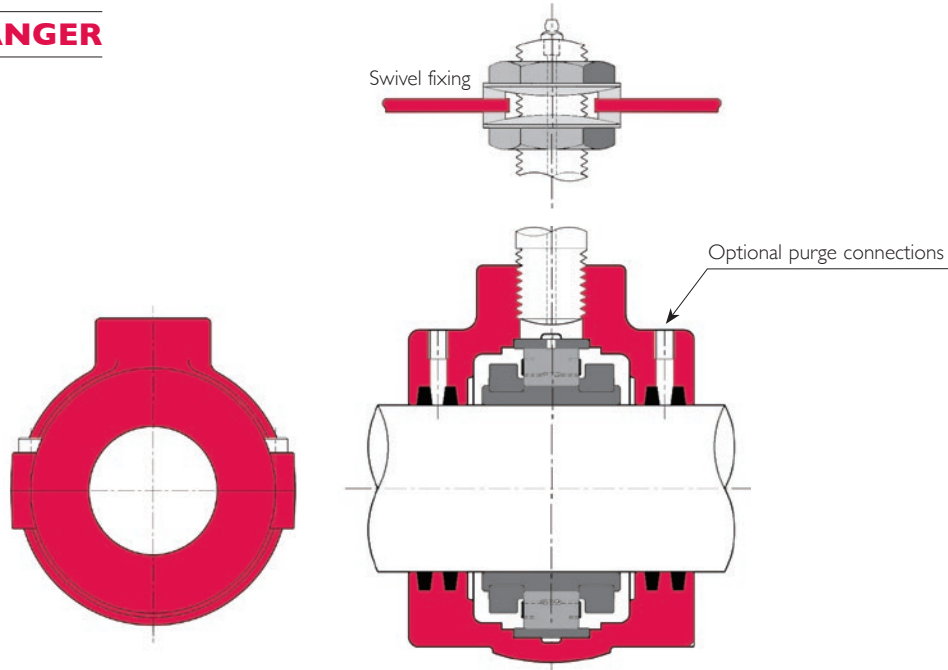

Double felt seals are supplied as standard. The standard seal grooves are also able to accommodate rubber lip seals or high temperature packing. A tapped hole in communication with the space between the seal grooves at each end of the housing is optionally provided. This is for connection to either a grease supply or an air supply for regular or continuous purging of the

seals.

Another option is for the housing end bores to be machined, to take heavy duty lip seals as illustrated below. The length on shaft of these units may be slightly greater than standard; details will be supplied on request.

HANGER WITH HEAVY DUTY LIP SEALS

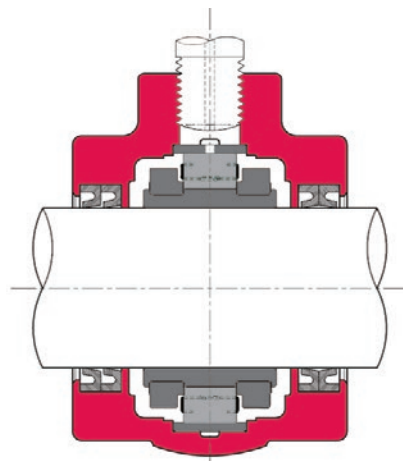

It is recommended that our technical department is contacted in order to obtain a recommendation for the sealing of each hanger unit application.

Lubrication points are not fitted to hangers as standard, with provision for lubrication of the bearing usually made through the suspension rod. Continuous grease feed is sometimes desirable.

The standard type of hanger has a single threaded boss for suspension from above, by a single rod to minimize the obstruction to material flow in scroll conveyors. For applications where it is desired to locate the housing by rods from above and below, a double boss type is available.

DOUBLE BOSS HANGER

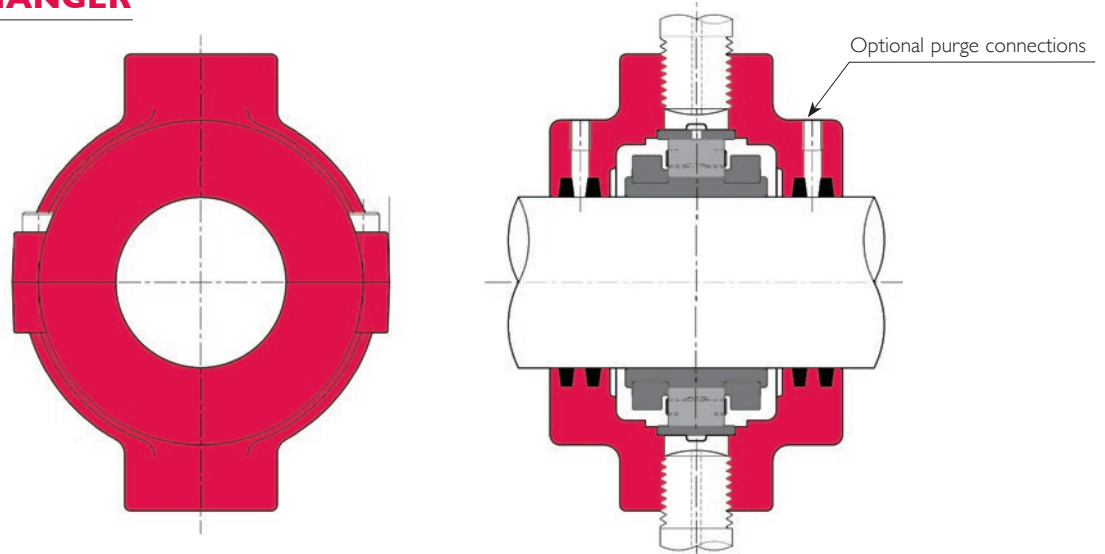

A further type of hanger has three threaded bosses disposed at 120 degree intervals for location by three rods.

TRIPLE BOSS HANGER

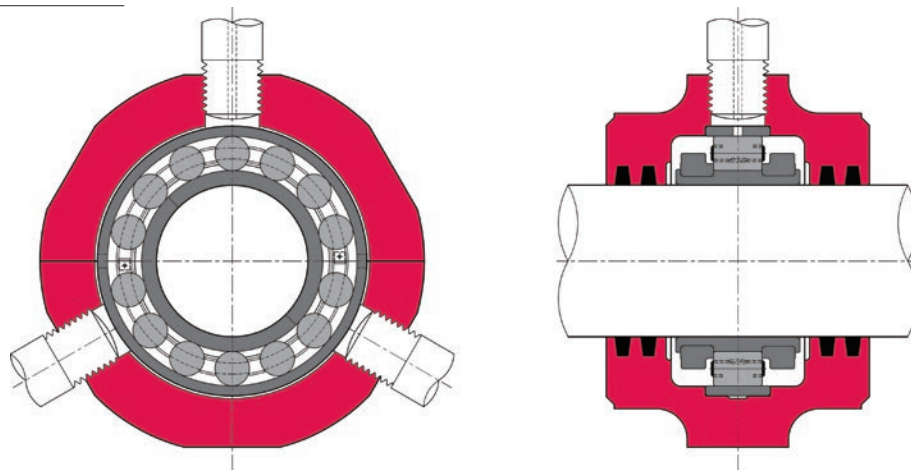

STANDARD

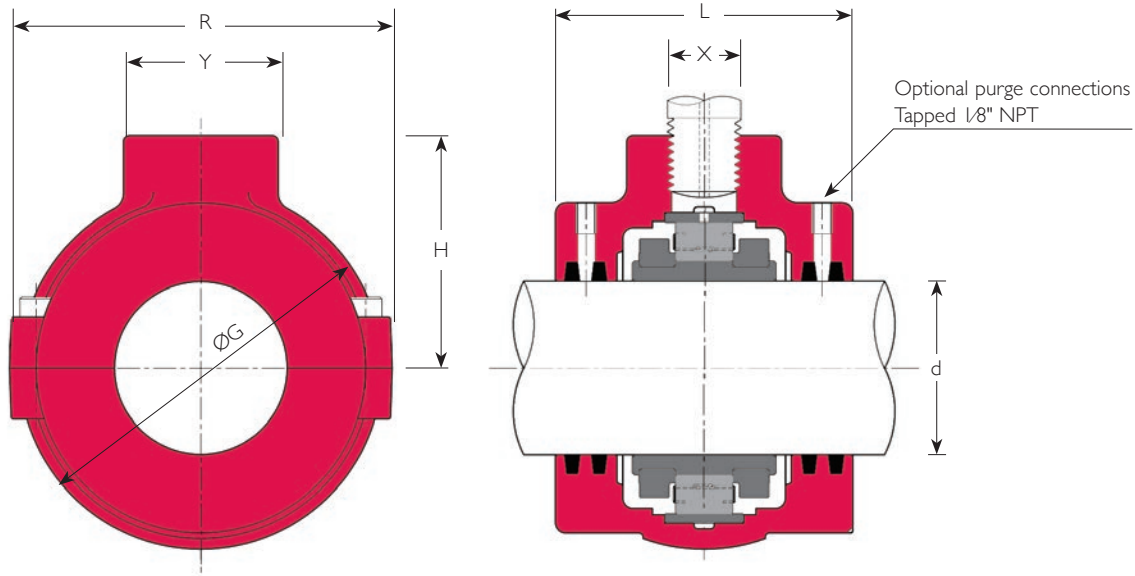

Shaft Diameter d (in)	References			G (in)	L (in)	H (in)	X (in)	Y (in)	R (in)	Mass (lb)	
	Bearing	Hanger Only (I)	Complete Unit (I)							Hanger Only	Complete Unit
1 1/4	01 B 104 EX	01 H 104	01 BH 104	3 15/16	4 1/4	2 5/8	1" - 8 UNC	2	4 1/8	5.7	8.4
1 1/2	01 B 108 EX	01 H 108	01 BH 108	3 15/16	4 1/4	2 5/8	1" - 8 UNC	2	4 1/8	5.7	8.4
1 11/16	01E B 111 EX	01 H 111	01E BH 111	4 5/8	4 1/4	3	1" - 8 UNC	2	4 3/4	9.0	12.3
1 3/4	01E B 112 EX	01 H 112	01E BH 112	4 5/8	4 1/4	3	1" - 8 UNC	2	4 3/4	9.0	12.3
1 15/16	01E B 115 EX	01 H 115	01E BH 115	4 5/8	4 1/4	3	1" - 8 UNC	2	4 3/4	9.0	12.3
2	01E B 200 EX	01 H 200	01E BH 200	4 5/8	4 1/4	3	1" - 8 UNC	2	4 3/4	9.0	12.3
2 3/16	01E B 203 EX	01 H 203	01E BH 203	5 1/4	4 1/4	3 1/4	1" - 8 UNC	2	5 3/8	10.3	14.3
2 1/4	01E B 204 EX	01 H 204	01E BH 204	5 1/4	4 1/4	3 1/4	1" - 8 UNC	2	5 3/8	10.3	14.3
2 7/16	01E B 207 EX	01 H 207	01E BH 207	5 1/4	4 1/4	3 1/4	1" - 8 UNC	2	5 3/8	10.3	14.3
2 1/2	01E B 208 EX	01 H 208	01E BH 208	5 1/4	4 1/4	3 1/4	1" - 8 UNC	2	5 3/8	10.3	14.3
2 11/16	01E B 211 EX	01 H 211	01E BH 211	6 1/4	5 1/4	3 5/8	1" - 8 UNC	2	6 3/8	17.6	23.1
2 3/4	01E B 212 EX	01 H 212	01E BH 212	6 1/4	5 1/8	3 5/8	1" - 8 UNC	2	6 3/8	17.6	23.1
2 15/16	100 B 215 EX	100 H 215	100 BH 215	5 1/4	4 1/4	3 1/4	1" - 8 UNC	2	6 3/8	10.3	13.0
	01E B 215 EX	01 H 215	01E BH 215	6 1/4	5 1/8	3 5/8				17.6	23.1

I) For grease/air purge points to seals add 'AP' to reference, e.g.: 100 H 307 AP or 100 BH 307 AP

For double boss type add 'DOUBLE BOSS' to reference, e.g.: 100 H 307 DOUBLE BOSS or 100 BH 307 DOUBLE BOSS

For double boss type with purge points to seals add 'DOUBLE BOSS AP' to reference, e.g.: 100 H 307 DOUBLE BOSS AP or 100 BH307 DOUBLE BOSS AP

STANDARD AND DOUBLE BOSS

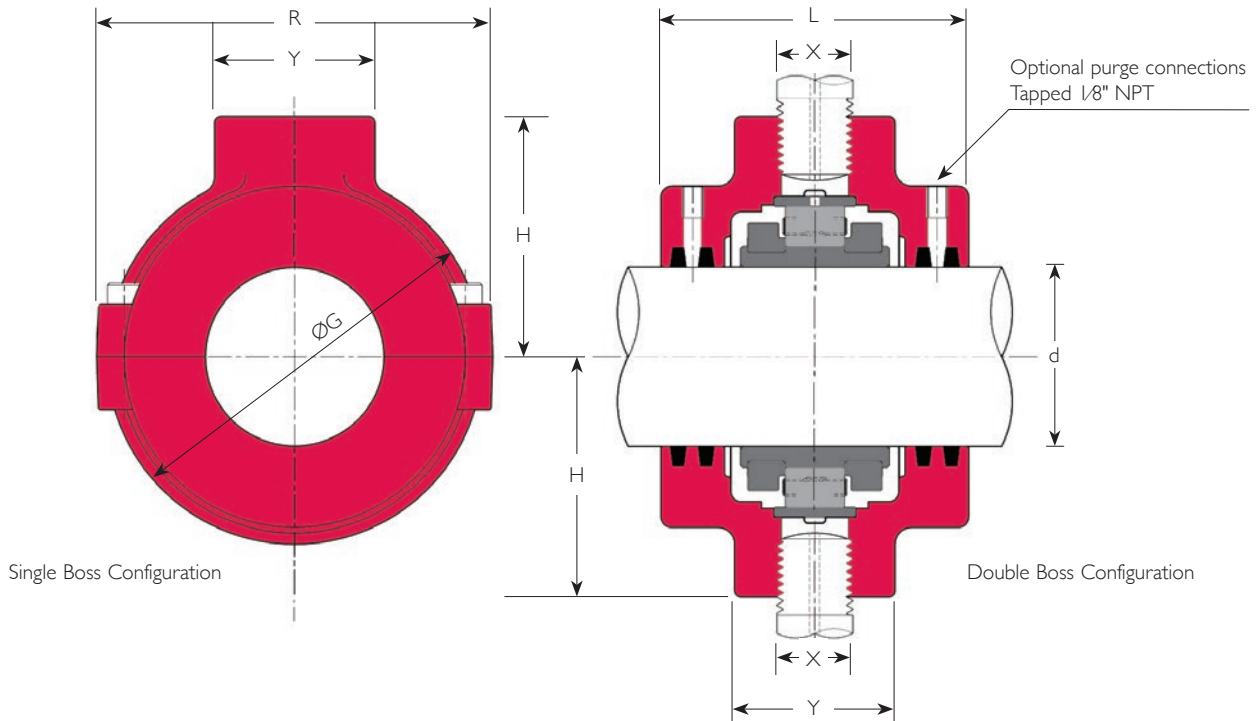

Shaft Diameter d (in)	References			G (in)	L (in)	H (in)	X (in)	Y (in)	R (in)	Mass (lb)	
	Bearing	Hanger Only (I)	Complete Unit (I)							Hanger Only	Complete Unit
3	100 B 300 EX	100 H 300	100 BH 300	5 1/4	4 1/4	3 1/4	1" - 8 UNC	2	6 3/8	10.3	13.0
	01E B 300 EX	01 H 300	01E BH 300	6 1/4	5 1/8	3 5/8	1" - 8 UNC	2		17.6	23.1
3 3/16	01E B 303 EX	01 H 303	01E BH 303	7	5 3/4	4 1/2	1 1/2" - 6 UNC	3	7 3/8	26.4	35.2
3 1/4	01E B 304 EX	01 H 304	01E BH 304	7	5 3/4	4 1/2	1 1/2" - 6 UNC	3	7 3/8	26.4	35.2
3 7/16	100 B 307 EX	100 H 307	100 BH 307	6 1/4	5 1/8	3 5/8	1" - 8 UNC	2	7 3/8	17.6	22.2
	01E B 307 EX	01 H 307	01E BH 307	7	5 3/4	4 1/2	1 1/2" - 6 UNC	3		26.4	35.2
3 1/2	01E B 308 EX	01 H 308	01E BH 308	7	5 3/4	4 1/2	1 1/2" - 6 UNC	3	7 3/8	26.4	35.2
3 11/16	01E B 311 EX	01 H 311	01E BH 311	8	6	5	1 1/2" - 6 UNC	3	7 7/8	30.8	44.0
3 3/4	01E B 312 EX	01 H 312	01E BH 312	8	6	5	1 1/2" - 6 UNC	3	7 7/8	30.8	44.0
3 15/16	100 B 315 EX	100 H 315	100 BH 315	7	5 3/4	4 1/2	1 1/2" - 6 UNC	3	7 7/8	26.4	32.6
	01E B 315 EX	01 H 315	01E BH 315	8	6	5	1 1/2" - 6 UNC	3		30.8	44.0
4	100 B 400 EX	100 H 400	100 BH 400	7	5 3/4	4 1/2	1 1/2" - 6 UNC	3	7 7/8	26.4	32.6
	01E B 400 EX	01 H 400	01E BH 400	8	6	5	1 1/2" - 6 UNC	3		30.8	44.0
4 3/16	01E B 403 EX	01 H 403	01E BH 403	9 1/8	6 1/8	5 1/2	1 1/2" - 6 UNC	3	8 3/4	36.1	58.5

These shaft sizes are offered in single and double boss configuration. The single boss is the most common.

STANDARD

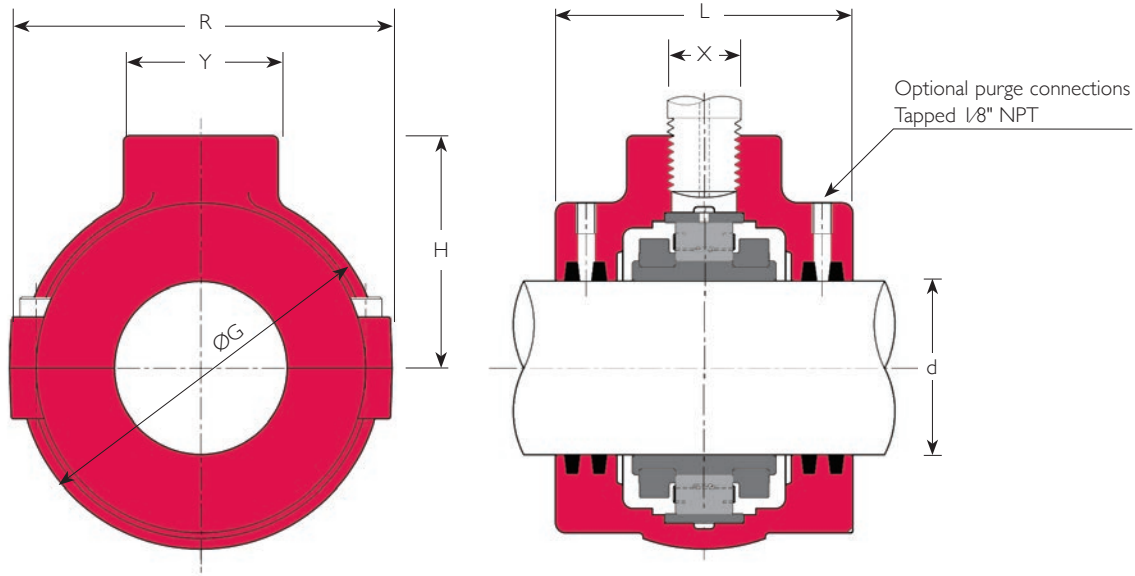

Shaft Diameter d (in)	References			G (in)	L (in)	H (in)	X	Y (in)	R (in)	Mass (lb)	
	Bearing	Hanger Only (I)	Complete Unit (I)							Hanger Only	Complete Unit
4 7/16	100 B 407 EX	100 H 407	100 BH 407	8	6	5	1 1/2" - 6 UNC	3	8 3/4	30.8	40.9
	01 B 407 EX	01 H 407	01 BH 407	9 1/8	6 1/8	5 1/2	1 1/2" - 6 UNC	3		36.1	58.5
4 1/2	100 B 408 EX	100 H 408	100 BH 408	8	6	5	1 1/2" - 6 UNC	3	8 3/4	30.8	40.9
	01 B 408 EX	01 H 408	01 BH 408	9 1/8	6 1/8	5 1/2	1 1/2" - 6 UNC	3		36.1	58.5
4 15/16	100 B 415 EX	100 H 415	100 BH 415	9 1/8	6 1/8	5 1/2	1 1/2" - 6 UNC	3	9 3/8	36.1	52.4
	01 B 415 EX	01 H 415	01 BH 415	10 7/8	6 3/8	6 1/8	1 1/2" - 6 UNC	3		49.1	77.2
5	100 B 500 EX	100 H 500	100 BH 500	9 1/8	6 1/8	5 1/2	1 1/2" - 6 UNC	3	9 3/8	36.1	52.4
	01 B 500 EX	01 H 500	01 BH 500	10 7/8	6 3/8	6 1/8	1 1/2" - 6 UNC	3		49.1	77.2
5 3/16	01 B 503 EX	01 H 503	01 BH 503	11	6 1/4	6 5/16	1 1/2" - 6 UNC	3	10 3/8	46.0	79.0
5 7/16	100 B 507 EX	100 H 507	100 BH 507	10 7/8	6 3/8	6 1/8	1 1/2" - 6 UNC	3	10 3/8	49.1	69.5
	01 B 507 EX	01 H 507	01 BH 507	11	6 1/4	6 5/16	1 1/2" - 6 UNC	3		46.0	79.0
5 1/2	100 B 508 EX	100 H 508	100 BH 508	10 7/8	6 3/8	6 1/8	1 1/2" - 6 UNC	3	10 3/8	49.1	69.5
	01 B 508 EX	01 H 508	01 BH 508	11	6 1/4	6 5/16	1 1/2" - 6 UNC	3		46.0	79.0
5 15/16	100 B 515 EX	100 H 515	100 BH 515	11	6 1/4	6 5/16	1 1/2" - 6 UNC	3	10 3/8	46.0	68.9
6	100 B 600 EX	100 H 600	100 BH 600	11	6 1/4	6 5/16	1 1/2" - 6 UNC	3	10 3/8	46.0	68.9

I) For grease/air purge points to seals add 'AP' to reference, e.g.: 100 H 407 AP or 100 BH 407 AP

For double boss type add 'DOUBLE BOSS' to reference, e.g.: 100 H 407 DOUBLE BOSS or 100 BH 407 DOUBLE BOSS

For double boss type with purge points to seals add 'DOUBLE BOSS AP' to reference, e.g.: 100 H 407 DOUBLE BOSS AP or 100 BH 407 DOUBLE BOSS AP

DOUBLE BOSS

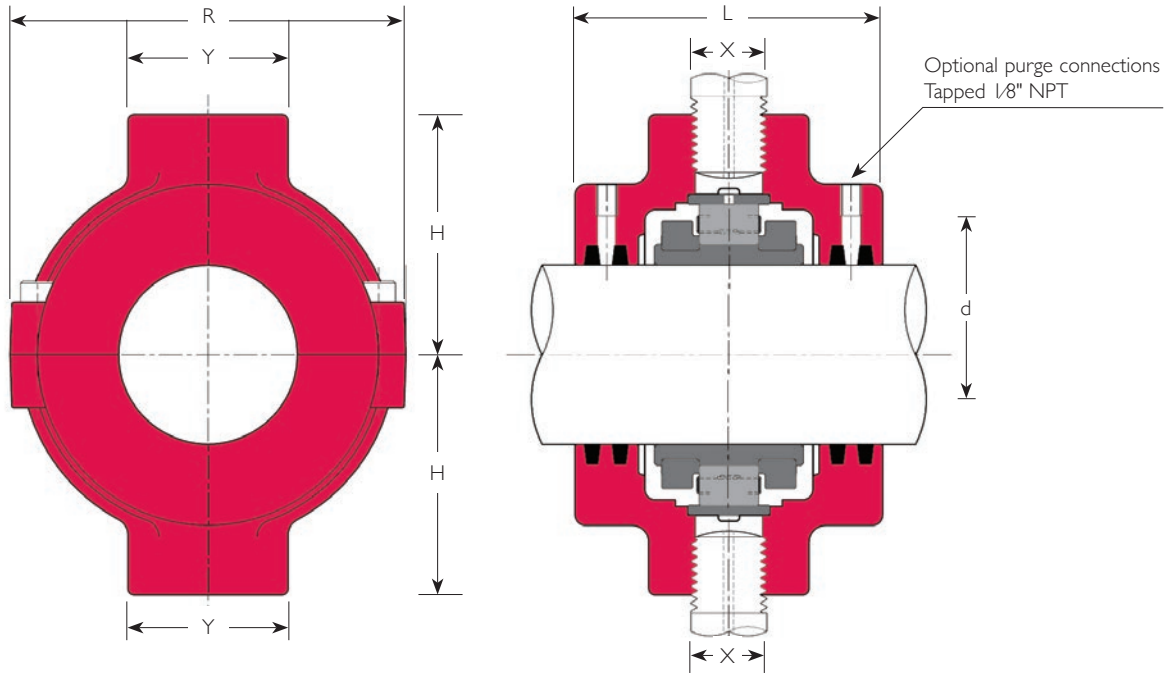

Shaft Diameter d (in)	References			G (in)	L (in)	H (in)	X	Y (in)	R (in)	Mass (lb)	
	Bearing	Hanger Only (I)	Complete Unit (I)							Hanger Only	Complete Unit
4 7/16	100 B 407 EX	100 H 407	100 BH 407	8	6	5	1 1/2" - 6 UNC	3	8 3/4	30.8	40.9
	01 B 407 EX	01 H 407	01 BH 407	9 1/8	6 1/8	5 1/2	1 1/2" - 6 UNC	3		36.1	58.5
4 1/2	100 B 408 EX	100 H 408	100 BH 408	8	6	5	1 1/2" - 6 UNC	3	8 3/4	30.8	40.9
	01 B 408 EX	01 H 408	01 BH 408	9 1/8	6 1/8	5 1/2	1 1/2" - 6 UNC	3		36.1	58.5
4 15/16	100 B 415 EX	100 H 415	100 BH 415	9 1/8	6 1/8	5 1/2	1 1/2" - 6 UNC	3	9 3/8	36.1	52.4
	01 B 415 EX	01 H 415	01 BH 415	10 7/8	6 3/8	6 1/8	1 1/2" - 6 UNC	3		49.1	77.2
5	100 B 500 EX	100 H 500	100 BH 500	9 1/8	6 1/8	5 1/2	1 1/2" - 6 UNC	3	9 3/8	36.1	52.4
	01 B 500 EX	01 H 500	01 BH 500	10 7/8	6 3/8	6 1/8	1 1/2" - 6 UNC	3		49.1	77.2
5 3/16	01 B 503 EX	01 H 503	01 BH 503	11	6 1/4	6 5/16	1 1/2" - 6 UNC	3	10 3/8	46.0	79.0
5 7/16	100 B 507 EX	100 H 507	100 BH 507	10 7/8	6 3/8	6 1/8	1 1/2" - 6 UNC	3	10 3/8	49.1	69.5
	01 B 507 EX	01 H 507	01 BH 507	11	6 1/4	6 5/16	1 1/2" - 6 UNC	3		46.0	79.0
5 1/2	100 B 508 EX	100 H 508	100 BH 508	10 7/8	6 3/8	6 1/8	1 1/2" - 6 UNC	3	10 3/8	49.1	69.5
	01 B 508 EX	01 H 508	01 BH 508	11	6 1/4	6 5/16	1 1/2" - 6 UNC	3		46.0	79.0
5 15/16	100 B 515 EX	100 H 515	100 BH 515	11	6 1/4	6 5/16	1 1/2" - 6 UNC	3	10 3/8	46.0	68.9
6	100 B 600 EX	100 H 600	100 BH 600	11	6 1/4	6 5/16	1 1/2" - 6 UNC	3	10 3/8	46.0	68.9

- I) For grease/air purge points to seals add 'AP' to reference, e.g.: 100 H 407 AP or 100 BH 407 AP
- For double boss type add 'DOUBLE BOSS' to reference, e.g.: 100 H 407 DOUBLE BOSS or 100 BH 407 DOUBLE BOSS
- For double boss type with purge points to seals add 'DOUBLE BOSS AP' to reference, e.g.: 100 H 407 DOUBLE BOSS AP or 100 BH 407 DOUBLE BOSS AP

STANDARD

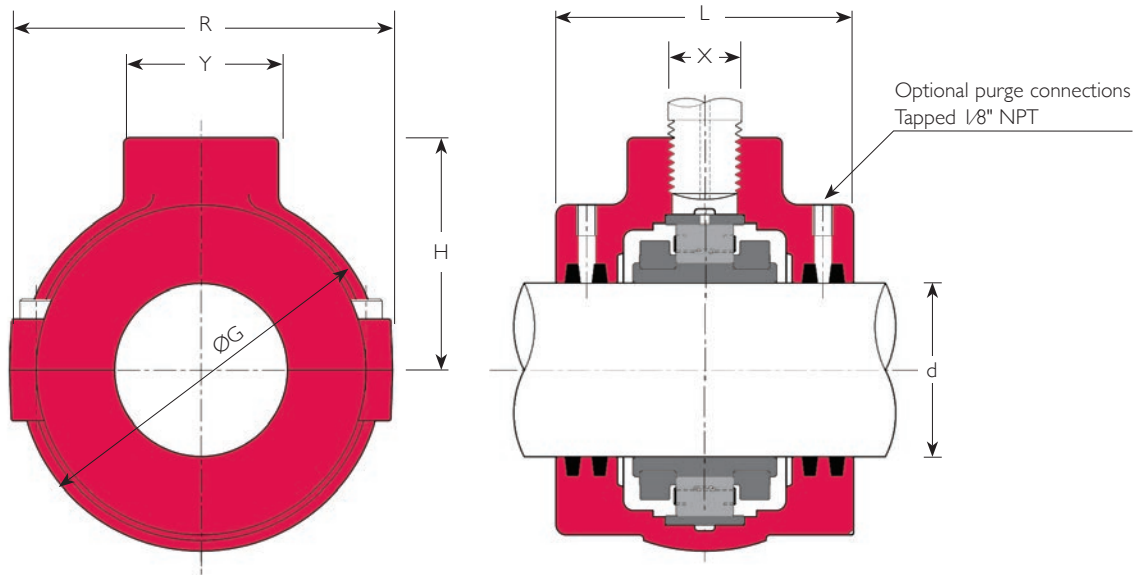

Shaft Diameter d (mm)	References			G (mm)	L (mm)	H (mm)	X	Y (mm)	R (mm)	Mass (kg)	
	Bearing	Hanger Only (I)	Complete Unit (I)							Hanger Only	Complete Unit
40	01E B 40M EX	01 H 40M	01 BH 40M EX	100	108	66	M30	50	106	2.6	3.8
50	01E B 50M EX	01 H 50M	01E BH 50M EX	118	108	76	M30	50	123	4.1	5.6
60	01E B 60M EX	01 H 60M	01E BH 60M EX	134	108	82	M30	50	139	4.7	6.5
65	01E B 65M EX	01 H 65M	01E BH 65M EX	134	108	82	M30	50	139	4.7	6.5
70	01E B 70M EX	01 H 70M	01E BH 70M EX	158	130	92	M30	50	162	8.0	10.5
75	100 B 75M EX	100 H 75M	100 BH 75M EX	134	108	82	M30	50	139	4.7	5.9
	01E B 75M EX	01 H 75M	01E BH 75M EX	158	130	92	M30	50	162	8.0	10.5
80	01E B 80M EX	01 H 80M	01E BH 80M EX	178	146	114	M36	76	188	12.0	16.0
85	100 B 85M EX	100 H 85M	100 BH 85M EX	158	130	92	M30	50	162	8.0	10.1
	01E B 85M EX	01 H 85M	01E BH 85M EX	178	146	114	M36	76	188	12.0	16.0
90	01E B 90M EX	100 H 90M	01E BH 90M EX	178	146	114	M36	76	188	12.0	16.0
100	100 B 100M EX	100 H 100M	100 BH 100M EX	178	146	114	M36	76	188	12.0	14.8
	01E B 100M EX	01 H 100M	01E BH 100M EX	203	152	127	M36	76	204	14.0	20.0

1) For grease/air purge points to seals add 'AP' to reference, e.g.: 100 H 125M AP or 100 BH 125M AP

For double boss type add 'DOUBLE BOSS' to reference, e.g.: 100 H 125M DOUBLE BOSS or 100 BH 307 DOUBLE BOSS

For double boss type with purge points to seals add 'DOUBLE BOSS AP' to reference, e.g.: 100 H 125M DOUBLE BOSS AP or 100 BH 125M DOUBLE BOSS AP

STANDARD AND DOUBLE BOSS

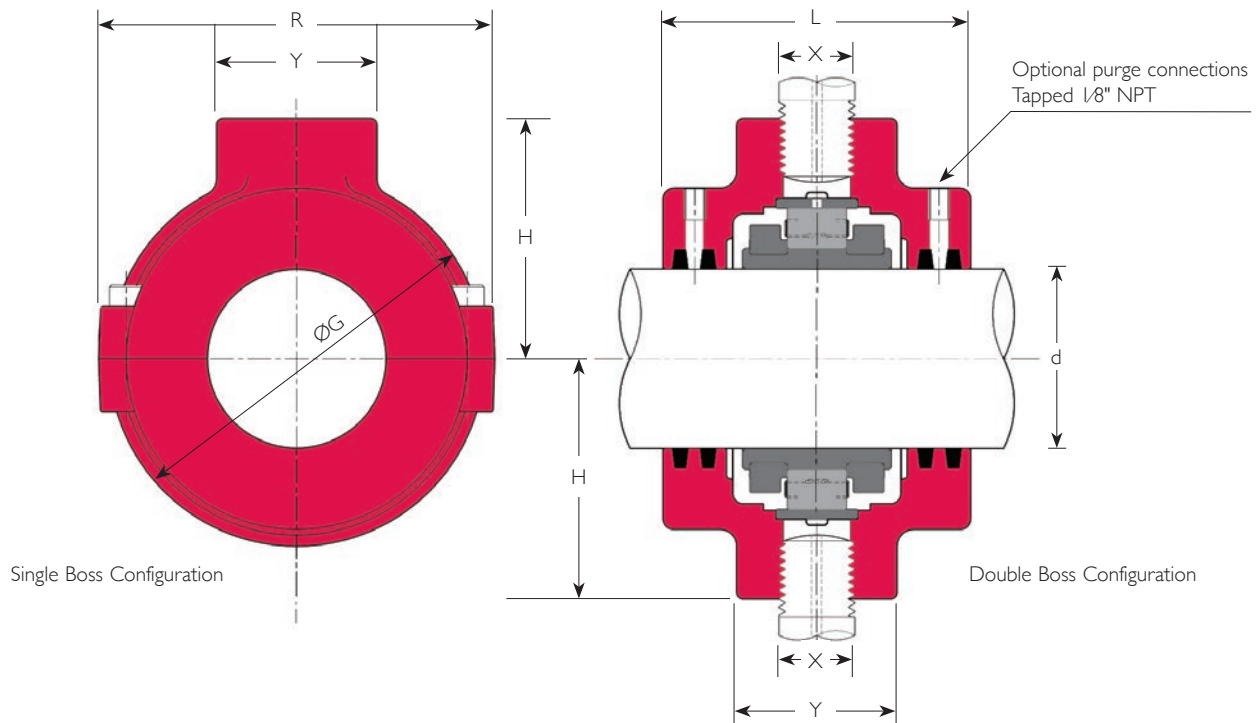

Shaft Diameter d (mm)	References			G (mm)	L (mm)	H (mm)	X	Y (mm)	R (mm)	Mass (kg)	
	Bearing	Hanger Only (I)	Complete Unit (I)							Hanger Only	Complete Unit
105	01E B 105M EX	01 H 105M	01E BH 105M EX	203	152	127	M36	76	204	14.0	20.0
110	100 B 110M EX	100 H 110M	100 BH 110M EX	203	152	127	M36	76	204	14.0	18.6
	01 B 110M EX	01 H 110M	01 BH 110M EX	232	156	140	M36	76	226	16.4	26.6
115	01 B 115M EX	01 H 115M	01 BH 115M EX	232	156	140	M36	76	226	16.4	26.6
120	100 B 120M EX	100 H 120M	100 BH 120M EX	232	156	140	M36	76	226	16.4	23.8
	01 B 120M EX	01 H 120M	01 BH 120M EX	276	162	156	M36	76	238	22.3	35.1
125	01 B 125M EX	01 H 125M	01 BH 125M EX	276	162	156	M36	76	238	22.3	35.1
130	100 B 130M EX	100 H 130M	100 BH 130M EX	232	156	140	M36	76	226	16.4	23.8
	01 B 130M EX	01 H 130M	01 BH 130M EX	276	162	156	M36	76	238	22.3	35.1
135	01 B 135M EX	01 H 135M	01 BH 135M EX	280	158	160	M36	76	264	20.9	35.9
140	100 B 140M EX	100 H 140M	100 BH 140M EX	276	162	156	M36	76	238	22.3	31.6
	01 B 140M EX	01 H 140M	01 BH 140M EX	280	158	160	M36	76	264	20.9	35.9
150	100 B 150M EX	100 H 150M	100 BH 150M EX	280	158	160	M36	76	264	20.9	31.3

These shaft sizes are offered in single and double boss configuration. The single boss is the most common.

Inch-Size Triple Boss Hanger Bearing Units

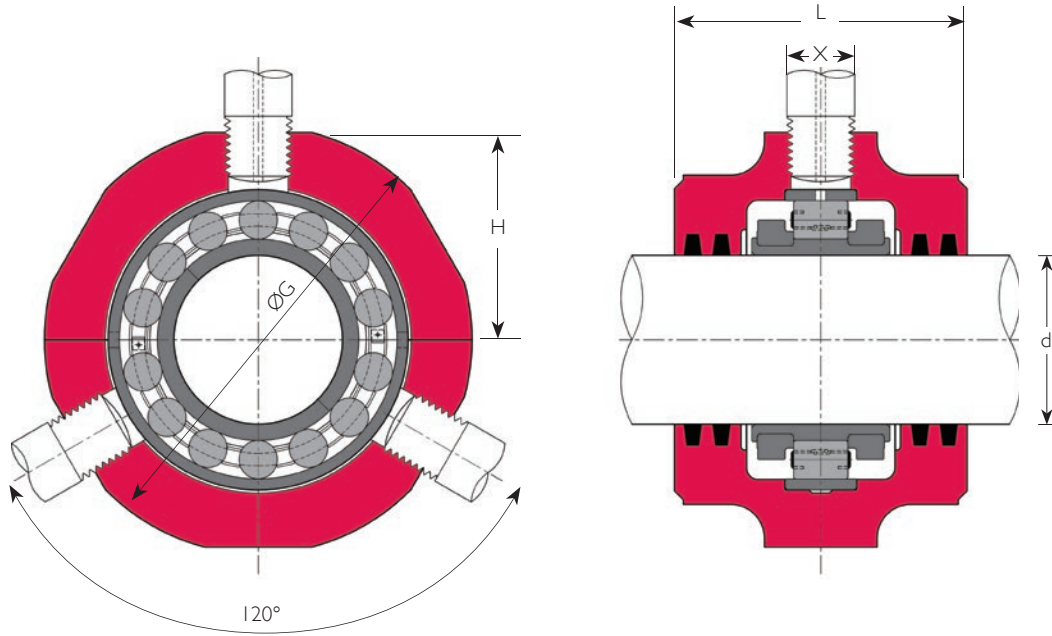

Shaft Diameter d (in)	Bearing	References		G (in)	L (in)	H (in)	X	Mass (lb)	
		Hanger Only	Complete Unit					Hanger Only	Complete Unit
1 15/16	01E B 115 EX	01 H 115 TRIPLE BOSS	01E BH 115 TRIPLE BOSS	6 5/16	4 5/16	3	1" - 8 UNC	14.1	17.4
2	01E B 200 EX	01 H 200 TRIPLE BOSS	01E BH 200 TRIPLE BOSS	6 5/16	4 5/16	3	1" - 8 UNC	14.1	17.4
2 15/16	01E B 215 EX	01 H 215 TRIPLE BOSS	01E BH 215 TRIPLE BOSS	7 1/2	5 1/8	3 5/8	1" - 8 UNC	22.0	27.5
3	01E B 300 EX	01 H 300 TRIPLE BOSS	01E BH 300 TRIPLE BOSS	7 1/2	5 1/8	3 5/8	1" - 8 UNC	22.0	27.5
3 7/16	100 B 307 EX	100 H 307 TRIPLE BOSS	100 BH 307 TRIPLE BOSS	7 1/2	5 1/8	3 5/8	1" - 8 UNC	22.0	26.6
4 7/16	01 B 407 EX	01 H 407 TRIPLE BOSS	01 BH 407 TRIPLE BOSS	11 7/16	6 11/16	5 1/2	1 1/2" - 6 UNC	66.0	88.4
4 1/2	01 B 408 EX	01 H 408 TRIPLE BOSS	01 BH 408 TRIPLE BOSS	11 7/16	6 11/16	5 1/2	1 1/2" - 6 UNC	66.0	88.4
4 15/16	100 B 415 EX	100 H 415 TRIPLE BOSS	100 BH 415 TRIPLE BOSS	11 7/16	6 11/16	5 1/2	1 1/2" - 6 UNC	66.0	82.3
5	100 B 500 EX	100 H 500 TRIPLE BOSS	100 BH 500 TRIPLE BOSS	11 7/16	6 11/16	5 1/2	1 1/2" - 6 UNC	66.0	82.3

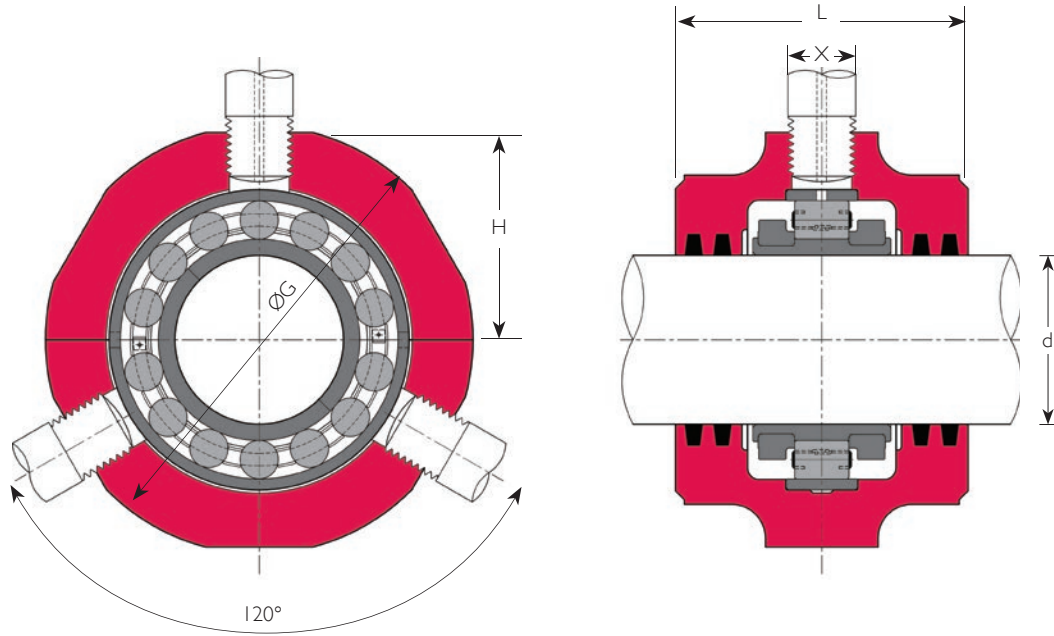

Shaft Diameter d (mm)	Bearing	References		G (mm)	L (mm)	H (mm)	X	Mass (kg)	
		Hanger Only	Complete Unit					Hanger Only	Complete Unit
50	01E B 50M EX	01 H 50M TRIPLE BOSS	01E BH 50M TRIPLE BOSS	160	109	76	M30	6.4	7.9
75	01E B 75M EX	01 H 75M TRIPLE BOSS	01E BH 75M TRIPLE BOSS	190	130	92	M30	10.0	12.5
85	100 B 85M EX	100 H 85M TRIPLE BOSS	100 BH 85M TRIPLE BOSS	190	130	92	M30	10.0	12.1
110	01 B 110M EX	01 H 110M TRIPLE BOSS	01 BH 110M TRIPLE BOSS	290	170	140	M36	30.0	40.2
120	100 B 120M EX	100 H 120M TRIPLE BOSS	100 BH 120M TRIPLE BOSS	290	170	140	M36	30.0	37.4
130	100 B 130M EX	100 H 130M TRIPLE BOSS	100 BH 130M TRIPLE BOSS	290	170	140	M36	30.0	37.4

Cooper take-up units are an efficient means of tensioning the pulleys of conveyors and elevators.

Each take-up unit consists of a Cooper split roller bearing in a swivel cartridge (see page 34) mounted in a cast iron sliding unit. Two basic configurations are available – the 'push' type and 'tension' type as illustrated.

Usually a Cooper take-up will be mounted at each end of the shaft. Up to and including 3½"/90mm bore size the standard arrangement uses two expansion (EX) bearings, with axial location provided by blanking plates and ball thrust bearings. Above 3½"/90mm bore size the standard arrangement uses two fixed (GR) bearings and plain blanking plates. If a through-shaft or different method of axial location is required, please consult our technical department.

**PUSH TYPE UP TO 3 1/2"
ARRANGEMENT**

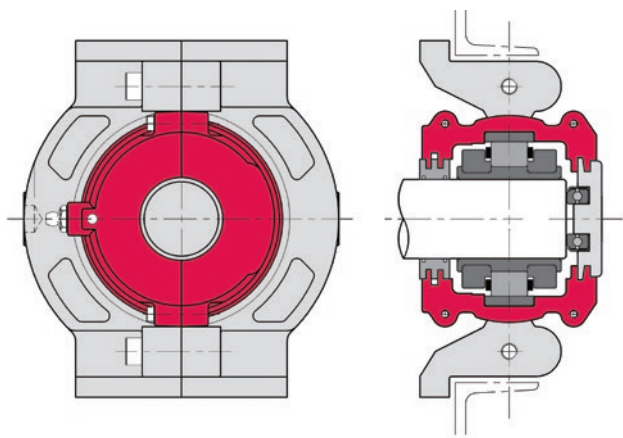

**PUSH TYPE OVER 3 1/2"
ARRANGEMENT**

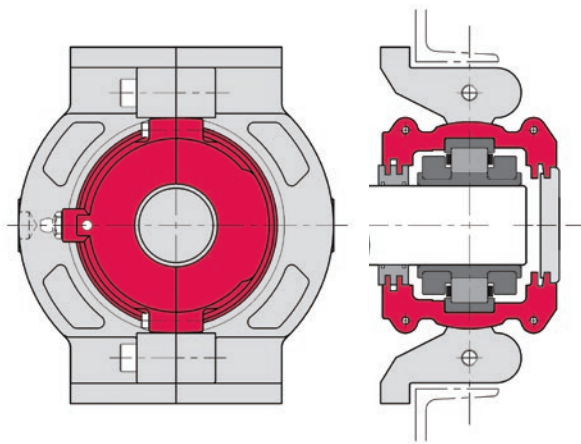

**TENSION TYPE UP TO 3 1/2"
ARRANGEMENT**

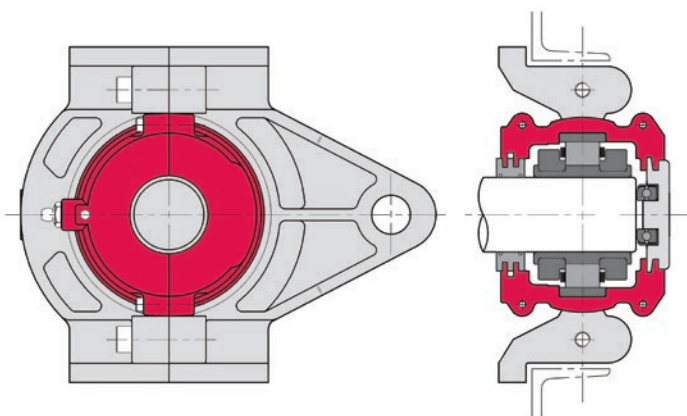

**TENSION TYPE OVER 3 1/2"
ARRANGEMENT**

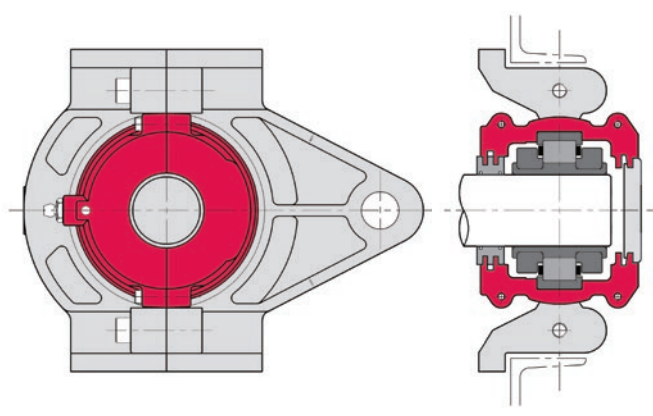

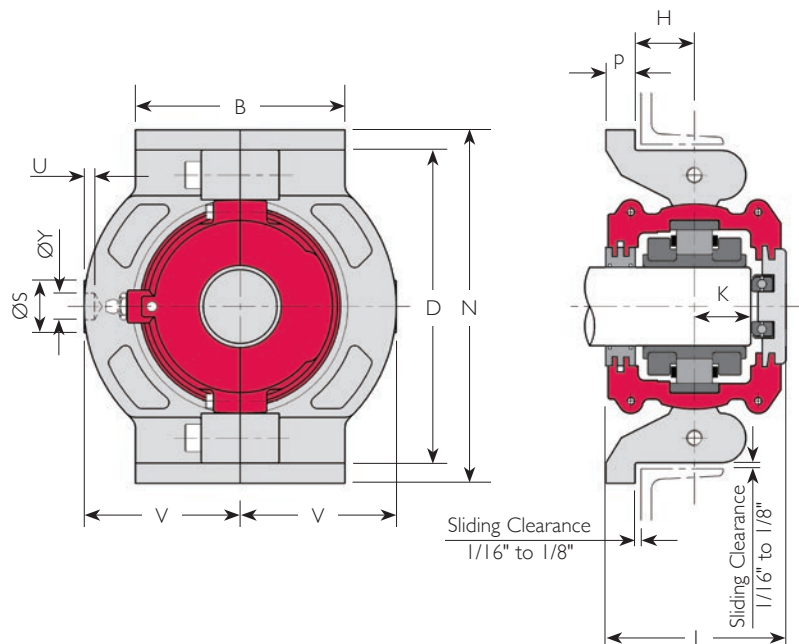

Shaft Diameter d (in)	References		B (in)	N (in)	D (in)	V (in)	K (in)	P (in)	H (in)	L (in)	S (in)	Y (in)	U (in)	Mass (Complete Unit) (lb)
	Complete Unit (I)	Take-Up Housing Only												
1 3/16	01 BCTP 103 AT	TP01	4	6 3/4	6	3	1 1/16	9/16	1 1/8	3 3/8	1	1/2	3/16	13.2
1 1/4	01 BCTP 104 AT	TP01	4	6 3/4	6	3	1 1/16	9/16	1 1/8	3 3/8	1	1/2	3/16	13.2
1 7/16	01 BCTP 107 AT	TP01	4	6 3/4	6	3	1 1/16	9/16	1 1/8	3 3/8	1	1/2	3/16	13.2
1 1/2	01 BCTP 108 AT	TP01	4	6 3/4	6	3	1 1/16	9/16	1 1/8	3 3/8	1	1/2	3/16	13.2
1 11/16	01E BCTP 111 AT	TP02	4 1/2	8	7	3 7/16	1 1/8	5/8	1 1/8	3 7/8	1 1/8	1/2	3/16	19.8
1 3/4	01E BCTP 112 AT	TP02	4 1/2	8	7	3 7/16	1 1/8	5/8	1 1/8	3 7/8	1 1/8	1/2	3/16	19.8
1 15/16	01E BCTP 115 AT	TP02	4 1/2	8	7	3 7/16	1 1/8	5/8	1 1/8	3 7/8	1 1/8	1/2	3/16	19.8
	02 BCTP 115 AT	TP03	5	9 1/4	8	4	1 3/8	13/16	1 1/4	4 1/2	1 1/2	5/8	1/4	26.4
2	01E BCTP 200 AT	TP02	4 1/2	8	7	3 7/16	1 1/8	5/8	1 1/8	3 7/8	1 1/8	1/2	3/16	19.8
	02 BCTP 200 AT	TP03	5	9 1/4	8	4	1 3/8	13/16	1 1/4	4 1/2	1 1/2	5/8	1/4	26.4
2 3/16	01E BCTP 203 AT	TP03	5	9 1/4	8	4	1 3/16	13/16	1 1/4	4 1/8	1 1/2	5/8	1/4	28.6
	02 BCTP 203 AT	TP04	6	10 1/2	9	4 1/2	1 1/2	7/8	1 9/16	4 15/16	1 5/8	5/8	1/4	37.4
2 1/4	01E BCTP 204 AT	TP03	5	9 1/4	8	4	1 3/16	13/16	1 1/4	4 1/8	1 1/2	5/8	1/4	28.6
	02 BCTP 204 AT	TP04	6	10 1/2	9	4 1/2	1 1/2	7/8	1 9/16	4 15/16	1 5/8	5/8	1/4	37.4
2 7/16	01E BCTP 207 AT	TP03	5	9 1/4	8	4	1 3/16	13/16	1 1/4	4 1/8	1 1/2	5/8	1/4	28.6
	02 BCTP 207 AT	TP04	6	10 1/2	9	4 1/2	1 1/2	7/8	1 9/16	4 15/16	1 5/8	5/8	1/4	37.4

1) For radial bearing only reference (for standard arrangement) remove 'CTP' and 'AT' from complete unit reference and add 'EX', e.g. 01E B 207 EX

Ball thrust bearings are usually supplied complete with blanking plate. Refer to page 28

For cartridge reference refer to page 36

Inch-Size Take-Up Push Type Units From 2 1/2" To 4 7/16" Bore Size

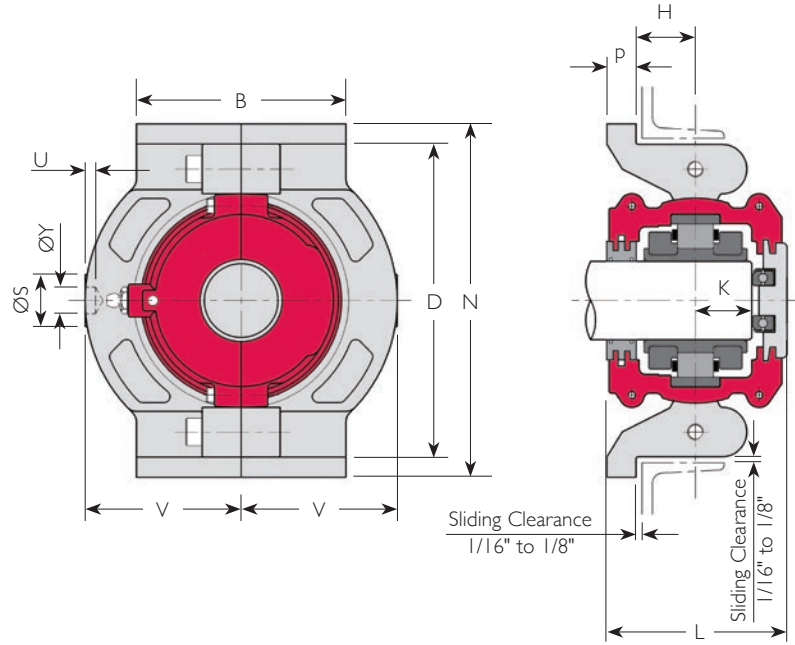

Shaft Diameter d (in)	References		B (in)	N (in)	D (in)	V (in)	K (in)	P (in)	H (in)	L (in)	S (in)	Y (in)	U (in)	Mass (Complete Unit) (lb)
	Complete Unit (I)	Take-Up Housing Only												
2 1/2	01E BCTP 208 AT	TP03	5	9 1/4	8	4	1 3/16	13/16	1 1/4	4 1/8	1 1/2	5/8	1/4	28.6
	02 BCTP 208 AT	TP04	6	10 1/2	9	4 1/2	1 1/2	7/8	1 9/16	4 15/16	1 5/8	5/8	1/4	37.4
2 3/4	01E BCTP 212 AT	TP04	6	10 1/2	9	4 1/2	1 3/8	7/8	1 9/16	4 1/2	1 5/8	5/8	1/4	37.4
	02 BCTP 212 AT	TP05	7 1/2	12 1/2	11	5 1/2	1 5/8	7/8	1 9/16	5 1/2	2	5/8	1/4	59.4
2 15/16	100 BCTP 215 AT	TP03	5	9 1/4	8	4	1 3/16	13/16	1 1/4	4 1/8	1 1/2	5/8	1/4	28.6
	01E BCTP 215 AT	TP04	6	10 1/2	9	4 1/2	1 3/8	7/8	1 9/16	4 1/2	1 5/8	5/8	1/4	37.4
	02 BCTP 215 AT	TP05	7 1/2	12 1/2	11	5 1/2	1 5/8	7/8	1 9/16	5 1/2	2	5/8	1/4	59.4
3	100 BCTP 300 AT	TP03	5	9 1/4	8	4	1 3/16	13/16	1 1/4	4 1/8	1 1/2	5/8	1/4	28.6
	01E BCTP 300 AT	TP04	6	10 1/2	9	4 1/2	1 3/8	7/8	1 9/16	4 1/2	1 5/8	5/8	1/4	37.4
	02 BCTP 300 AT	TP05	7 1/2	12 1/2	11	5 1/2	1 5/8	7/8	1 9/16	5 1/2	2	5/8	1/4	59.4
3 3/16	01E BCTP 303 AT	TP05	7 1/2	12 1/2	11	5 1/2	1 9/16	7/8	1 9/16	5 3/8	2	5/8	1/4	59.4
	02 BCTP 303 AT	TP06	8	13 1/2	12	6	1 7/8	7/8	1 11/16	6 1/16	2	3/4	1/4	68.2
3 1/4	01E BCTP 304 AT	TP05	7 1/2	12 1/2	11	5 1/2	1 9/16	7/8	1 9/16	5 3/8	2	5/8	1/4	59.4
	02 BCTP 304 AT	TP06	8	13 1/2	12	6	1 7/8	7/8	1 11/16	6 1/16	2	3/4	1/4	68.2
3 7/16	100 BCTP 307 AT	TP04	6	10 1/2	9	4 1/2	1 3/8	7/8	1 9/16	4 1/2	1 5/8	5/8	1/4	37.4
	01E BCTP 307 AT	TP05	7 1/2	12 1/2	11	5 1/2	1 9/16	7/8	1 9/16	5 3/8	2	5/8	1/4	59.4
	02 BCTP 307 AT	TP06	8	13 1/2	12	6	1 7/8	7/8	1 11/16	6 1/16	2	3/4	1/4	68.2
3 1/2	01E BCTP 308 AT	TP05	7 1/2	12 1/2	11	5 1/2	1 9/16	7/8	1 9/16	5 3/8	2	5/8	1/4	59.4
	02 BCTP 308 AT	TP06	8	13 1/2	12	6	1 7/8	7/8	1 11/16	6 1/16	2	3/4	1/4	68.2

1) For radial bearing only reference (for standard arrangement) remove 'CTP' and 'AT' from complete unit reference and add 'EX', e.g. 01E B 307 EX

Ball thrust bearings are usually supplied complete with blanking plate. Refer to page 28

For cartridge reference refer to pages 38 to 42

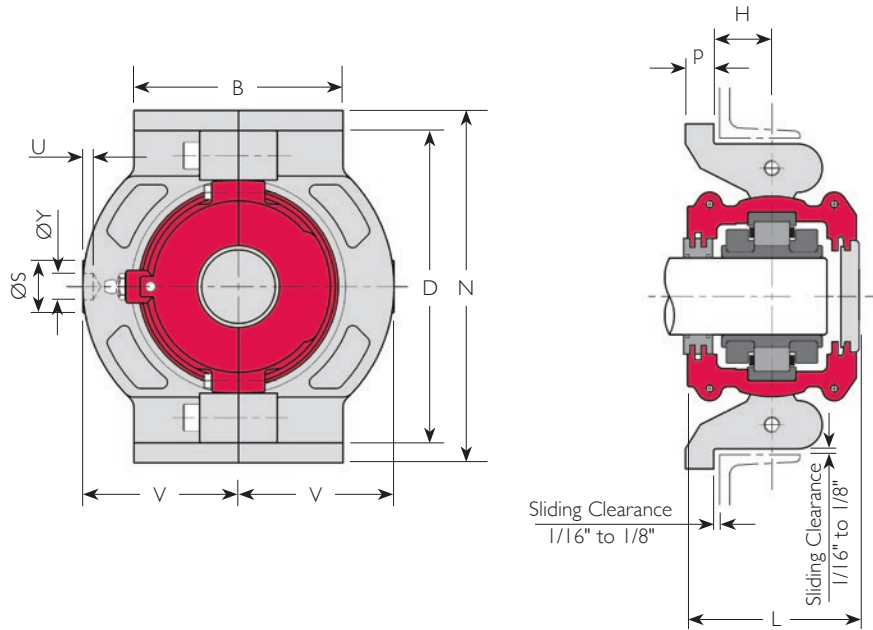

Shaft Diameter d (in)	References		B (in)	N (in)	D (in)	V (in)	P (in)	H (in)	L (in)	S (in)	Y (in)	U (in)	Mass (Complete Unit) (lb)
	Complete Unit (1)	Take-Up Housing Only											
3 11/16	01E BCTP 311 AT	TP06	8	13 1/2	12	6	7/8	1 11/16	5 1/4	2	3/4	1/4	68.2
	02 BCTP 311 AT	TP07	8 1/2	15	13 1/2	6 3/8	7/8	1 7/8	5 3/4	2 3/4	3/4	1/4	101
3 3/4	01E BCTP 312 AT	TP06	8	13 1/2	12	6	7/8	1 11/16	5 1/4	2	3/4	1/4	68.2
	02 BCTP 312 AT	TP07	8 1/2	15	13 1/2	6 3/8	7/8	1 7/8	5 3/4	2 3/4	3/4	1/4	101
3 15/16	100 BCTP 315 AT	TP05	7 1/2	12 1/2	11	5 1/2	7/8	1 9/16	5 3/8	2	5/8	1/4	57.2
	01E BCTP 315 AT	TP06	8	13 1/2	12	6	7/8	1 11/16	5 1/4	2	3/4	1/4	68.2
	02 BCTP 315 AT	TP07	8 1/2	15	13 1/2	6 3/8	7/8	1 7/8	5 3/4	2 3/4	3/4	1/4	101
4	100 BCTP 400 AT	TP05	7 1/2	12 1/2	11	5 1/2	7/8	1 9/16	5 3/8	2	5/8	1/4	57.2
	01E BCTP 400 AT	TP06	8	13 1/2	12	6	7/8	1 11/16	5 1/4	2	3/4	1/4	68.2
	02 BCTP 400 AT	TP07	8 1/2	15	13 1/2	6 3/8	7/8	1 7/8	5 3/4	2 3/4	3/4	1/4	101
4 3/16	01E BCTP 403 AT	TP07	8 1/2	15	13 1/2	6 3/8	7/8	1 7/8	5 9/16	2 3/4	3/4	1/4	101
	02 BCTP 403 AT	TP08	10	16 1/2	15	7 1/2	1	2	6 3/8	3	3/4	1/4	143
4 7/16	100 BCTP 407 AT	TP06	8	13 1/2	12	6	7/8	1 11/16	5 1/4	2	3/4	1/4	63.8
	01 BCTP 407 AT	TP07	8 1/2	15	13 1/2	6 3/8	7/8	1 7/8	5 9/16	2 3/4	3/4	1/4	101
	02 BCTP 407 AT	TP08	10	16 1/2	15	7 1/2	1	2	6 3/8	3	3/4	1/4	143

1) For radial bearing only reference (for standard arrangement) remove 'CTP' and 'AT' from complete unit reference and add 'GR', e.g. 01E B 400 GR
 For cartridge reference refer to pages 40 to 42

Inch-Size Take-Up Push Type Units From 4 1/2" To 6" Bore Size

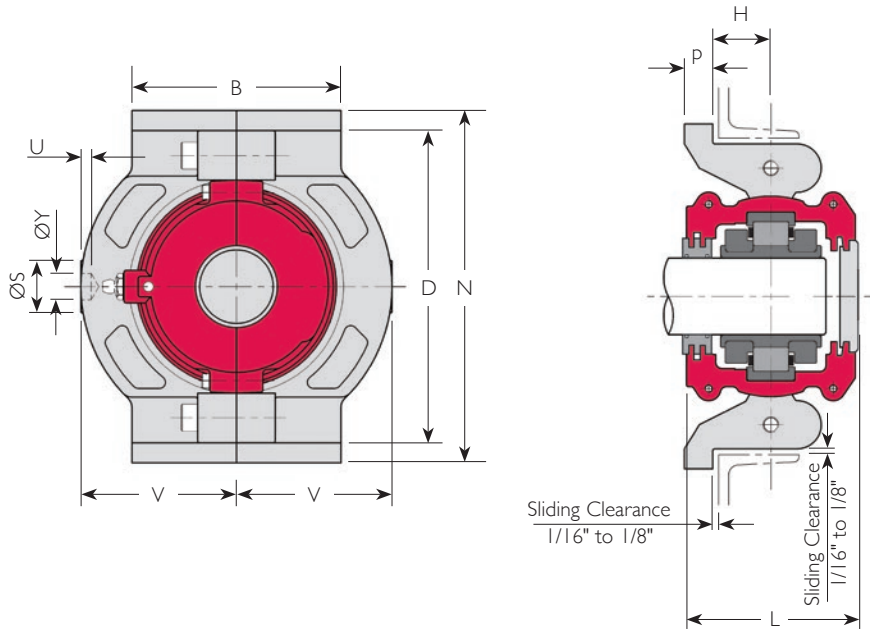

Shaft Diameter d (in)	References		B (in)	N (in)	D (in)	V (in)	P (in)	H (in)	L (in)	S (in)	Y (in)	U (in)	Mass (Complete Unit) (lb)
	Complete Unit (I)	Take-Up Housing Only											
4 1/2	100 BCTP 408 AT	TP06	8	13 1/2	12	6	7/8	1 11/16	5 1/4	2	3/4	1/4	63.8
	01 BCTP 408 AT	TP07	8 1/2	15	13 1/2	6 3/8	7/8	1 7/8	5 9/16	2 3/4	3/4	1/4	101
	02 BCTP 408 AT	TP08	10	16	15	7 1/2	1	2	6 3/8	3	3/4	1/4	143
4 15/16	100 BCTP 415 AT	TP07	8 1/2	15	13 1/2	6 3/8	7/8	1 7/8	5 9/16	2 3/4	3/4	1/4	92.4
	01 BCTP 415 AT	TP08	10	16 1/2	15	7 1/2	1	2	6 1/8	3	3/4	1/4	143
	02 BCTP 415 AT	TP10	10 1/2	18 1/4	16 3/4	8	1	2 1/4	7 1/4	3 1/2	7/8	5/16	200
5	100 BCTP 500 AT	TP07	8 1/2	15	13 1/2	6 3/8	7/8	1 7/8	5 9/16	2 3/4	3/4	1/4	92.4
	01 BCTP 500 AT	TP08	10	16 1/2	15	7 1/2	1	2	6 1/8	3	3/4	1/4	143
	02 BCTP 500 AT	TP10	10 1/2	18 1/4	16 3/4	8	1	2 1/4	7 1/4	3 1/2	7/8	5/16	200
5 3/16	01 BCTP 503 AT	TP09	10 1/2	17 1/4	15 3/4	7 11/16	1	2 1/8	6 5/8	3	7/8	5/16	176
	02 BCTP 503 AT	TP30	11	19 3/4	18 1/4	8 3/4	1	2 3/8	7 3/8	3 1/2	7/8	5/16	240
5 7/16	100 BCTP 507 AT	TP08	10	16 1/2	15	7 1/2	1	2	6 1/8	3	3/4	1/4	132
	01 BCTP 507 AT	TP09	10 1/2	17 1/4	15 3/4	7 11/16	1	2 1/8	6 5/8	3	7/8	5/16	176
	02 BCTP 507 AT	TP30	11	19 3/4	18 1/4	8 3/4	1	2 3/8	7 3/8	3 1/2	7/8	5/16	240

1) For radial bearing only reference (for standard arrangement) remove 'CTP' and 'AT' from complete unit reference and add 'GR', e.g. 01 B 507 GR
 For cartridge reference refer to pages 42 to 44

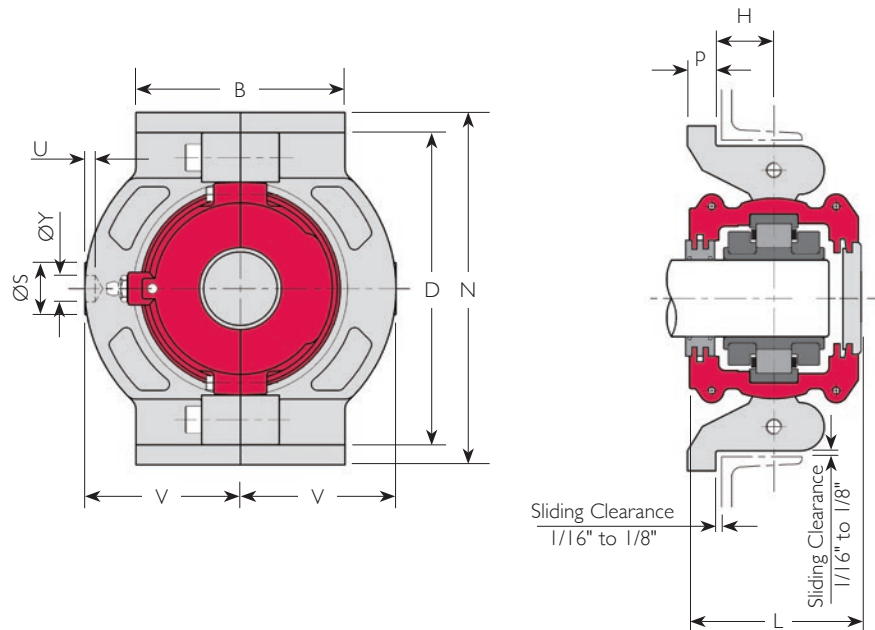

Shaft Diameter d (in)	References		B (in)	N (in)	D (in)	V (in)	P (in)	H (in)	L (in)	S (in)	Y (in)	U (in)	Mass (Complete Unit) (lb)
	Complete Unit (I)	Take-Up Housing Only											
5 1/2	100 BCTP 508 AT	TP08	10	16 1/2	15	7 1/2	1	2	6 1/8	3	3/4	1/4	132
	01 BCTP 508 AT	TP09	10 1/2	17 1/4	15 3/4	7 11/16	1	2 1/8	6 5/8	3	7/8	5/16	176
	02 BCTP 508 AT	TP30	11	19 3/4	18 1/4	8 3/4	1	2 3/8	7 3/8	3 1/2	7/8	5/16	240
5 15/16	100 BCTP 515 AT	TP08	10 1/2	17 1/4	15 3/4	7 11/16	1	2 1/8	6 5/8	3	7/8	5/16	161
	01 BCTP 515 AT	TP09	10 1/2	18 1/4	16 3/4	8	1	2 1/4	6 7/8	3 1/2	7/8	5/16	200
	02 BCTP 515 AT	TP31	12	20 3/4	19 1/4	9 1/4	1	2 1/2	8	3 1/2	1	3/8	240
6	100 BCTP 600 AT	TP09	10 1/2	17 1/4	15 3/4	7 11/16	1	2 1/8	6 5/8	3	7/8	5/16	161
	01 BCTP 600 AT	TP10	10 1/2	18 1/4	16 3/4	8	1	2 1/4	6 7/8	3 1/2	7/8	5/16	200
	02 BCTP 600 AT	TP31	12	20 3/4	19 1/4	9 1/4	1	2 1/2	8	3 1/2	1	3/8	240

Inch-Size Take-Up Tension Type Units From 1 3/16" To 2 15/16" Bore Size

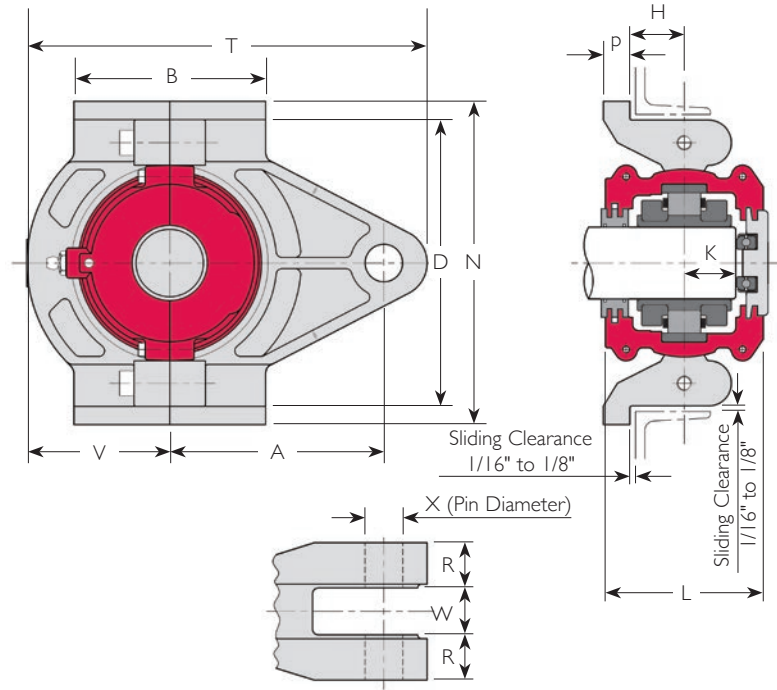

Shaft Diameter d (in)	References		B (in)	N (in)	D (in)	A (in)	T (in)	X (in)	V (in)	K (in)	P (in)	H (in)	W (in)	R (in)	L (in)	Mass (Complete Unit) (lb)
	Complete Unit (1)	Take-Up Housing Only														
1 3/16	01 BCTT 103 AT	TT01	4	6 3/4	6	4 1/2	8 1/2	3/4	3	1 1/16	9/16	1 1/8	1	15/16	3 3/8	15.4
1 1/4	01 BCTT 104 AT	TT01	4	6 3/4	6	4 1/2	8 1/2	3/4	3	1 1/16	9/16	1 1/8	1	15/16	3 3/8	15.4
1 7/16	01 BCTT 107 AT	TT01	4	6 3/4	6	4 1/2	8 1/2	3/4	3	1 1/16	9/16	1 1/8	1	15/16	3 3/8	15.4
1 1/2	01 BCTT 108 AT	TT01	4	6 3/4	6	4 1/2	8 1/2	3/4	3	1 1/16	9/16	1 1/8	1	15/16	3 3/8	15.4
1 11/16	01E BCTT 111 AT	TT02	4 1/2	8	7	5	9 1/2	15/16	3 7/16	1 1/8	5/8	1 1/8	1	1	3 7/8	22.0
1 3/4	01E BCTT 112 AT	TT02	4 1/2	8	7	5	9 1/2	15/16	3 7/16	1 1/8	5/8	1 1/8	1	1	3 7/8	22.0
1 15/16	01E BCTT 115 AT	TT02	4 1/2	8	7	5	9 1/2	15/16	3 7/16	1 1/8	5/8	1 1/8	1	1	3 7/8	22.0
	02 BCTT 115 AT	TT03	5	9 1/4	8	5 3/4	11	15/16	4	1 3/8	13/16	1 1/4	1 3/16	1 1/8	4 1/2	28.6
2	01E BCTT 200 AT	TT02	4 1/2	8	7	5	9 1/2	15/16	3 7/16	1 1/8	5/8	1 1/8	1	1	3 7/8	22.0
	02 BCTT 200 AT	TT03	5	9 1/4	8	5 3/4	11	15/16	4	1 3/8	13/16	1 1/4	1 3/16	1 1/8	4 1/2	28.6
2 3/16	01E BCTT 203 AT	TT03	5	9 1/4	8	5 3/4	11	15/16	4	1 3/16	13/16	1 1/4	1 3/16	1 1/8	4 1/2	28.6
	02 BCTT 203 AT	TT04	6	10 1/2	9	6 1/4	12	15/16	4 1/2	1 1/2	7/8	1 9/16	1 3/16	1 1/4	4 15/16	41.8

1) For radial bearing only reference (for standard arrangement) remove 'CTT' and 'AT' from complete unit reference and add 'EX', e.g. 01E B 207 EX

Ball thrust bearings are usually supplied complete with blanking plate. Refer to page 28

For cartridge reference refer to pages 36 to 38

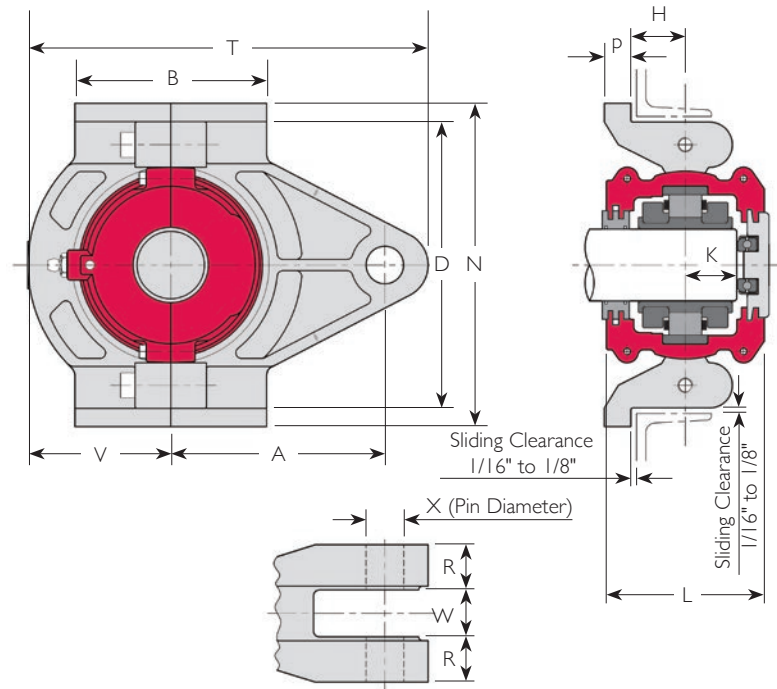

Shaft Diameter d (in)	References		B (in)	N (in)	D (in)	A (in)	T (in)	X (in)	V (in)	K (in)	P (in)	H (in)	W (in)	R (in)	L (in)	Mass (Complete Unit) (lb)
	Complete Unit (I)	Take-Up Housing Only														
2 1/4	01E BCTT 204 AT	TT03	5	9 1/4	8	5 3/4	11	15/16	4	1 3/16	13/16	1 1/4	1 3/16	1 1/8	4 1/8	28.6
	02 BCTT 204 AT	TT04	6	10 1/2	9	6 1/4	12	15/16	4 1/2	1 1/2	7/8	1 9/16	1 3/16	1 1/4	4 15/16	41.8
2 7/16	01E BCTT 207 AT	TT03	5	9 1/4	8	5 3/4	11	15/16	4	1 3/16	13/16	1 1/4	1 3/16	1 1/8	4 1/8	28.6
	02 BCTT 207 AT	TT04	6	10 1/2	9	6 1/4	12	15/16	4 1/2	1 1/2	7/8	1 9/16	1 3/16	1 1/4	4 15/16	41.8
2 1/2	01E BCTT 208 AT	TT03	5	9 1/4	8	5 3/4	11	15/16	4	1 3/16	13/16	1 1/4	1 3/16	1 1/8	4 1/8	28.6
	02 BCTT 208 AT	TT04	6	10 1/2	9	6 1/4	12	15/16	4 1/2	1 1/2	7/8	1 9/16	1 3/16	1 1/4	4 15/16	41.8
2 11/16	01E BCTT 211 AT	TT04	6	10 1/2	9	6 1/4	12	15/16	4 1/2	1 3/8	7/8	1 9/16	1 3/16	1 1/4	4 1/2	41.8
	02 BCTT 211 AT	TT05	7 1/2	12 1/2	11	7 1/2	14 1/2	1 3/16	5 1/2	1 5/8	7/8	1 9/16	1 1/2	1 3/8	5 1/2	66.0
2 3/4	01E BCTT 212 AT	TT04	6	10 1/2	9	6 1/4	12	15/16	4 1/2	1 3/8	7/8	1 9/16	1 3/16	1 1/4	4 1/2	41.8
	02 BCTT 212 AT	TT05	7 1/2	12 1/2	11	7 1/2	14 1/2	1 3/16	5 1/2	1 5/8	7/8	1 9/16	1 1/2	1 3/8	5 1/2	66.0
2 15/16	100 BCTT 215 AT	TT03	5	9 1/4	8	5 3/4	11	15/16	4	1 3/16	13/16	1/4	1 3/16	1 1/8	4 1/8	28.6
	01E BCTT 215 AT	TT04	6	10 1/2	9	6 1/4	12	15/16	4 1/2	1 3/8	7/8	1 9/16	1 3/16	1 1/4	4 1/2	41.8
	02 BCTT 215 AT	TT05	7 1/2	12 1/2	11	7 1/2	14 1/2	1 3/16	5 1/2	1 5/8	7/8	1 9/16	1 1/2	1 3/8	5 1/2	66.0

Inch-Size Take-Up Tension Type Units From 3" To 4 3/16" Bore Size

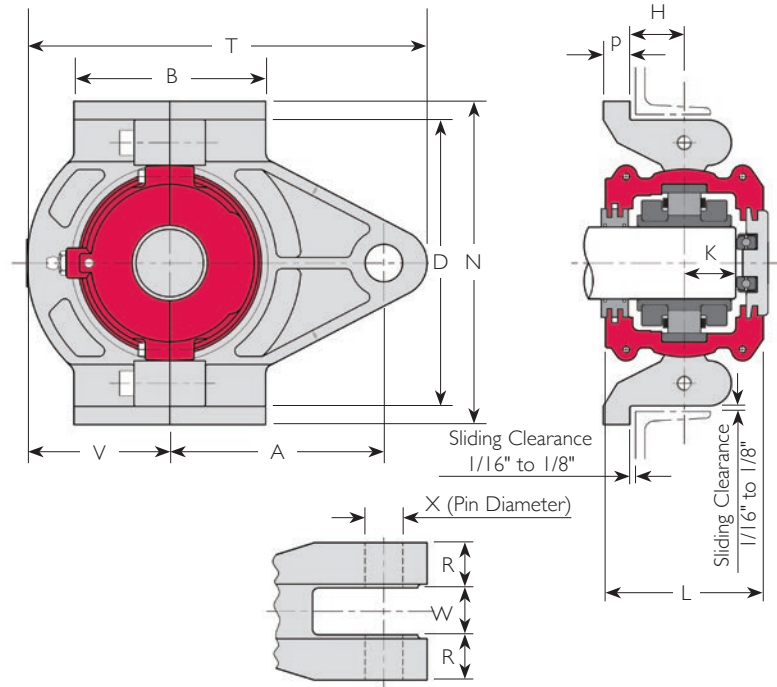

Shaft Diameter d (in)	References		B (in)	N (in)	D (in)	A (in)	T (in)	X (in)	V (in)	K (in)	P (in)	H (in)	W (in)	R (in)	L (in)	Mass (Complete Unit) (lb)
	Complete Unit (1)	Take-Up Housing Only														
3	100 BCTT 300 AT	TT03	5	9 1/4	8	5 3/4	11	15/16	4	1 3/16	13/16	1 1/4	1 3/16	1 1/8	4 1/8	28.6
	01E BCTT 300 AT	TT04	6	10 1/2	9	6 1/4	12	15/16	4 1/2	1 3/8	7/8	1 9/16	1 3/16	1 1/4	4 1/2	41.8
	02 BCTT 300 AT	TT05	7 1/2	12 1/2	11	7 1/2	14 1/2	1 3/16	5 1/2	1 5/8	7/8	1 9/16	1 1/2	1 3/8	5 1/2	66.0
3 3/16	01E BCTT 303 AT	TT05	7 1/2	12 1/2	11	7 1/2	14 1/2	1 3/16	5 1/2	1 9/16	7/8	1 9/16	1 1/2	1 3/8	5 3/8	66.0
	02 BCTT 303 AT	TT06	8	13 1/2	12	8 1/4	16 1/4	1 7/16	6	1 7/8	7/8	1 11/16	1 3/4	1 3/8	6 1/16	74.8
3 1/4	01E BCTT 304 AT	TT05	7 1/2	12 1/2	11	7 1/2	14 1/2	1 3/16	5 1/2	1 9/16	7/8	1 9/16	1 1/2	1 3/8	5 3/8	66.0
	02 BCTT 304 AT	TT06	8	13 1/2	12	8 1/4	16 1/4	1 7/16	6	1 7/8	7/8	1 11/16	1 3/4	1 3/8	6 1/16	74.8
3 7/16	100 BCTT 307 AT	TT04	6	10 1/2	9	6 1/4	12	15/16	4 1/2	1 3/8	7/8	1 9/16	1 3/16	1 1/4	4 1/2	41.8
	01E BCTT 307 AT	TT05	7 1/2	12 1/2	11	7 1/2	14 1/2	1 3/16	5 1/2	1 9/16	7/8	1 9/16	1 1/2	1 3/8	5 3/8	66.0
	02 BCTT 307 AT	TT06	8	13 1/2	12	8 1/4	16 1/4	1 7/16	6	1 7/8	7/8	1 11/16	1 3/4	1 3/8	6 1/16	74.8
3 1/2	01E BCTT 308 AT	TT05	7 1/2	12 1/2	11	7 1/2	14 1/2	1 3/16	5 1/2	1 9/16	7/8	1 9/16	1 1/2	1 3/8	5 3/8	66.0
	02 BCTT 308 AT	TT06	8	13 1/2	12	8 1/4	16 1/4	1 7/16	6	1 7/8	7/8	1 11/16	1 3/4	1 3/8	6 1/16	74.8

1) For radial bearing only reference (for standard arrangement) remove 'CTT' and 'AT' from complete unit reference and add 'EX', e.g. 01E B 307 EX

Ball thrust bearings are usually supplied complete with blanking plate. Refer to page 28

For cartridge reference refer to pages 38 to 42

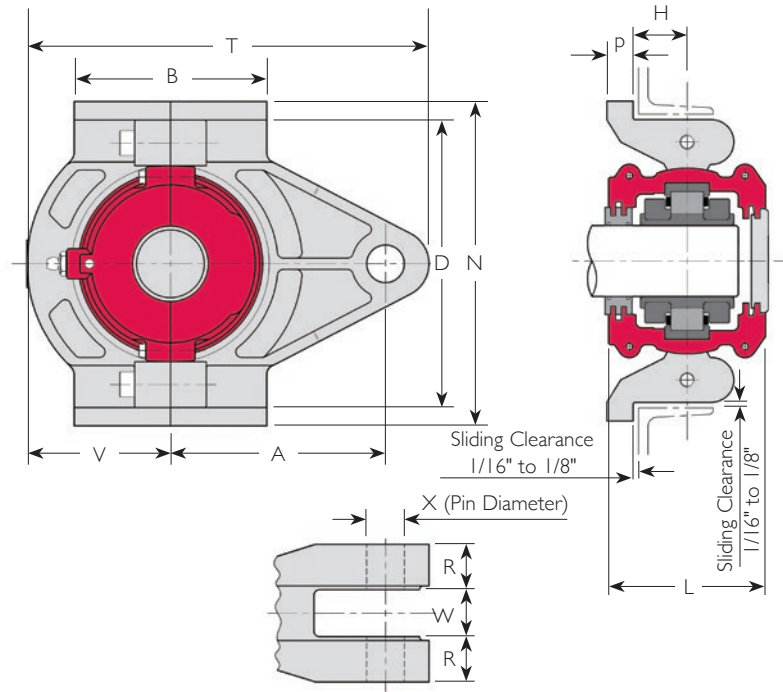

Shaft Diameter d (in)	References		B (in)	N (in)	D (in)	A (in)	T (in)	X (in)	V (in)	P (in)	H (in)	W (in)	R (in)	L (in)	Mass (Complete Unit) (lb)
	Complete Unit (I)	Take-Up Housing Only													
3 11/16	01E BCTT 311 AT	TT06	8	13 1/2	12	8 1/4	16 1/4	1 7/16	6	7/8	1 11/16	1 3/4	1 3/8	5 1/4	74.8
	02 BCTT 311 AT	TT07	8 1/2	15	13 1/2	9	17 1/2	1 5/8	6 3/8	7/8	1 7/8	1 3/4	1 5/8	5 3/4	112
3 3/4	01E BCTT 312 AT	TT06	8	13 1/2	12	8 1/4	16 1/4	1 7/16	6	7/8	1 11/16	1 3/4	1 3/8	5 1/4	74.8
	02 BCTT 312 AT	TT07	8 1/2	15	13 1/2	9	17 1/2	1 5/8	6 3/8	7/8	1 7/8	1 3/4	1 5/8	5 3/4	112
3 15/16	100 BCTT 315 AT	TT05	7 1/2	12 1/2	11	7 1/2	14 1/2	1 3/16	5 1/2	7/8	1 9/16	1 1/2	1 3/4	5 3/8	63.8
	01E BCTT 315 AT	TT06	8	13 1/2	12	8 1/4	16 1/4	1 7/16	6	7/8	1 11/16	1 3/4	1 3/8	5 1/4	74.8
	02 BCTT 315 AT	TT07	8 1/2	15	13 1/2	9	17 1/2	1 5/8	6 3/8	7/8	1 7/8	1 3/4	1 5/8	5 3/4	112
4	100 BCTT 400 AT	TT05	7 1/2	12 1/2	11	7 1/2	14 1/2	1 3/16	5 1/2	7/8	1 9/16	1 1/2	1 3/4	5 3/8	63.8
	01E BCTT 400 AT	TT06	8	13 1/2	12	8 1/4	16 1/4	1 7/16	6	7/8	1 11/16	1 3/4	1 3/8	5 1/4	74.8
	02 BCTT 400 AT	TT07	8 1/2	15	13 1/2	9	17 1/2	1 5/8	6 3/8	7/8	1 7/8	1 3/4	1 5/8	5 3/4	112
4 3/16	01 BCTT 403 AT	TT07	8 1/2	15	13 1/2	9	17 1/2	1 5/8	6 3/8	7/8	1 7/8	1 3/4	1 5/8	5 9/16	112
	02 BCTT 403 AT	TT08	10	16 1/2	15	10 1/4	20	1 5/8	7 1/2	1	2	1 3/4	1 3/4	6 3/8	156

Inch-Size Take-Up Tension Type Units From 4 7/16" To 6" Bore Size

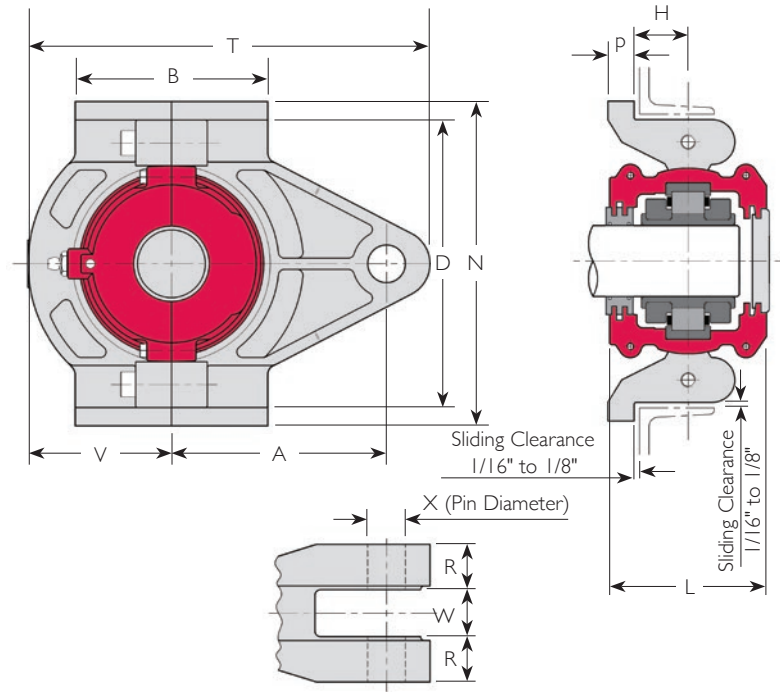

Shaft Diameter d (in)	References		B (in)	N (in)	D (in)	A (in)	T (in)	X (in)	V (in)	P (in)	H (in)	W (in)	R (in)	L (in)	Mass (Complete Unit) (lb)
	Complete Unit (1)	Take-Up Housing Only													
4 7/16	100 BCTT 407 AT	TT06	8	13 1/2	12	8 1/4	16 1/4	1 7/16	6	7/8	1 11/16	1 3/4	1 3/8	5 1/4	72.6
	01 BCTT 407 AT	TT07	8 1/2	15	13 1/2	9	17 1/2	1 5/8	6 3/8	7/8	1 7/8	1 3/4	1 5/8	5 9/16	112
	02 BCTT 407 AT	TT08	10	16 1/2	15	10 1/4	20	1 5/8	7 1/2	1	2	1 3/4	1 15/16	6 3/8	156
4 1/2	100 BCTT 408 AT	TT06	8	13 1/2	12	8 1/4	16 1/4	1 7/16	6	7/8	1 11/16	1 3/4	1 3/8	5 1/4	72.6
	01 BCTT 408 AT	TT07	8 1/2	15	13 1/2	9	17 1/2	1 5/8	6 3/8	7/8	1 7/8	1 3/4	1 5/8	5 9/16	112
	02 BCTT 408 AT	TT08	10	16 1/2	15	10 1/4	20	1 5/8	7 1/2	1	2	1 3/4	1 15/16	6 3/8	156
4 15/16	100 BCTT 415 AT	TT07	8 1/2	15	13 1/2	9	17 1/2	1 5/8	6 3/8	7/8	1 7/8	1 3/4	1 5/8	5 9/16	103
	01 BCTT 415 AT	TT08	10	16 1/2	15	10 1/4	20	1 5/8	7 1/2	1	2	1 3/4	1 15/16	6 1/8	156
	02 BCTT 415 AT	TT10	10 1/2	18 1/4	16 3/4	11	21 1/2	1 7/16	8	1	2 1/4	1 15/16	2	7 1/4	220
5	100 BCTT 500 AT	TT07	8 1/2	15	13 1/2	9	17 1/2	1 5/8	6 3/8	7/8	1 7/8	1 3/4	1 5/8	5 9/16	103
	01 BCTT 500 AT	TT08	10	16 1/2	15	10 1/4	20	1 5/8	7 1/2	1	2	1 3/4	1 15/16	6 1/8	156
	02 BCTT 500 AT	TT10	10 1/2	18 1/4	16 3/4	11	21 1/2	1 7/16	8	1	2 1/4	1 15/16	2	7 1/4	220
5 3/16	01 BCTT 503 AT	TT09	10 1/2	17 1/4	15 3/4	10 1/2	20 1/4	1 5/8	7 11/16	1	2 1/8	1 3/4	1 7/8	6 5/8	196
	02 BCTT 503 AT	TT30	11	19 3/4	18 1/4	11 3/4	23	1 7/8	8 3/4	1	2 3/8	1 15/16	2 1/8	7 3/8	262

1) For radial bearing only reference (for standard arrangement) remove 'CTT' and 'AT' from complete unit reference and add 'EX', e.g. 01 B 407 EX

Ball thrust bearings are usually supplied complete with blanking plate. Refer to page 28

For cartridge reference refer to pages 42 to 44

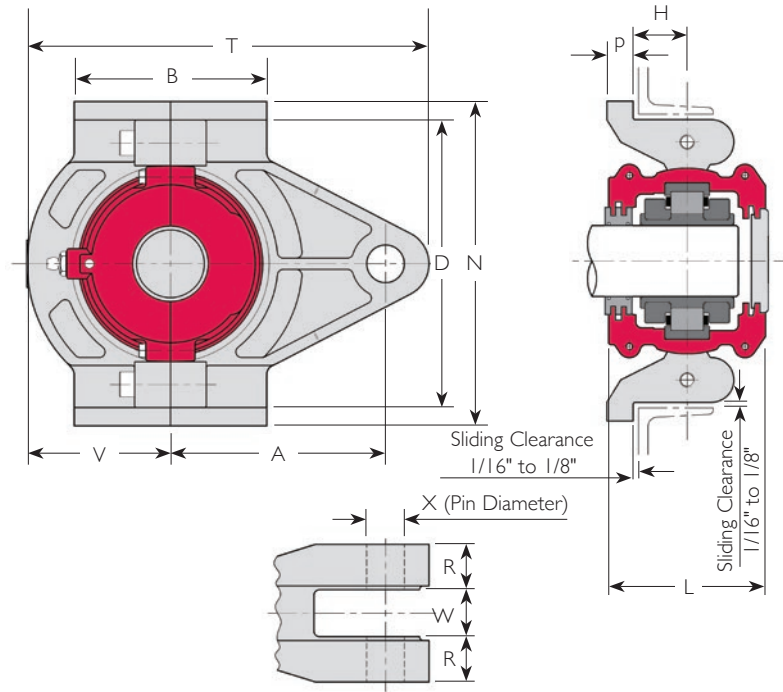

Shaft Diameter d (in)	References		B (in)	N (in)	D (in)	A (in)	T (in)	X (in)	V (in)	P (in)	H (in)	W (in)	R (in)	L (in)	Mass (Complete Unit) (lb)
	Complete Unit (I)	Take-Up Housing Only													
5 7/16	100 BCTT 507 AT	TT08	10	16 1/2	15	10 1/4	20	1 5/8	7 1/2	1	2	1 3/4	1 3/4	6 1/8	147
	01 BCTT 507 AT	TT09	10 1/2	17 1/4	15 3/4	10 1/2	20 1/4	1 5/8	7 11/16	1	2 1/8	1 3/4	1 7/8	6 5/8	196
	02 BCTT 507 AT	TT30	11	19 3/4	18 1/4	11 3/4	23	1 7/8	8 3/4	1	2 3/8	1 15/16	2 1/8	7 3/8	262
5 1/2	100 BCTT 508 AT	TT08	10	16 1/2	15	10 1/4	20	1 5/8	7 1/2	1	2	1 3/4	1 3/4	6 1/8	147
	01 BCTT 508 AT	TT09	10 1/2	17 1/4	15 3/4	10 1/2	20 1/4	1 5/8	7 11/16	1	2 1/8	1 3/4	1 7/8	6 5/8	196
	02 BCTT 508 AT	TT30	11	19 3/4	18 1/4	11 3/4	23	1 7/8	8 3/4	1	2 1/8	1 15/16	2 1/8	7 3/8	262
5 15/16	100 BCTT 515 AT	TT09	10 1/2	17 1/4	15 3/4	10 1/2	20 1/4	1 5/8	7 11/16	1	2 1/8	1 3/4	1 7/8	6 5/8	180
	01 BCTT 515 AT	TT10	10 1/2	18 1/4	16 3/4	11	21 1/2	1 7/8	8	1	2 1/4	1 15/16	2	6 7/8	220
	02 BCTT 515 AT	TT31	12	20 3/4	19 1/4	12 1/4	24 1/4	1 7/8	9 1/4	1	2 1/2	1 15/16	2 1/4	8	310
6	100 BCTT 600 AT	TT09	10 1/2	17 1/4	15 3/4	10 1/2	20 1/4	1 5/8	7 11/16	1	2 1/8	1 3/4	1 7/8	6 5/8	180
	01 BCTT 600 AT	TT10	10 1/2	18 1/4	16 3/4	11	21 1/2	1 7/8	8	1	2 1/4	1 15/16	2	6 7/8	220
	02 BCTT 600 AT	TT31	12	20 3/4	19 1/4	12 1/4	24 1/4	1 7/8	9 1/4	1	2 1/2	1 15/16	2 1/4	8	310

Metric Take-Up Push Type Units From 40mm To 90mm Bore Size

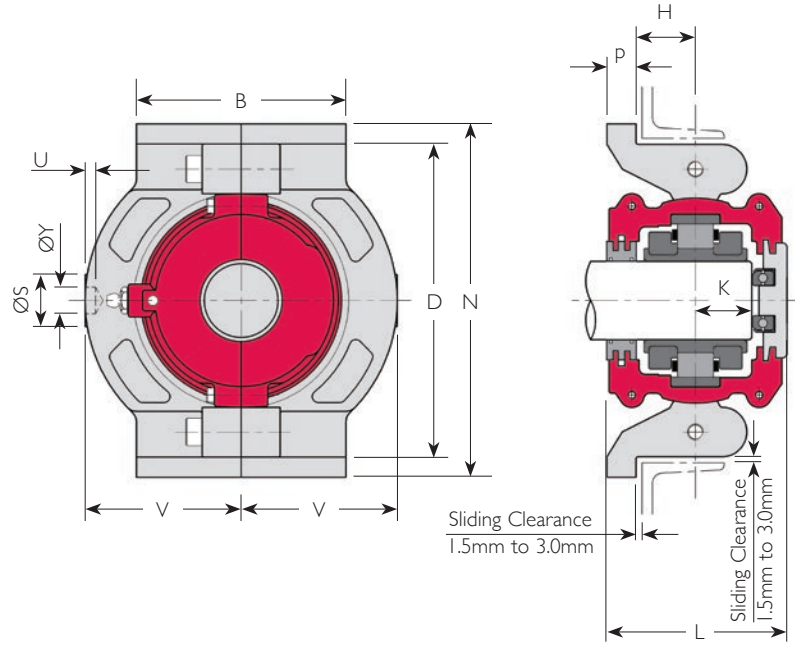

Shaft Diameter d (mm)	References		B (mm)	N (mm)	D (mm)	V (mm)	K (mm)	P (mm)	H (mm)	L (mm)	S (mm)	Y (mm)	U (mm)	Mass (Complete Unit) (kg)
	Complete Unit (I)	Take-Up Housing Only												
40	01 BCTP 40M AT	TP01	102	172	153	76	27	14	29	86	25	13	5	6
45	01E BCTP 45M AT	TP02	114	204	178	88	29	16	29	98	29	13	5	9
50	01E BCTP 50M AT	TP02	114	204	178	88	29	16	29	98	29	13	5	9
	02 BCTP 50M AT	TP03	128	235	203	102	35	20	32	114	38	16	6	12
60	01E BCTP 60M AT	TP03	128	235	203	102	30	20	32	104	38	16	6	13
	02 BCTP 60M AT	TP04	152	266	229	114	38	22	40	126	41	16	6	17
65	01E BCTP 65M AT	TP03	128	235	203	102	30	20	32	104	38	16	6	13
	02 BCTP 65M AT	TP04	152	266	229	114	38	22	40	126	41	16	6	17
70	01E BCTP 70M AT	TP04	152	266	229	114	35	22	40	114	41	16	6	17
	02 BCTP 70M AT	TP05	190	318	280	140	41	22	40	140	51	16	6	27
75	100 BCTP 75M AT	TP03	128	235	203	102	30	20	32	104	38	16	6	13
	01E BCTP 75M AT	TP04	152	266	229	114	35	22	40	114	41	16	6	17
	02 BCTP 75M AT	TP05	190	318	280	140	41	22	40	140	51	16	6	27

1) For radial bearing only reference (for standard arrangement) remove 'CTP' and 'AT' from complete unit reference and add 'EX', e.g. 01E B 60M EX

Ball thrust bearings are usually supplied complete with blanking plate. Refer to page 28

For cartridge reference refer to pages 54 to 56

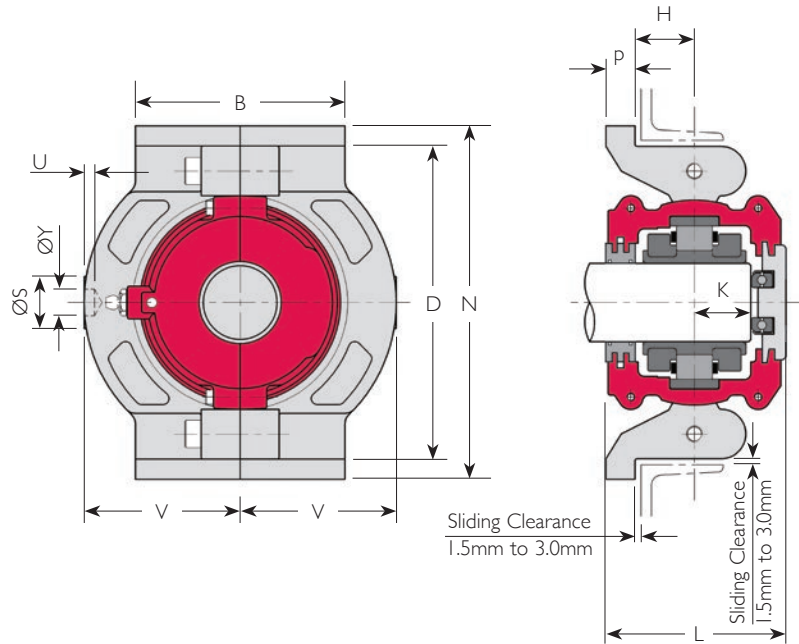

Shaft Diameter d (mm)	References		B (mm)	N (mm)	D (mm)	V (mm)	K (mm)	P (mm)	H (mm)	L (mm)	S (mm)	Y (mm)	U (mm)	Mass (Complete Unit) (kg)
	Complete Unit (I)	Take-Up Housing Only												
80	01E BCTP 80M AT	TP05	190	318	280	140	40	22	40	136	51	16	6	27
	02 BCTP 80M AT	TP06	204	342	305	152	48	22	43	154	51	19	6	31
85	100 BCTP 85M AT	TP04	152	266	229	114	35	22	40	114	41	16	6	17
	01E BCTP 85M AT	TP05	190	318	280	140	40	22	40	136	51	16	6	27
	02 BCTP 85M AT	TP06	204	342	305	152	48	22	43	154	51	19	6	31
90	01E BCTP 90M AT	TP05	190	318	280	140	40	22	40	136	51	16	6	27
	02 BCTP 90M AT	TP06	204	342	305	152	48	22	43	154	51	19	6	31

Metric Take-Up Push Type Units From 100mm To 155mm Bore Size

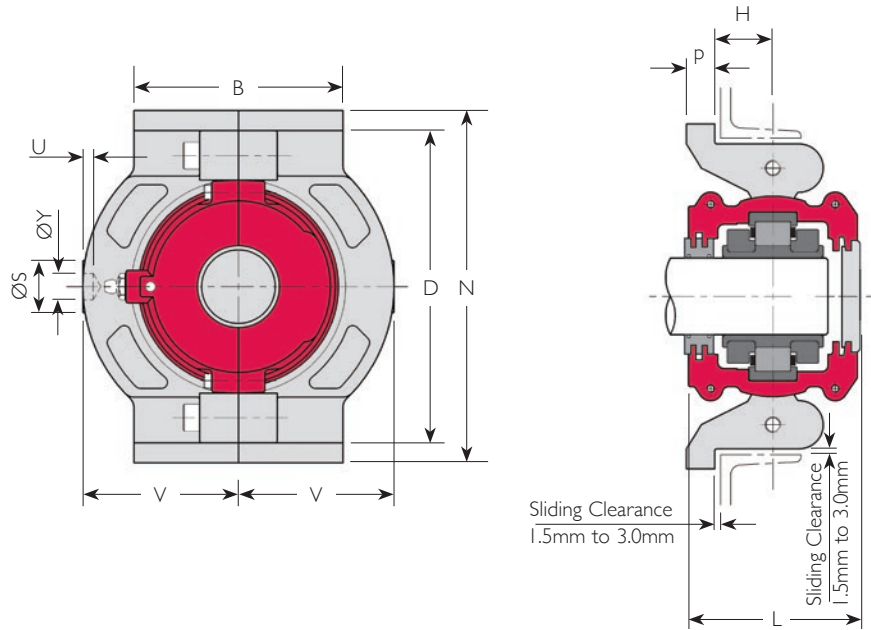

Shaft Diameter d (mm)	References		B (mm)	N (mm)	D (mm)	V (mm)	P (mm)	H (mm)	L (mm)	S (mm)	Y (mm)	U (mm)	Mass (Complete Unit) (kg)
	Complete Unit (I)	Take-Up Housing Only											
100	100 BCTP 100M AT	TP05	190	318	280	140	22	40	136	51	16	6	26
	01E BCTP 100M AT	TP06	204	342	305	152	22	43	134	51	19	6	31
	02 BCTP 100M AT	TP07	216	382	343	162	22	48	146	70	19	6	46
105	01E BCTP 105M AT	TP06	204	342	305	152	22	43	134	51	19	6	31
	02 BCTP 105M AT	TP07	216	382	343	162	22	48	146	70	19	6	46
110	100 BCTP 110M AT	TP06	204	342	305	152	22	43	134	51	19	6	29
	01 BCTP 110M AT	TP07	216	382	343	162	22	48	142	70	19	6	46
	02 BCTP 110M AT	TP08	254	420	381	190	25	51	162	76	19	6	65
115	01 BCTP 115M AT	TP07	216	382	343	162	22	48	142	70	19	6	46
	02 BCTP 115M AT	TP08	254	420	381	190	25	51	162	76	19	6	65
120	100 BCTP 120M AT	TP07	216	382	343	162	22	48	142	70	19	6	42
	01 BCTP 120M AT	TP08	254	420	381	190	25	51	156	76	19	6	65
	02 BCTP 120M AT	TP10	266	464	426	204	25	57	184	86	23	8	91
125	01 BCTP 125M AT	TP08	254	420	381	190	25	51	156	76	19	6	65
	02 BCTP 125M AT	TP10	266	464	426	204	25	57	184	86	23	8	91

I) For radial bearing only reference (for standard arrangement) remove 'CTP' and 'AT' from complete unit reference and add 'GR', e.g. 01 B 110M GR
 For cartridge reference refer to pages 56 to 60

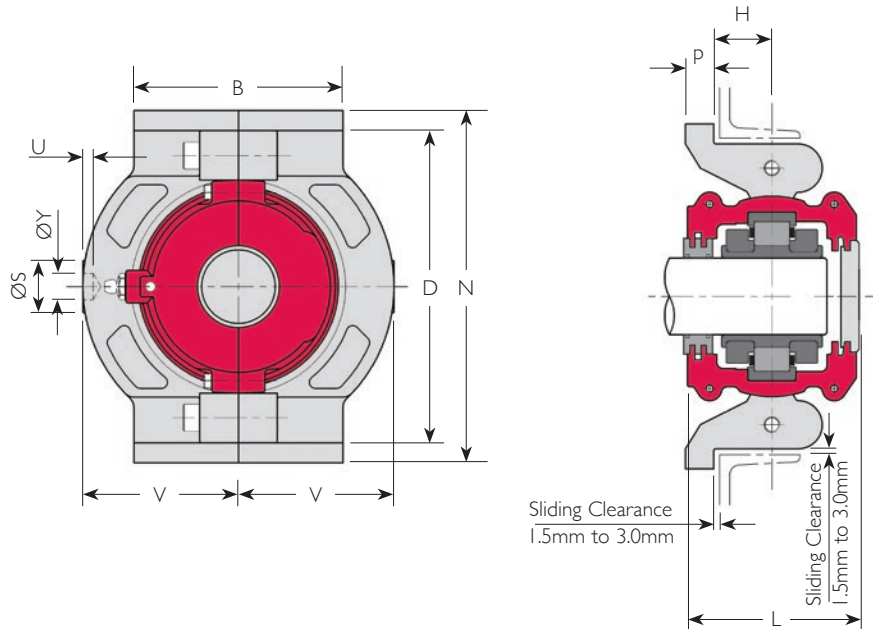

Shaft Diameter d (mm)	References		B (mm)	N (mm)	D (mm)	V (mm)	P (mm)	H (mm)	L (mm)	S (mm)	Y (mm)	U (mm)	Mass (Complete Unit) (kg)
	Complete Unit (I)	Take-Up Housing Only											
130	100 BCTP 130M AT	TP07	216	382	343	162	22	48	142	70	19	6	42
	01 BCTP 130M AT	TP08	254	420	381	190	25	51	156	76	19	6	65
	02 BCTP 130M AT	TP10	266	464	426	204	25	57	184	86	23	8	91
135	01 BCTP 135M AT	TP09	266	438	400	196	25	54	168	76	23	8	80
	02 BCTP 135M AT	TP30	280	502	464	222	25	60	188	92	23	8	109
140	100 BCTP 140M AT	TP08	254	420	381	190	25	51	156	76	19	6	60
	01 BCTP 140M AT	TP09	266	438	400	196	25	54	168	76	23	8	80
	02 BCTP 140M AT	TP30	280	502	464	222	25	60	188	92	23	8	109
150	100 BCTP 150M AT	TP09	266	438	400	196	25	54	168	76	23	8	73
	01 BCTP 150M AT	TP10	266	464	426	204	25	57	174	86	23	8	91
	02 BCTP 150M AT	TP31	305	528	489	235	25	64	204	92	26	10	109
155	01 BCTP 155M AT	TP10	266	464	426	204	25	57	174	86	23	8	91
	02 BCTP 155M AT	TP31	305	528	489	235	25	64	204	92	26	10	109

Metric Take-Up Push Type Units From 40mm To 90mm Bore Size

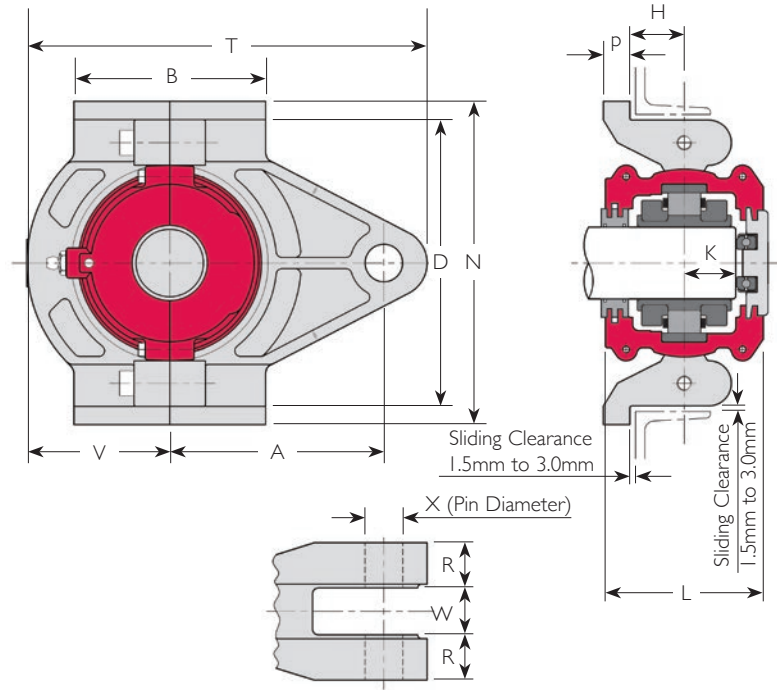

Shaft Diameter d (mm)	References		B (mm)	N (mm)	D (mm)	A (mm)	T (mm)	X (mm)	V (mm)	K (mm)	P (mm)	H (mm)	W (mm)	R (mm)	L (mm)	Mass (Complete Unit) (kg)
	Complete Unit (I)	Take-Up Housing Only														
40	01 BCTT 40M AT	TT01	102	172	153	114	216	20	76	27	14	29	25	24	86	7
45	01E BCTT 45M AT	TT02	114	204	178	128	242	24	88	29	16	29	25	25	98	10
50	01E BCTT 50M AT	TT02	114	204	178	128	242	24	88	29	16	29	25	25	98	10
	02 BCTT 50M AT	TT03	128	235	203	146	280	24	102	35	20	32	30	29	114	13
60	01E BCTT 60M AT	TT03	128	235	203	146	280	24	102	35	20	32	30	29	104	13
	02 BCTT 60M AT	TT04	152	266	229	158	305	24	114	38	22	40	30	32	126	19
65	01E BCTT 65M AT	TT03	128	235	203	146	280	24	102	35	20	32	30	29	104	13
	02 BCTT 65M AT	TT04	152	266	229	158	305	24	114	38	22	40	30	32	126	19
70	01E BCTT 70M AT	TT04	152	266	229	158	305	24	114	35	22	40	30	32	114	19
	02 BCTT 70M AT	TT05	190	318	280	190	368	30	140	41	22	40	38	35	140	30

1) For radial bearing only reference (for standard arrangement) remove 'CTT' and 'AT' from complete unit reference and add 'EX', e.g. 01E B 60M EX

Ball thrust bearings are usually supplied complete with blanking plate. Refer to page 28

For cartridge reference refer to pages 54 to 56

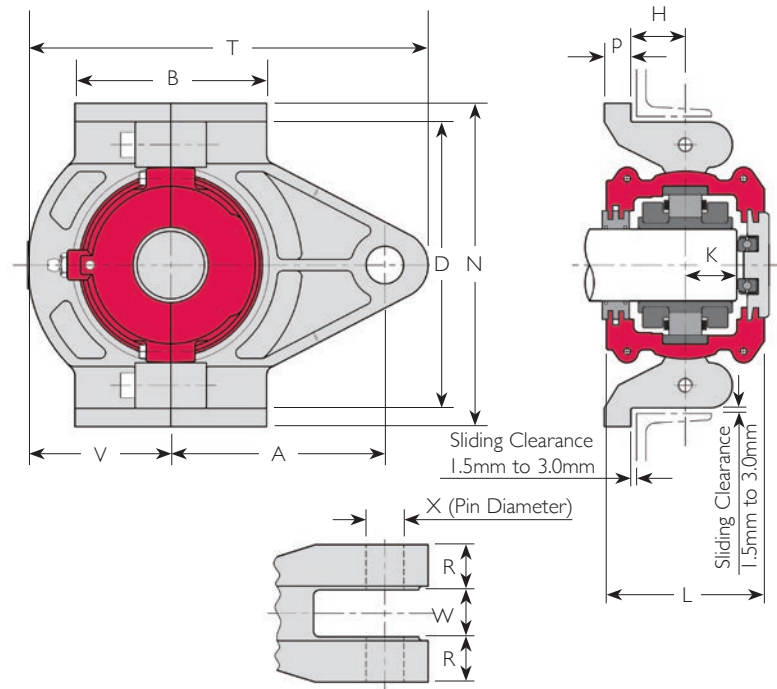

Shaft Diameter d (mm)	References		B (mm)	N (mm)	D (mm)	A (mm)	T (mm)	X (mm)	V (mm)	K (mm)	P (mm)	H (mm)	W (mm)	R (mm)	L (mm)	Mass (Complete Unit) (kg)
	Complete Unit (I)	Take-Up Housing Only														
75	100 BCTT 75M AT	TT03	128	235	203	146	280	24	102	30	20	32	30	29	104	13
	01E BCTT 75M AT	TT04	152	266	229	158	305	24	114	35	22	40	30	32	114	19
	02 BCTT 75M AT	TT05	190	318	280	190	368	30	140	41	22	40	38	35	140	30
80	01E BCTT 80M AT	TT05	190	318	280	190	368	30	140	40	22	40	38	35	136	30
	02 BCTT 80M AT	TT06	204	342	305	210	414	36	152	48	22	43	44	35	154	34
85	100 BCTT 85M AT	TT04	152	266	229	158	305	24	114	35	22	40	30	32	114	19
	01E BCTT 85M AT	TT05	190	318	280	190	368	30	140	40	22	40	38	35	136	30
	02 BCTT 85M AT	TT06	204	342	305	210	414	36	152	48	22	43	44	35	154	34
90	01E BCTT 90M AT	TT05	190	318	280	190	368	30	140	40	22	40	38	35	136	30
	02 BCTT 90M AT	TT06	204	342	305	210	414	36	152	48	22	43	44	35	154	34

Metric Take-Up Tension Type Units From 100mm To 155mm Bore Size

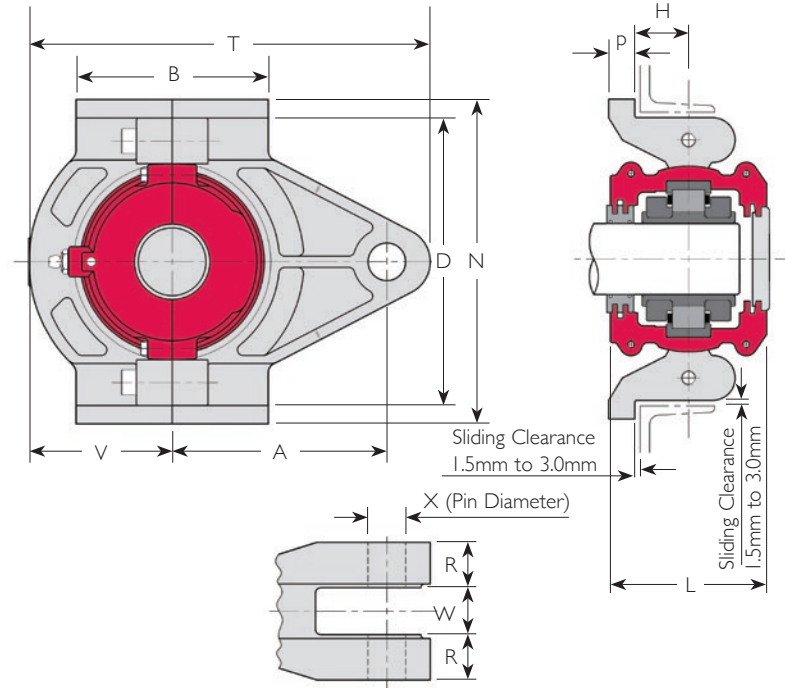

Shaft Diameter d (mm)	References		B (mm)	N (mm)	D (mm)	A (mm)	T (mm)	X (mm)	V (mm)	P (mm)	H (mm)	W (mm)	R (mm)	L (mm)	Mass (Complete Unit) (kg)
	Complete Unit (I)	Take-Up Housing Only													
100	100 BCTT 100M AT	TT05	190	318	280	190	368	30	140	22	40	38	35	136	29
	01E BCTT 100M AT	TT06	204	342	305	210	414	36	152	22	43	44	35	134	34
	02 BCTT 100M AT	TT07	216	382	343	228	445	42	162	22	48	44	41	146	51
105	01E BCTT 105M AT	TT06	204	342	305	210	414	36	152	22	43	44	35	134	34
	02 BCTT 105M AT	TT07	216	382	343	228	445	42	162	22	48	44	41	146	51
110	100 BCTT 110M AT	TT06	204	342	305	210	414	36	152	22	43	44	35	134	33
	01 BCTT 110M AT	TT07	216	382	343	228	445	42	162	22	48	44	41	142	51
	02 BCTT 110M AT	TT08	254	420	381	260	508	42	190	25	51	44	44	162	71
115	01 BCTT 115M AT	TT07	216	382	343	228	445	42	162	22	48	44	41	142	51
	02 BCTT 115M AT	TT08	254	420	381	260	508	42	190	25	51	44	44	162	71
120	100 BCTT 120M AT	TT07	216	382	343	228	445	42	162	22	48	44	41	142	47
	01 BCTT 120M AT	TT08	254	420	381	260	508	42	190	25	51	44	44	156	71
	02 BCTT 120M AT	TT10	266	464	426	280	546	48	204	25	57	50	51	184	100
125	01 BCTT 125M AT	TT08	254	420	381	260	508	42	190	25	51	44	44	156	71
	02 BCTT 125M AT	TT10	266	464	426	280	546	48	204	25	57	50	51	184	100

1) For radial bearing only reference (for standard arrangement) remove 'CTT' and 'AT' from complete unit reference and add 'GR', e.g. 01 B 110M GR
 For cartridge reference refer to pages 56 to 60

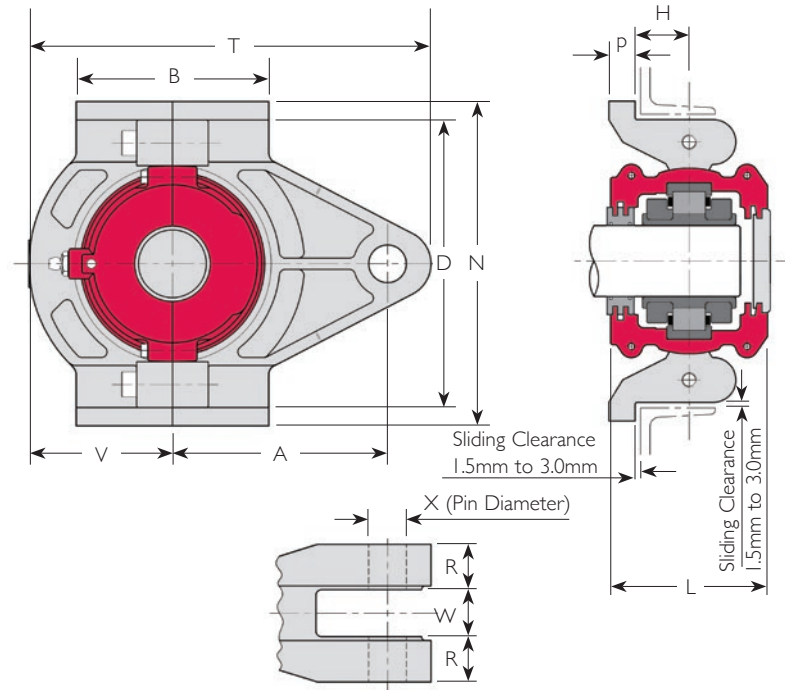

Shaft Diameter d (mm)	References		B (mm)	N (mm)	D (mm)	A (mm)	T (mm)	X (mm)	V (mm)	P (mm)	H (mm)	W (mm)	R (mm)	L (mm)	Mass (Complete Unit) (kg)
	Complete Unit (I)	Take-Up Housing Only													
130	100 BCTT 130M AT	TT07	216	382	343	228	445	42	162	22	48	44	41	142	47
	01 BCTT 130M AT	TT08	254	420	381	260	508	42	190	25	51	44	44	156	71
	02 BCTT 130M AT	TT10	266	464	426	280	546	48	204	25	57	50	51	184	100
135	01 BCTT 135M AT	TT09	266	438	400	266	514	42	196	25	54	44	48	168	89
	02 BCTT 135M AT	TT30	280	502	464	298	584	48	222	25	60	50	54	188	119
140	100 BCTT 140M AT	TT08	254	420	381	260	508	42	190	25	51	44	44	156	67
	01 BCTT 140M AT	TT09	266	438	400	266	514	42	196	25	54	44	48	168	89
	02 BCTT 140M AT	TT30	280	502	464	298	584	48	222	25	60	50	54	188	119
150	100 BCTT 150M AT	TT09	266	438	400	266	514	42	196	25	54	44	48	168	82
	01 BCTT 150M AT	TT10	266	464	426	280	546	48	204	25	57	50	51	174	100
	02 BCTT 150M AT	TT31	305	528	489	312	616	48	235	25	64	50	57	204	141
155	01 BCTT 155M AT	TT10	266	464	426	280	546	48	204	25	57	50	51	174	100
	02 BCTT 155M AT	TT31	305	528	489	312	616	48	235	25	64	50	57	204	141

Cooper split roller bearings in rod end housings provide a simple way of mounting roller bearings on cranks. As the complete bearing and housing unit is split radially, cranks can be made solid rather than being built-up or overhung. Typical applications include shaker screens and classifiers.

Rod ends are available to suit 100, 01/01E and 02 Series bearings as shown on pages 36 to 44 and 54 to 60.

Each rod end consists of a split outer casing, which encloses a fixed (GR) bearing in a swivel cartridge (refer to page 31). Two basic configurations are available – the 'T' type and the 'shoe' type. These can be modified to suit various rods and attachments.

Standard rod ends are of gray iron. Spheroidal graphite iron or steel versions are available.

Rod ends are supplied with matched cartridge to reduce the clearance between the cartridge and rod-end (SI fit).

Except for very slow speed applications, bearings with C2 clearance should be specified.

Dimensions and load capacities of housings should be confirmed before finalizing designs.

SHAFT DIMENSIONS

Journals should be machined to h6 tolerance. Close tolerance machining to the sides of the journal is not required. These are clearance only (i.e. not locating) as the bearing is positioned by the inner race being clamped onto the shaft.

The journal widths and fillet radii listed in the tables are suggested dimensions to clear standard Cooper cartridges. Special cartridges may be supplied if narrower journals are required.

'T' TYPE

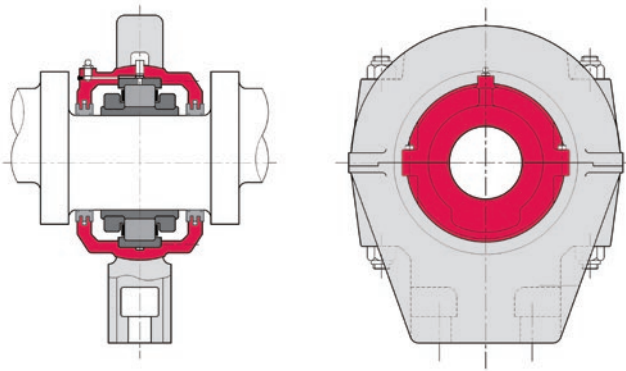

SHOE TYPE

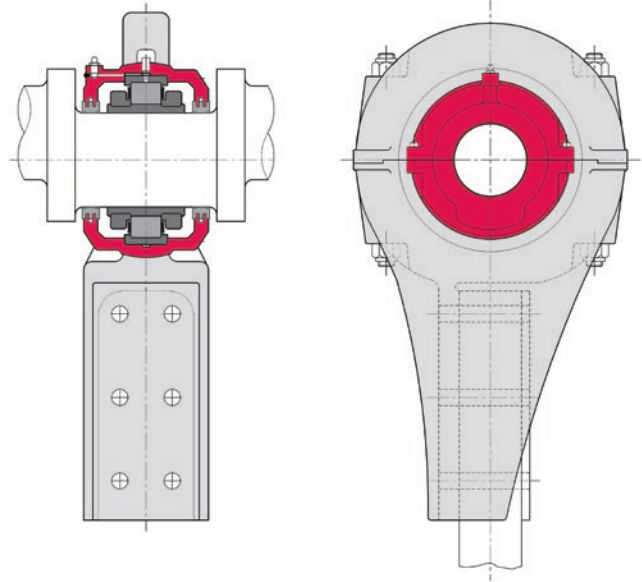

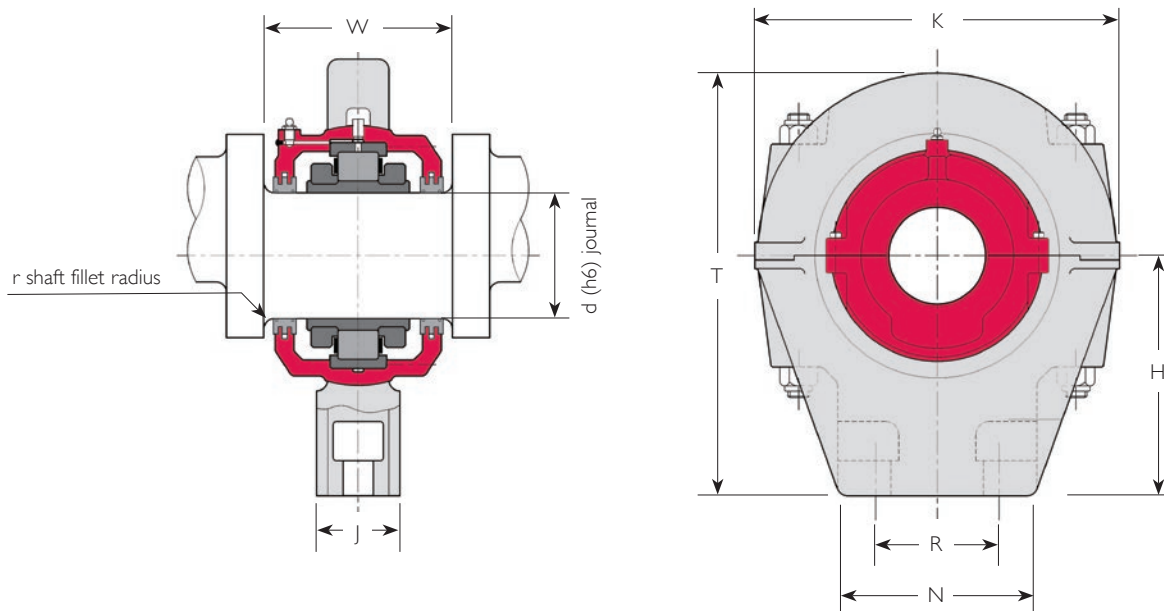

Shaft Diameter d (in)	Reference (1) (Complete Unit)	W (in)	r (max) (in)	N (in)	J (in)	H (in)	K (in)	T (in)	R (in)	Bolts		Mass (Complete Unit) (lb)
										Metric Size	Inch Size	
1 3/16	01 BCRET 103 AT	3 5/8	1/8	3 3/8	1 3/16	3	5 1/2	6	2 1/4 (2)	M12	-	13.2
1 1/4	01 BCRET 104 AT	3 5/8	1/8	3 3/8	1 3/16	3	5 1/2	6	2 1/4 (2)	M12	-	13.2
1 7/16	01 BCRET 107 AT	3 5/8	1/8	3 3/8	1 3/16	3	5 1/2	6	2 1/4 (2)	M12	-	13.2
1 1/2	01 BCRET 108 AT	3 5/8	1/8	3 3/8	1 3/16	3	5 1/2	6	2 1/4 (2)	M12	-	13.2
1 11/16	01E BCRET 111 AT	4 1/16	1/8	4	1 1/4	4	6 9/16	7 1/2	2 3/4	M10	3/8"	17.6
1 3/4	01E BCRET 112 AT	4 1/16	1/8	4	1 1/4	4	6 9/16	7 1/2	2 3/4	M10	3/8"	17.6
1 15/16	01E BCRET 115 AT	4 1/16	1/8	4	1 1/4	4	6 9/16	7 1/2	2 3/4	M10	3/8"	17.6
	02 BCRET 115 AT	4 7/8	3/16	4 1/2	1 1/2	3 3/4	7 3/4	7 5/8	3 (2)	M16	-	19.8
2	01E BCRET 200 AT	4 1/16	1/8	4	1 1/4	4	6 9/16	7 1/2	2 3/4	M10	3/8"	17.6
	02 BCRET 200 AT	4 7/8	3/16	4 1/2	1 1/2	3 3/4	7 3/4	7 5/8	3 (2)	M16	-	19.8
2 3/16	01E BCRET 203 AT	4 7/16	3/16	4 1/2	1 1/2	3 3/4	7 3/4	7 5/8	3 (2)	M16	-	19.8
	02 BCRET 203 AT	5 7/16	1/4	5	1 3/4	4 1/4	8 1/2	8 11/16	3 1/2 (2)	M16	-	28.6
2 1/4	01E BCRET 204 AT	4 7/16	3/16	4 1/2	1 1/2	3 3/4	7 3/4	7 5/8	3 (2)	M16	-	19.8
	02 BCRET 204 AT	5 7/16	1/4	5	1 3/4	4 1/4	8 1/2	8 11/16	3 1/2 (2)	M16	-	28.6

1) For (matched) rod end and cartridge only without roller bearing remove 'B' from reference, e.g. 01 CRET 107 AT
 For (standard rod-end specification) bearing only remove 'CRET' and 'AT' from reference and add 'GR C2', e.g. 01 B 107 GR C2

2) Holes tapped in end face

Inch-size Rod-end Bearing Units T Type From 2 7/16" To 4" Bore Size

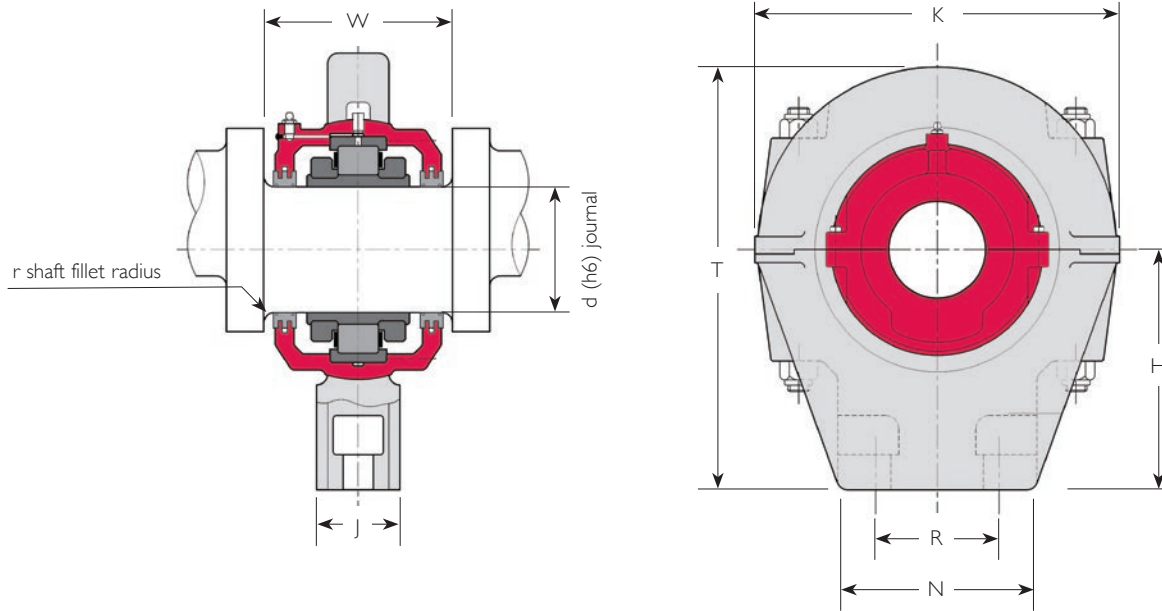

Shaft Diameter d (in)	Reference (1) (Complete Unit)	W (in)	r (max) (in)	N (in)	J (in)	H (in)	K (in)	T (in)	R (in)	Bolts		Mass (Complete Unit) (lb)
										Metric Size	Inch Size	
2 7/16	01E BCRET 207 AT	4 7/16	3/16	4 1/2	1 1/2	3 3/4	7 3/4	7 5/8	3 (2)	M16	-	19.8
	02 BCRET 207 AT	5 7/16	1/4	5	1 3/4	4 1/4	8 1/2	8 11/16	3 1/2 (2)	M16	-	28.6
2 1/2	01E BCRET 208 AT	4 7/16	3/16	4 1/2	1 1/2	3 3/4	7 3/4	7 5/8	3 (2)	M16	-	19.8
	02 BCRET 208 AT	5 7/16	1/4	5	1 3/4	4 1/4	8 1/2	8 11/16	3 1/2 (2)	M16	-	28.6
2 11/16	01E BCRET 211 AT	5	1/4	5	1 3/4	4 1/4	8 1/2	8 11/16	3 1/2 (2)	M16	-	28.6
	02 BCRET 211 AT	5 15/16	1/4	5 3/4	1 7/8	5	9 3/4	10 1/16	4 (2)	M20	-	44.0
2 3/4	01E BCRET 212 AT	5	1/4	5	1 3/4	4 1/4	8 1/2	8 11/16	3 1/2 (2)	M16	-	28.6
	02 BCRET 212 AT	5 15/16	1/4	5 3/4	1 7/8	5	9 3/4	10 1/16	4 (2)	M20	-	44.0
2 15/16	100 BCRET 215 AT	4 7/16	3/16	4 1/2	1 1/2	3 3/4	7 3/4	7 5/8	3 (2)	M16	-	19.8
	01E BCRET 215 AT	5	1/4	5	1 3/4	4 1/4	8 1/2	8 11/16	3 1/2 (2)	M16	-	28.6
	02 BCRET 211 AT	5 15/16	1/4	5 3/4	1 7/8	5	9 3/4	10 1/16	4 (2)	M20	-	44.0
3	100 BCRET 300 AT	4 7/16	3/16	4 1/2	1 1/2	3 3/4	7 3/4	7 5/8	3 (2)	M16	-	19.8
	01E BCRET 300 AT	5	1/4	5	1 3/4	4 1/4	8 1/2	8 11/16	3 1/2 (2)	M16	-	28.6
	02 BCRET 300 AT	5 15/16	1/4	5 3/4	1 7/8	5	9 3/4	10 1/16	4 (2)	M20	-	44.0

- 1) For (matched) rod end and cartridge only without roller bearing remove 'B' from reference, e.g. 01 CRET 307 AT
 For (standard rod-end specification) bearing only remove 'CRET' and 'AT' from reference and add 'GR C2', e.g. 01 B 307 GR C2

- 2) Holes tapped in end face

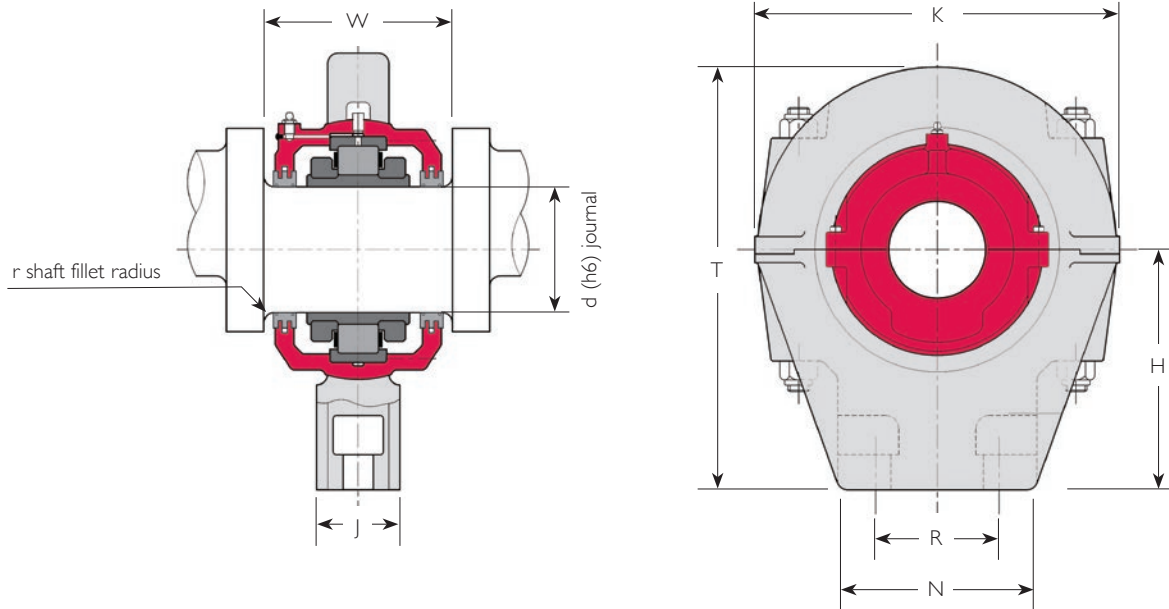

Shaft Diameter d (in)	Reference (I) (Complete Unit)	W (in)	r (max) (in)	N (in)	J (in)	H (in)	K (in)	T (in)	R (in)	Bolts		Mass (Complete Unit) (lb)
										Metric Size	Inch Size	
3 3/16	01E BCRET 303 AT	5 13/16	1/4	5 3/4	1 7/8	5	9 3/4	10 1/16	4 (2)	M20	-	44.0
	02 BCRET 303 AT	6 13/16	3/8	6 3/4	3	7 7/8	12 1/8	14	4 7/8	M24	1"	79.2
3 1/4	01E BCRET 304 AT	5 13/16	1/4	5 3/4	1 7/8	5	9 3/4	10 1/16	4 (2)	M20	-	44.0
	02 BCRET 304 AT	6 13/16	3/8	6 3/4	3	7 7/8	12 1/8	14	4 7/8	M24	1"	79.2
3 7/16	100 BCRET 307 AT	5	1/4	5	1 3/4	4 1/4	8 1/2	8 11/16	3 1/2 (2)	M16	-	28.6
	01E BCRET 307 AT	5 13/16	1/4	5 3/4	1 7/8	5	9 3/4	10 1/16	4 (2)	M20	-	44.0
	02 BCRET 307 AT	6 13/16	3/8	6 3/4	3	7 7/8	12 1/8	14	4 7/8	M24	1"	79.2
3 1/2	01E BCRET 308 AT	5 13/16	1/4	5 3/4	1 7/8	5	9 3/4	10 1/16	4 (2)	M20	-	44.0
	02 BCRET 308 AT	6 13/16	3/8	6 3/4	3	7 7/8	12 1/8	14	4 7/8	M24	1"	79.2
3 11/16	01E BCRET 311 AT	5 3/4	1/4	6 3/4	3	7 7/8	12 1/8	14	4 7/8	M24	1"	79.2
	02 BCRET 311 AT	6 3/4	1/2	7 1/2	3 3/8	8 3/4	13 1/8	15 3/8	5 3/8	M30	1 1/8"	114
3 3/4	01E BCRET 312 AT	5 3/4	1/4	6 3/4	3	7 7/8	12 1/8	14	4 7/8	M24	1"	79.2
	02 BCRET 312 AT	6 3/4	1/2	7 1/2	3 3/8	8 3/4	13 1/8	15 3/8	5 3/8	M30	1 1/8"	114
3 15/16	100 BCRET 315 AT	5 13/16	1/4	5 3/4	1 7/8	5	9 3/4	10 1/16	4 (2)	M20	-	41.8
	01E BCRET 315 AT	5 3/4	1/4	6 3/4	3	7 7/8	12 1/8	14	4 7/8	M24	1"	79.2
	02 BCRET 315 AT	6 3/4	1/2	7 1/2	3 3/8	8 3/4	13 1/8	15 3/8	5 3/8	M30	1 1/8"	114
4	100 BCRET 400 AT	5 13/16	1/4	5 3/4	1 7/8	5	9 3/4	10 1/16	4 (2)	M20	-	41.8
	01E BCRET 400 AT	5 3/4	1/4	6 3/4	3	7 7/8	12 1/8	14	4 7/8	M24	1"	79.2
	02 BCRET 400 AT	6 3/4	1/2	7 1/2	3 3/8	8 3/4	13 1/8	15 3/8	5 3/8	M30	1 1/8"	114

Inch-size Rod-end Bearing Units T Type From 4 3/16" To 6" Bore Size

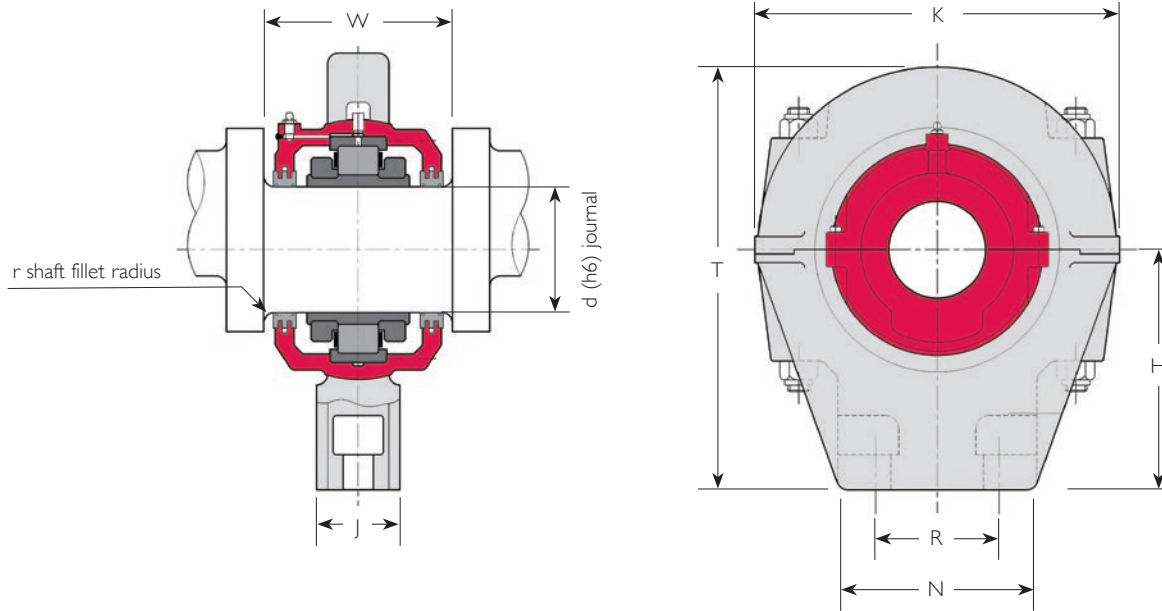

Shaft Diameter d (in)	Reference (1) (Complete Unit)	W (in)	r (max) (in)	N (in)	J (in)	H (in)	K (in)	T (in)	R (in)	Bolts		Mass (Complete Unit) (lb)
										Metric Size	Inch Size	
4 3/16	01 BCRET 403 AT	6 1/16	1/4	7 1/2	3 3/8	8 3/4	13 1/8	15 3/8	5 3/8	M30	1 1/8"	114
	02 BCRET 403 AT	7 3/8	1/2	7 1/2	3 3/8	8 3/4	14 3/4	16 3/4	5 3/8	M30	1 1/8"	143
4 7/16	100 BCRET 407 AT	5 3/4	1/4	6 3/4	3	7 7/8	12 1/8	14	4 7/8	M24	1"	77
	01 BCRET 407 AT	6 1/16	1/4	7 1/2	3 3/8	8 3/4	13 1/8	15 3/8	5 3/8	M30	1 1/8"	114
4 1/2	02 BCRET 407 AT	7 3/8	1/2	7 1/2	3 3/8	8 3/4	14 3/4	16 3/4	5 3/8	M30	1 1/8"	143
	100 BCRET 408 AT	5 3/4	1/4	6 3/4	3	7 7/8	12 1/8	14	4 7/8	M24	1"	77
4 15/16	01 BCRET 408 AT	6 1/16	1/4	7 1/2	3 3/8	8 3/4	13 1/8	15 3/8	5 3/8	M30	1 1/8"	114
	02 BCRET 408 AT	7 3/8	1/2	7 1/2	3 3/8	8 3/4	14 3/4	16 3/4	5 3/8	M30	1 1/8"	143
4 15/16	100 BCRET 415 AT	6 1/16	1/4	7 1/2	3 3/8	8 3/4	13 1/8	15 3/8	5 3/8	M30	1 1/8"	106
	01 BCRET 415 AT	6 5/8	1/4	7 1/2	3 3/8	8 3/4	14 3/4	16 3/4	5 3/8	M30	1 1/8"	143
5	02 BCRET 415 AT	8 1/4	1/2	8	4	11	17 3/8	19 3/4	5 1/2	M30	1 1/4"	218
	100 BCRET 500 AT	6 1/16	1/4	7 1/2	3 3/8	8 3/4	13 1/8	15 3/8	5 3/8	M30	1 1/8"	106
5	01 BCRET 500 AT	6 5/8	1/4	7 1/2	3 3/8	8 3/4	14 3/4	16 3/4	5 3/8	M30	1 1/8"	143
	02 BCRET 500 AT	8 1/4	1/2	8	4	11	17 3/8	19 3/4	5 1/2	M30	1 1/4"	218

- 1) For (matched) rod end and cartridge only without roller bearing remove 'B' from reference, e.g. 01 CRET 407 AT
 For (standard rod-end specification) bearing only remove 'CRET' and 'AT' from reference and add 'GR C2', e.g. 01 B 407 GR C2

- 2) Holes tapped in end face

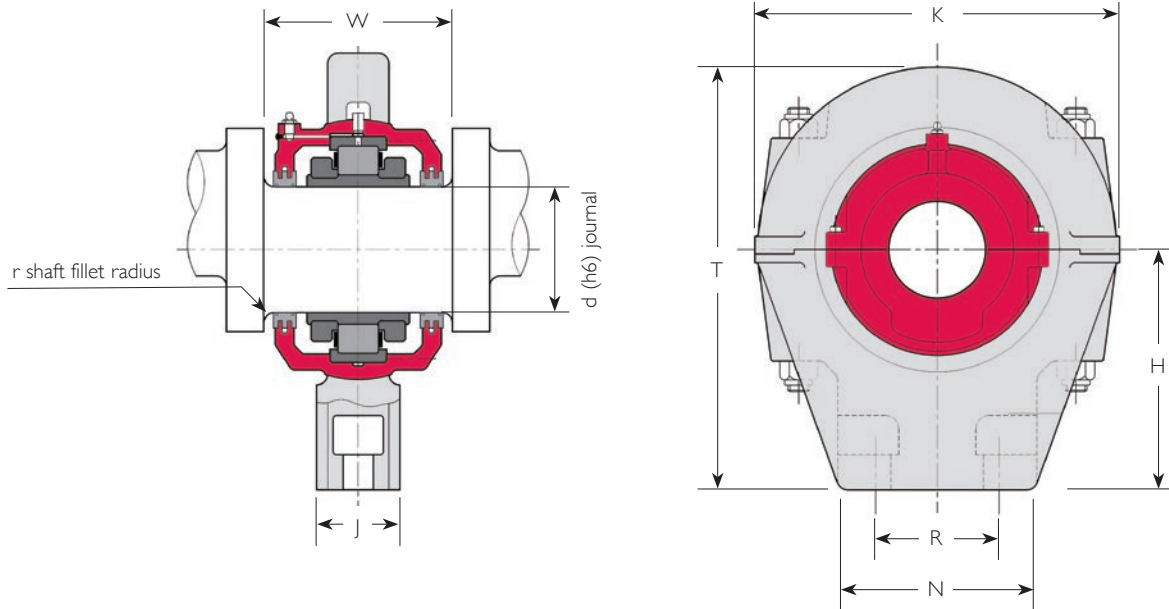

Shaft Diameter d (in)	Reference (l) (Complete Unit)	W (in)	r (max) (in)	N (in)	J (in)	H (in)	K (in)	T (in)	R (in)	Bolts		Mass (Complete Unit) (lb)
										Metric Size	Inch Size	
5 7/16	100 BCRET 507 AT	6 5/8	1/4	7 1/2	3 3/8	8 3/4	14 3/4	16 3/4	5 3/8	M30	1 1/4"	132
	01 BCRET 507 AT	7 3/8	3/8	8	4	11	17 3/8	19 3/4	5 1/2	M30	1 1/4"	196
	02 BCRET 507 AT	8 3/8	1/2	8	4	11	17 1/2	22	5 1/2	M30	1 1/4"	262
5 3/16	01 BCRET 503 AT	7 3/8	3/8	8	4	11	17 3/8	19 3/4	5 1/2	M30	1 1/4"	196
	02 BCRET 503 AT	8 3/8	1/2	8	4	11	17 1/2	22	5 1/2	M30	1 1/4"	262
5 1/2	100 BCRET 508 AT	6 5/8	1/4	7 1/2	3 3/8	8 3/4	14 3/4	16 3/4	5 3/8	M30	1 1/4"	132
	01 BCRET 508 AT	7 3/8	3/8	8	4	11	17 3/8	19 3/4	5 1/2	M30	1 1/4"	196
	02 BCRET 508 AT	8 3/8	1/2	8	4	11	17 1/2	22	5 1/2	M30	1 1/4"	262
5 15/16	100 BCRET 515 AT	7 3/8	3/8	8	4	11	17 3/8	19 3/4	5 1/2	M30	1 1/4"	180
	01 BCRET 515 AT	7 5/8	3/8	8	4	11	17 3/8	19 3/4	5 1/2	M30	1 1/4"	218
	02 BCRET 515 AT	9	1/2	8	4	11	17 1/2	22	5 1/2	M30	1 1/4"	288
6	100 BCRET 600 AT	7 3/8	3/8	8	4	11	17 3/8	19 3/4	5 1/2	M30	1 1/4"	180
	01 BCRET 600 AT	7 5/8	3/8	8	4	11	17 3/8	19 3/4	5 1/2	M30	1 1/4"	218
	02 BCRET 600 AT	9	1/2	8	4	11	17 1/2	22	5 1/2	M30	1 1/4"	288

Inch-size Rod-end Bearing Units Shoe Type From 1 3/16" To 3" Bore Size

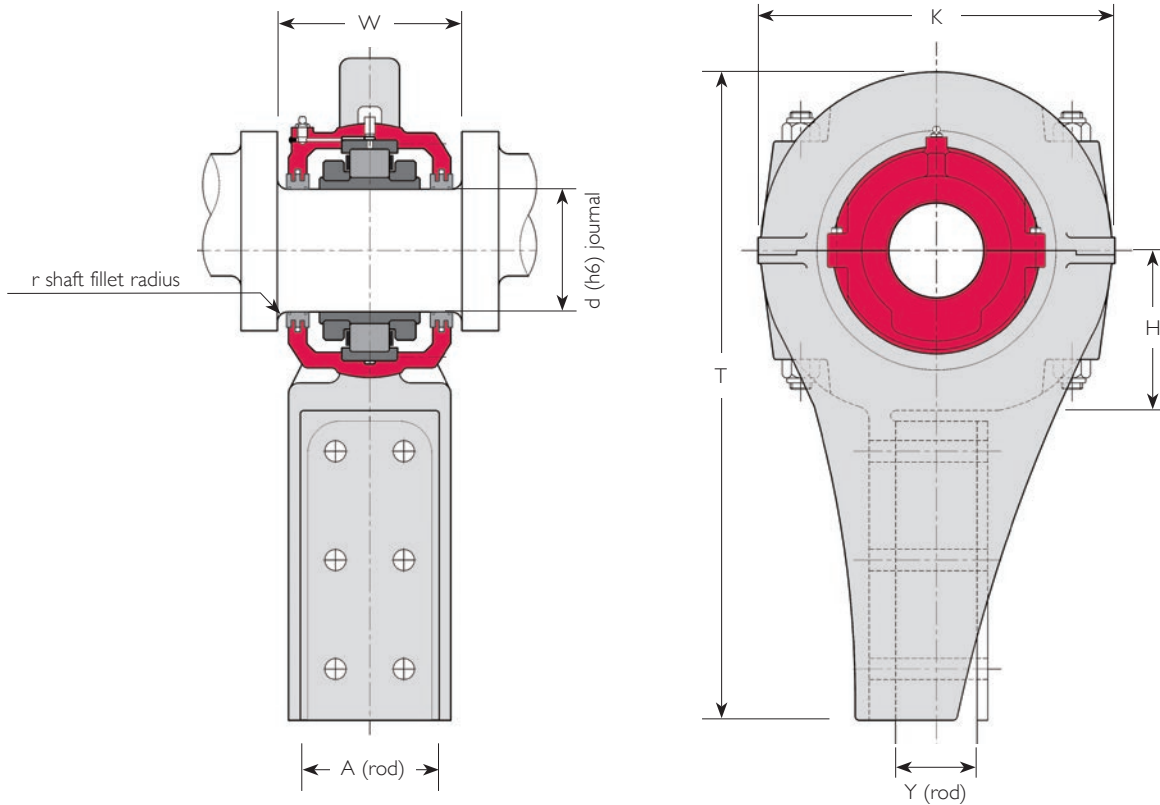

Shaft Diameter d (in)	Reference (1) (Complete Unit)	W (in)	r (max) (in)	A (2) (rod) (in)	Y (2) (rod) (in)	H (in)	K (in)	T (in)	Mass (Complete Unit) (lb)
1 3/16	01 BCRES 103 AT	3 5/8	1/8	2 7/16	3/8	2 1/2	6 5/16	10 3/16	11.0
1 1/4	01 BCRES 104 AT	3 5/8	1/8	2 7/16	3/8	2 1/2	6 5/16	10 3/16	11.0
1 7/16	01 BCRES 107 AT	3 5/8	1/8	2 7/16	3/8	2 1/2	6 5/16	10 3/16	11.0
1 1/2	01 BCRES 108 AT	3 5/8	1/8	2 7/16	3/8	2 1/2	6 5/16	10 3/16	11.0
1 11/16	01E BCRES 111 AT	4 1/16	1/8	2 7/16	3/8	2 3/4	6 9/16	10 3/16	15.4
1 3/4	01E BCRES 112 AT	4 1/16	1/8	2 7/16	3/8	2 3/4	6 9/16	12 1/8	15.4
1 15/16	01E BCRES 115 AT	4 1/16	1/8	2 7/16	3/8	2 3/4	6 9/16	12 1/8	15.4
	02 BCRES 115 AT	4 7/8	3/16	2 7/16	1 1/4	3	7 1/2	13	22.0
2	01E BCRES 200 AT	4 1/16	1/8	2 7/16	3/8	2 3/4	6 9/16	12 1/8	15.4
	02 BCRES 200 AT	4 7/8	3/16	2 7/16	1 1/4	3	7 1/2	13	22.0
2 3/16	01E BCRES 203 AT	4 7/16	3/16	2 7/16	3/8	3 1/8	7 1/2	13	28.6
	02 BCRES 203 AT	5 7/16	1/4	3 1/2	2	4 1/4	9 3/4	17	44.0
2 1/4	01E BCRES 204 AT	4 7/16	3/16	2 7/16	3/8	3 1/8	7 1/2	13	28.6
	02 BCRES 204 AT	5 7/16	1/4	3 1/2	2	4 1/4	9 3/4	17	44.0

1) For (matched) rod end and cartridge only without roller bearing remove 'B' from reference, e.g. 01 CRES 107 AT
 For (standard rod-end specification) bearing only remove 'CRES' and 'AT' from reference and add 'GR C2', e.g. 01 B 107 GR C2

2) Rod fixing varies from 2 to 6 bolts according to size, and can be adapted to requirements

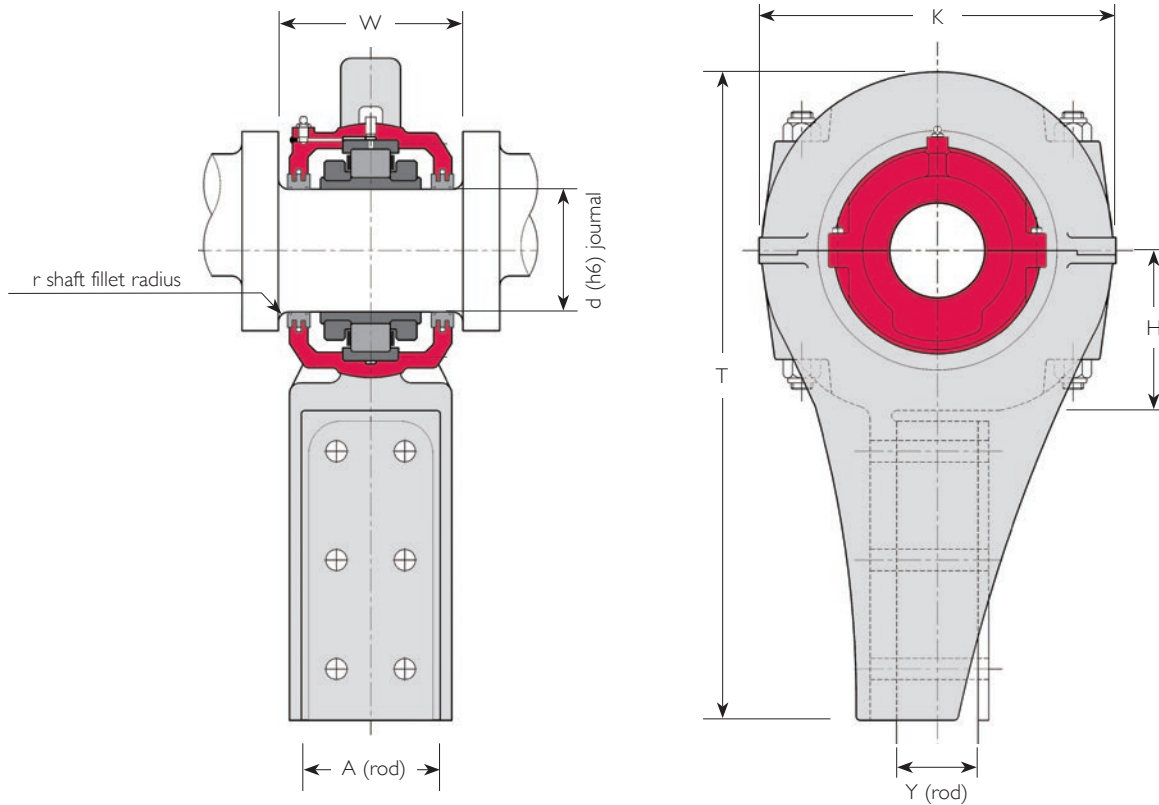

Shaft Diameter d (in)	Reference (1) (Complete Unit)	W (in)	r (max) (in)	A (2) (rod) (in)	Y (2) (rod) (in)	H (in)	K (in)	T (in)	Mass (Complete Unit) (lb)
2 7/16	01E BCRES 207 AT	4 7/16	3/16	2 7/16	3/8	3 1/8	7 1/2	13	28.6
	02 BCRES 207 AT	5 7/16	1/4	3 1/2	2	4 1/4	9 3/4	17	44.0
2 1/2	01E BCRES 208 AT	4 7/16	3/16	2 7/16	3/8	3 1/8	7 1/2	13	28.6
	02 BCRES 208 AT	5 7/16	1/4	3 1/2	2	4 1/4	9 3/4	17	44.0
2 11/16	01E BCRES 211 AT	5	1/4	3 1/2	2	4 1/4	9 3/4	17	48.4
	02 BCRES 211 AT	5 15/16	1/4	4 1/2	1 1/2	5 1/8	9 3/4	21 1/4	88.0
2 3/4	01E BCRES 212 AT	5	1/4	3 1/2	2	4 1/4	9 3/4	17	48.4
	02 BCRES 212 AT	5 15/16	1/4	4 1/2	1 1/2	5 1/8	9 3/4	21 1/4	88.0
2 15/16	100 BCRES 215 AT	4 7/16	3/16	2 7/16	3/8	3 1/8	7 1/2	13	28.6
	01E BCRES 215 AT	5	1/4	3 1/2	2	4 1/4	9 3/4	17	48.4
	02 BCRES 215 AT	5 15/16	1/4	4 1/2	1 1/2	5 1/8	9 3/4	21 1/4	88.0
3	100 BCRES 300 AT	4 7/16	3/16	2 7/16	3/8	3 1/8	7 1/2	13	28.6
	01E BCRES 300 AT	5	1/4	3 1/2	2	4 1/4	9 3/4	17	48.4
	02 BCRES 300 AT	5 15/16	1/4	4 1/2	1 1/2	5 1/8	9 3/4	21 1/4	88.0

1) For (matched) rod end and cartridge only without roller bearing remove 'B' from reference, e.g. 01E CRES 207 AT

For (standard rod-end specification) bearing only remove 'CRES' and 'AT' from reference and add 'GR C2', e.g. 01E B 207 GR C2

2) Rod fixing varies from 2 to 6 bolts according to size, and can be adapted to requirements

Inch-size Rod-end Bearing Units Shoe Type From 3 3/16" To 4 15/16" Bore Size

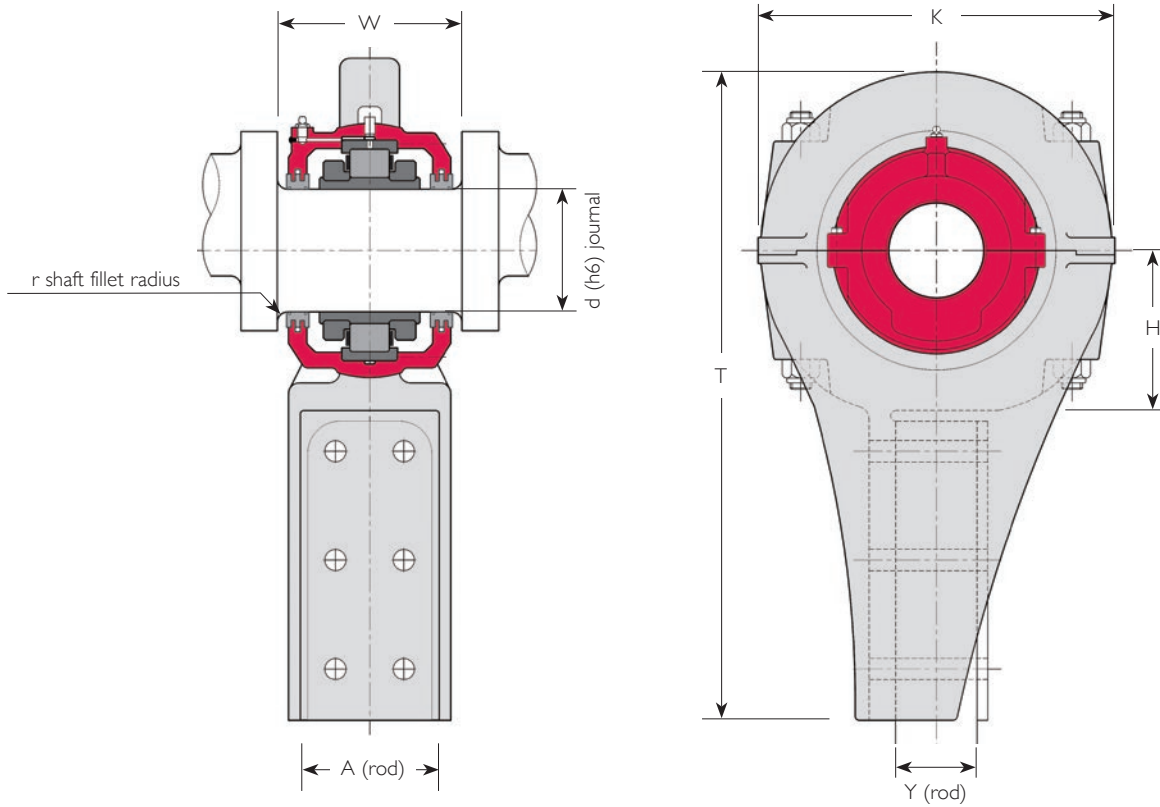

Shaft Diameter d (in)	Reference (1) (Complete Unit)	W (in)	r (max) (in)	A (2) (rod) (in)	Y (2) (rod) (in)	H (in)	K (in)	T (in)	Mass (Complete Unit) (lb)
3 3/16	01E BCRES 303 AT	5 13/16	1/4	3 15/16	2	5 1/4	10 3/8	23 3/4	94.6
	02 BCRES 303 AT	6 13/16	3/8	5	3	5 7/8	13 1/8	24	136
3 1/4	01E BCRES 304 AT	5 13/16	1/4	3 15/16	2	5 1/4	10 3/8	23 3/4	94.6
	02 BCRES 304 AT	6 13/16	3/8	5	3	5 7/8	13 1/8	24	136
3 7/16	100 BCRES 307 AT	5	1/4	3 1/2	2	4 1/4	9 3/4	17	50.6
	01E BCRES 307 AT	5 13/16	1/4	3 15/16	2	5 1/4	10 3/8	23 3/4	94.6
	02 BCRES 307 AT	6 13/16	3/8	5	3	5 7/8	13 1/8	24	136
3 1/2	01E BCRES 308 AT	5 13/16	1/4	3 15/16	2	5 1/4	10 3/8	23 3/4	94.6
	02 BCRES 308 AT	6 13/16	3/8	5	3	5 7/8	13 1/8	24	136
3 11/16	01E BCRES 311 AT	5 3/4	1/4	3 15/16	2 5/16	4 15/16	12 1/8	22 1/2	96.8
	02 BCRES 311 AT	6 3/4	1/2	5	3	5 7/8	13 15/16	24 5/16	156
3 3/4	01E BCRES 312 AT	5 3/4	1/4	3 15/16	2 5/16	4 15/16	12 1/8	22 1/2	96.8
	02 BCRES 312 AT	6 3/4	1/2	5	3	5 7/8	13 15/16	24 5/16	156
3 15/16	100 BCRES 315 AT	5 13/16	1/4	4 1/2	1 1/2	5 1/8	9 3/4	21 1/4	79.2
	01E BCRES 315 AT	5 3/4	1/4	3 15/16	2 5/16	4 15/16	12 1/8	22 1/2	96.8
	02 BCRES 315 AT	6 3/4	1/2	5	3	5 7/8	13 15/16	24 5/16	156

1) For (matched) rod end and cartridge only without roller bearing remove 'B' from reference, e.g. 01 CRES 407 AT

For (standard rod-end specification) bearing only remove 'CRES' and 'AT' from reference and add 'GR C2', e.g. 01 B 407 GR C2

2) Rod fixing varies from 2 to 6 bolts according to size, and can be adapted to requirements

Inch-size Rod-end Bearing Units Shoe Type From 3 3/16" To 4 15/16" Bore Size

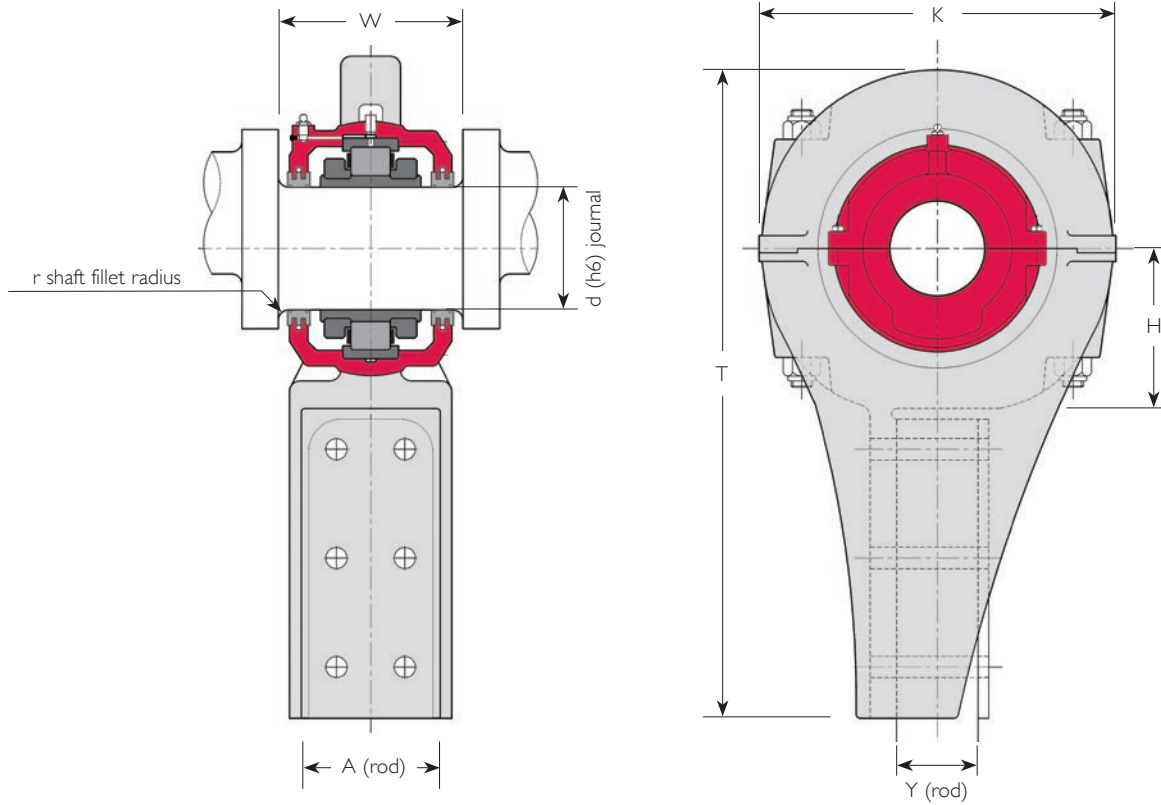

Shaft Diameter d (in)	Reference (1) (Complete Unit)	W (in)	r (max) (in)	A (2) (rod) (in)	Y (2) (rod) (in)	H (in)	K (in)	T (in)	Mass (Complete Unit) (lb)
4	100 BCRES 400 AT	5 13/16	1/4	4 1/2	1 1/2	5 1/8	9 3/4	21 1/4	79.2
	01E BCRES 400 AT	5 3/4	1/4	3 15/16	2 5/16	4 15/16	12 1/8	22 1/2	96.8
	02 BCRES 400 AT	6 3/4	1/2	5	3	5 7/8	13 15/16	24 5/16	156
4 3/16	01 BCRES 403 AT	6 1/16	1/4	5	2 5/16	5 7/8	13 15/16	24 5/16	139
	02 BCRES 403 AT	7 3/8	1/2	5	3	6 3/8	15 3/4	25 3/4	200
4 7/16	100 BCRES 407 AT	5 3/4	1/4	3 15/16	2 5/16	4 15/16	12 1/8	22 1/2	94.6
	01 BCRES 407 AT	6 1/16	1/4	5	2 5/16	5 7/8	13 15/16	24 5/16	139
	02 BCRES 407 AT	7 3/8	1/2	5	3	6 3/8	15 3/4	25 3/4	200
4 1/2	100 BCRES 408 AT	5 3/4	1/4	3 15/16	2 5/16	4 15/16	12 1/8	22 1/2	94.6
	01 BCRES 408 AT	6 1/16	1/4	5	2 5/16	5 7/8	13 15/16	24 5/16	139
	02 BCRES 408 AT	7 3/8	1/2	5	3	6 3/8	15 3/4	25 3/4	200
4 15/16	100 BCRES 415 AT	6 1/16	1/4	5	2 5/16	5 7/8	13 15/16	24 5/16	130
	01 BCRES 415 AT	6 5/8	1/4	5	2 1/2	6 1/4	15 3/4	25 3/4	183
	02 BCRES 415 AT	8 1/4	1/2	6	3	6 15/16	17 3/8	27 3/8	273

Inch-size Rod-end Bearing Units Shoe Type From 5" To 6" Bore Size

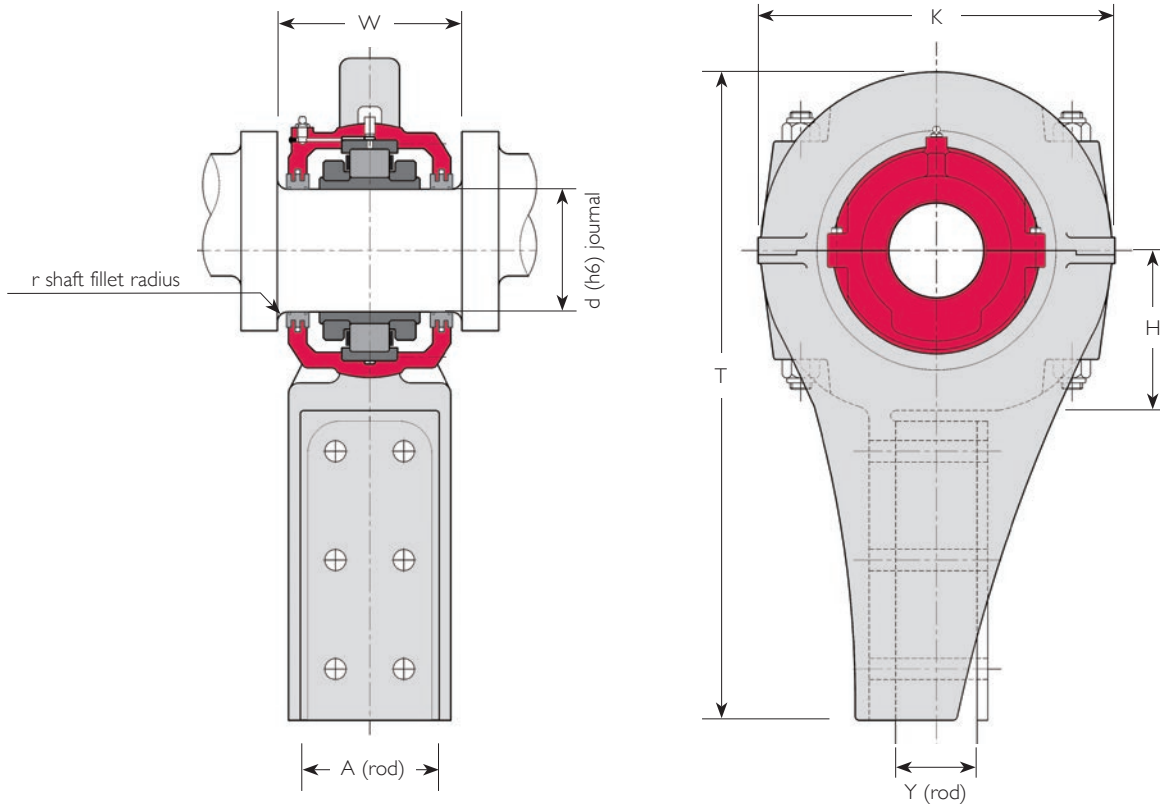

Shaft Diameter d (in)	Reference (1) (Complete Unit)	W (in)	r (max) (in)	A (2) (rod) (in)	Y (2) (rod) (in)	H (in)	K (in)	T (in)	Mass (Complete Unit) (lb)
5	100 BCRES 500 AT	6 1/16	1/4	5	2 5/16	5 7/8	13 15/16	24 5/16	130
	01 BCRES 500 AT	6 5/8	1/4	5	2 1/2	6 1/4	15 3/4	25 3/4	183
	02 BCRES 500 AT	8 1/4	1/2	6	3	6 15/16	17 3/8	27 3/8	273
5 3/16	01 BCRES 503 AT	7 3/8	3/8	6	3	6 15/16	17 3/8	27 3/8	216
	02 BCRES 503 AT	8 3/8	1/2	6	3	6 15/16	17 3/8	27 3/8	319
5 7/16	100 BCRES 507 AT	6 5/8	1/4	5	2 1/2	6 1/4	15 3/4	25 3/4	172
	01 BCRES 507 AT	7 3/8	3/8	6	3	6 15/16	17 3/8	27 3/8	216
	02 BCRES 507 AT	8 3/8	1/2	6	3	6 15/16	17 3/8	27 3/8	319
5 1/2	100 BCRES 508 AT	6 5/8	1/4	5	2 1/2	6 1/4	15 3/4	25 3/4	172
	01 BCRES 508 AT	7 3/8	3/8	6	3	6 15/16	17 3/8	27 3/8	216
	02 BCRES 508 AT	8 3/8	1/2	6	3	6 15/16	17 3/8	27 3/8	319
5 15/16	100 BCRES 515 AT	7 3/8	3/8	6	3	6 15/16	17 3/8	27 3/8	200
	01 BCRES 515 AT	7 5/8	3/8	6	3	6 15/16	17 3/8	27 3/8	235
	02 BCRES 515 AT	9	1/2	6	2 1/2	8	17 1/2	29	365
6	100 BCRES 600 AT	7 3/8	3/8	6	3	6 15/16	17 3/8	27 3/8	200
	01 BCRES 600 AT	7 5/8	3/8	6	3	6 15/16	17 3/8	27 3/8	235
	02 BCRES 600 AT	9	1/2	6	2 1/2	8	17 1/2	29	365

1) For (matched) rod end and cartridge only without roller bearing remove 'B' from reference, e.g. 01 CRES 507 AT
 For (standard rod-end specification) bearing only remove 'CRES' and 'AT' from reference and add 'GR C2', e.g. 01 B 507 GR C2

2) Rod fixing varies from 2 to 6 bolts according to size, and can be adapted to requirements

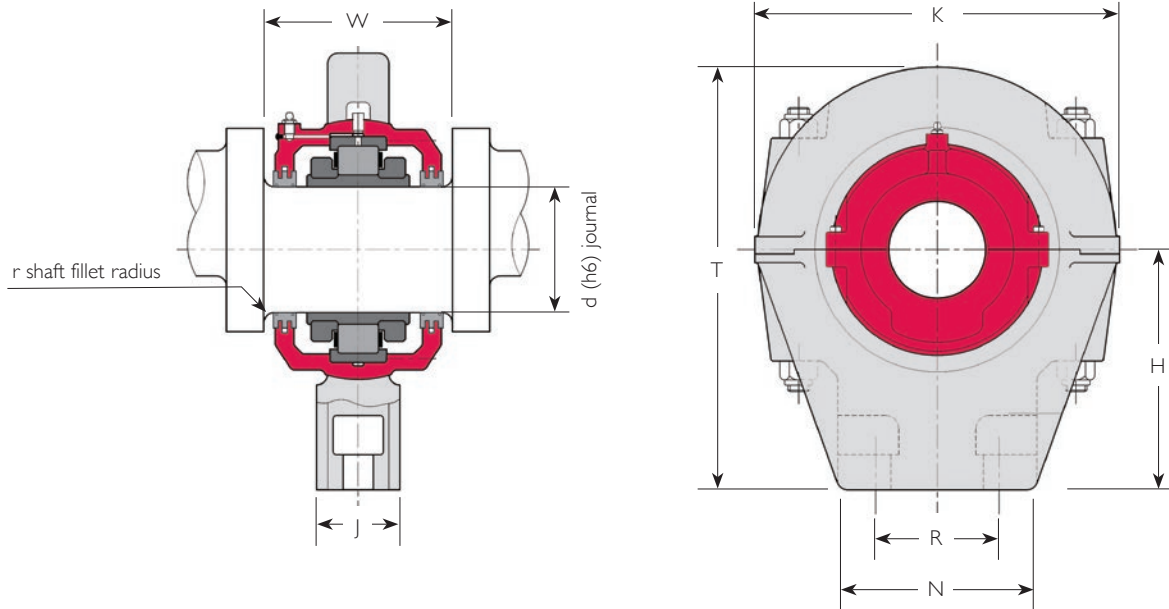

Shaft Diameter d (mm)	Reference (2) (Complete Unit)	W (mm)	r (max) (mm)	N (mm)	J (mm)	H (mm)	K (mm)	T (mm)	R (mm)	Bolts	Mass (Complete Unit) (kg)
40	01 BCRET 40M AT	92	3	86	30	76	140	152	57(1)	M12	6
45	01E BCRET 45M AT	104	3	102	32	102	166	190	70	M10	8
50	01E BCRET 50M AT	104	3	102	32	102	166	190	70	M10	8
	02 BCRET 50M AT	123	4.5	115	38	95	197	194	76(1)	M16	9
60	01E BCRET 60M AT	113	4.5	115	38	95	197	194	76(1)	M16	9
	02 BCRET 60M AT	138	6	128	44	108	216	220	89(1)	M16	13
65	01E BCRET 65M AT	113	4.5	115	38	95	197	194	76(1)	M16	9
	02 BCRET 65M AT	138	6	128	44	108	216	220	89(1)	M16	13
70	01E BCRET 70M AT	126	6	128	44	108	216	220	89(1)	M16	13
	02 BCRET 70M AT	152	6	146	48	127	248	256	102(1)	M20	20
75	100 BCRET 75M AT	113	4.5	115	38	95	197	194	76(1)	M16	9
	01E BCRET 75M AT	126	6	128	44	108	216	220	89(1)	M16	13
	02 BCRET 75M AT	152	6	146	48	127	248	256	102(1)	M20	20
80	01E BCRET 80M AT	148	6	146	48	127	248	256	102(1)	M20	20
	02 BCRET 80M AT	173	9.5	170	76	200	308	356	124	M24	36

1) Holes tapped in end face

2) For (matched) rod end and cartridge only without roller bearing remove 'B' from reference, e.g. 02 CRET 65M AT

For (standard rod-end specification) bearing only remove 'CRET' and 'AT' from reference and add 'GR C2', e.g. 02 B 65M GR C2

Metric Rod-end Bearing Units T Type From 85mm To 155mm Bore Size

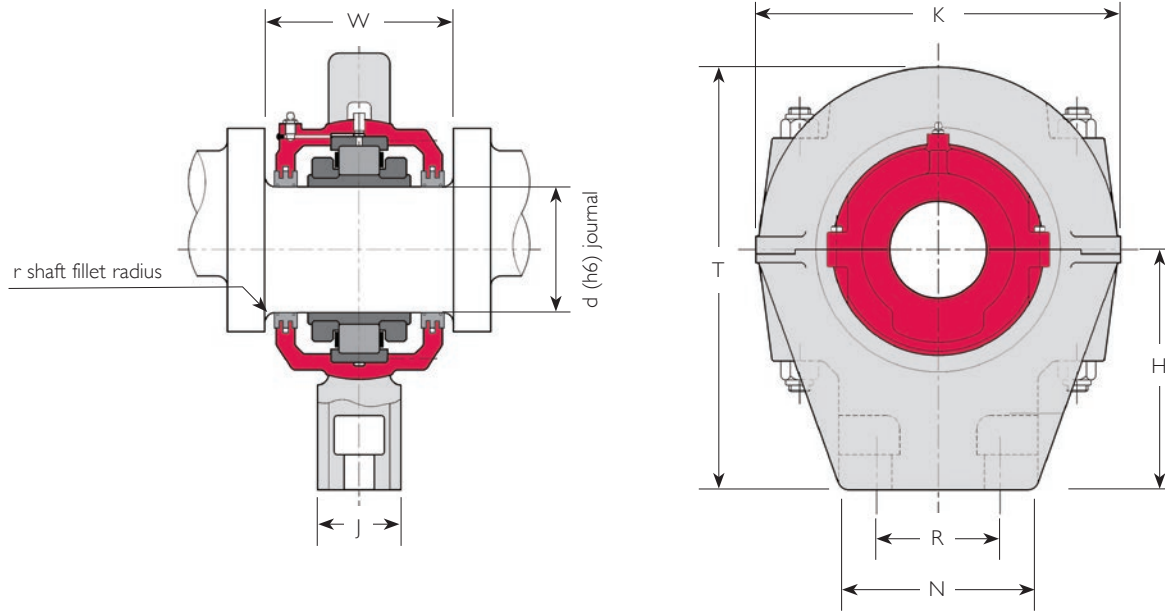

Shaft Diameter d (mm)	Reference (2) (Complete Unit)	W (mm)	r (max) (mm)	N (mm)	J (mm)	H (mm)	K (mm)	T (mm)	R (mm)	Bolts	Mass (Complete Unit) (kg)
85	100 BCRET 85M AT	126	6	128	44	108	216	220	89(1)	M16	13
	01E BCRET 85M AT	148	6	146	48	127	248	256	102(1)	M20	20
	02 BCRET 85M AT	173	9.5	170	76	200	308	356	124	M24	36
90	01E BCRET 90M AT	148	6	146	48	127	248	256	102(1)	M20	20
	02 BCRET 90M AT	173	9.5	170	76	200	308	356	124	M24	36
100	100 BCRET 100M AT	148	6	146	48	127	248	256	102(1)	M20	20
	01E BCRET 100M AT	146	6	170	76	200	308	356	124	M24	36
	02 BCRET 100M AT	171	12.5	190	86	222	334	390	136	M30	52
105	01E BCRET 105M AT	146	6	170	76	200	308	356	124	M24	36
	02 BCRET 105M AT	171	12.5	190	86	222	334	390	136	M30	52
110	100 BCRET 110M AT	146	6	170	76	200	308	356	124	M24	36
	01 BCRET 110M AT	154	6	190	86	222	334	390	136	M30	52
	02 BCRET 110M AT	187	12.5	190	86	222	375	425	136	M30	65
115	01 BCRET 115M AT	154	6	190	86	222	334	390	136	M30	52
	02 BCRET 115M AT	187	12.5	190	86	222	375	425	136	M30	65

1) Holes tapped in end face

2) For (matched) rod end and cartridge only without roller bearing remove 'B' from reference, e.g. 01 CRET 110M AT

For (standard rod-end specification) bearing only remove 'CRET' and 'AT' from reference and add 'GR C2', e.g. 01 B 110M GR C2

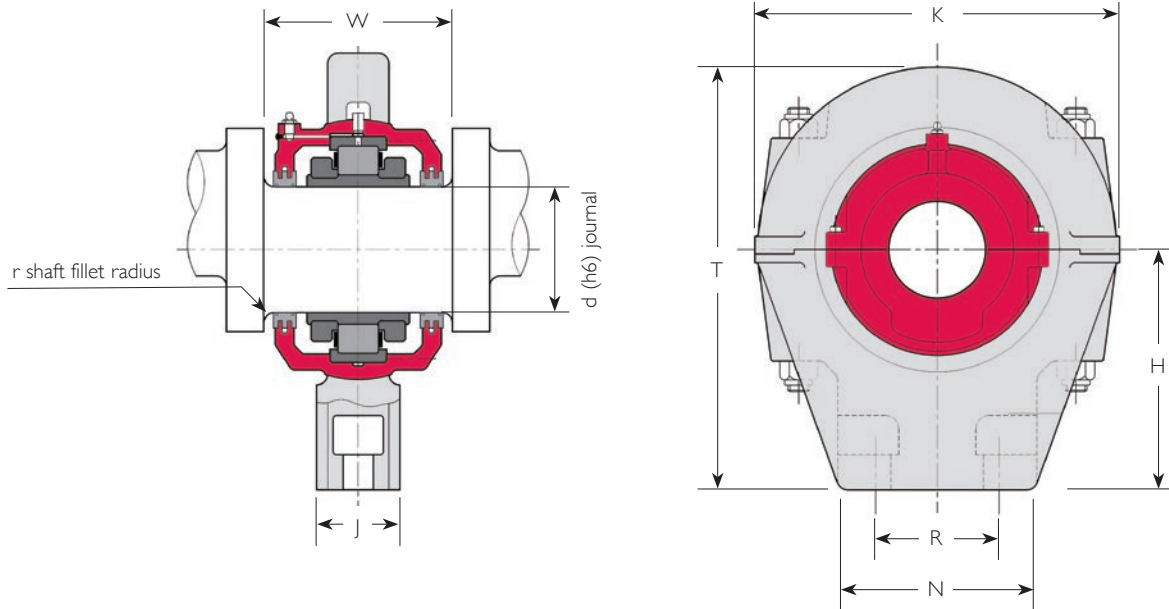

Shaft Diameter d (mm)	Reference (2) (Complete Unit)	W (mm)	r (max) (mm)	N (mm)	J (mm)	H (mm)	K (mm)	T (mm)	R (mm)	Bolts	Mass (Complete Unit) (kg)
120	100 BCRET 120M AT	154	6	190	86	222	334	390	136	M30	48
	01 BCRET 120M AT	168	6	190	86	222	375	425	136	M30	65
	02 BCRET 120M AT	209	12.5	204	102	279	442	502	140	M30	99
125	01 BCRET 125M AT	168	6	190	86	222	375	425	136	M30	65
	02 BCRET 125M AT	209	12.5	204	102	279	442	502	140	M30	99
130	100 BCRET 130M AT	154	6	190	86	222	334	390	136	M30	48
	01 BCRET 130M AT	168	6	190	86	222	375	425	136	M30	65
	02 BCRET 130M AT	209	12.5	204	102	279	442	502	140	M30	99
135	01 BCRET 135M AT	187	9.5	204	102	279	442	502	140	M30	89
140	100 BCRET 140M AT	168	6	190	86	222	375	425	136	M30	60
	01 BCRET 140M AT	187	9.5	204	102	279	442	502	140	M30	89
	02 BCRET 140M AT	213	12.5	204	102	279	445	558	140	M30	119
150	100 BCRET 150M AT	187	9.5	204	102	279	442	502	140	M30	82
	01 BCRET 150M AT	193	9.5	204	102	279	442	502	140	M30	99
	02 BCRET 150M AT	229	12.5	204	102	279	445	558	140	M30	131
155	01 BCRET 155M AT	193	9.5	204	102	279	442	502	140	M30	99
	02 BCRET 155M AT	229	12.5	204	102	279	445	558	140	M30	131

Metric Rod-end Bearing Units Shoe Type From 40mm To 115mm Bore Size

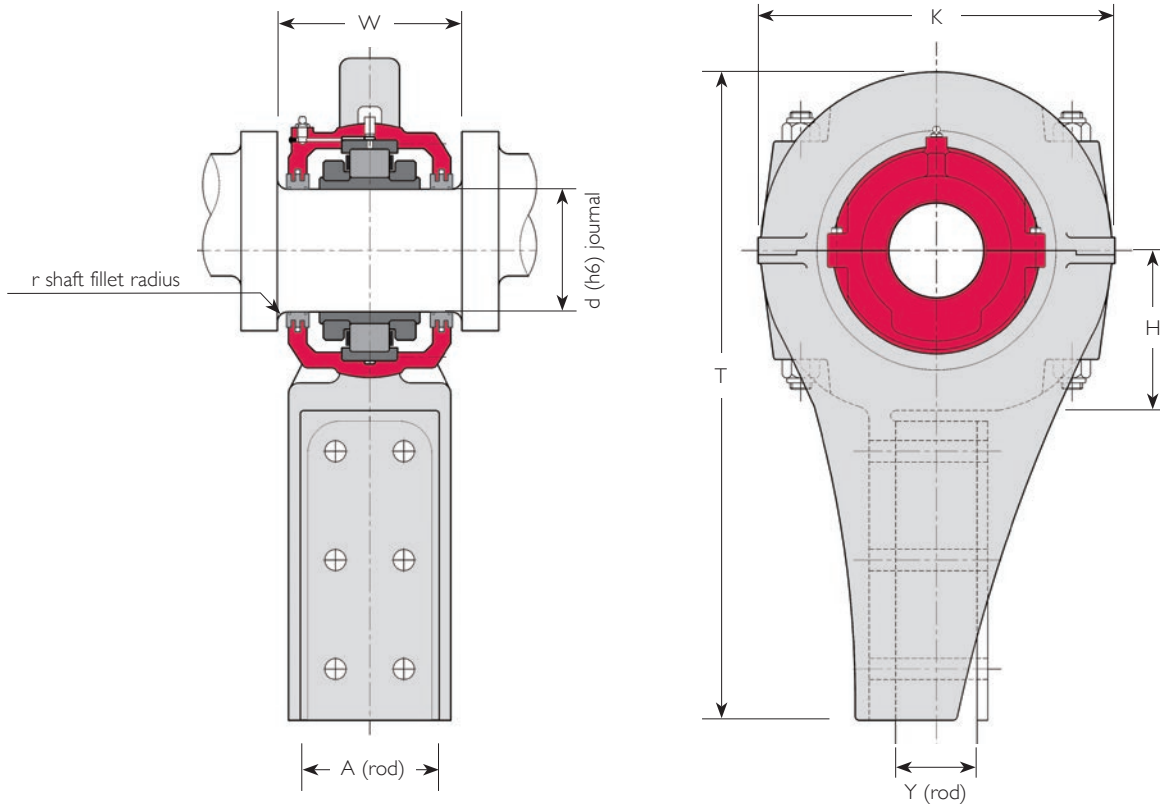

Shaft Diameter d (mm)	Reference (1) (Complete Unit)	W (mm)	r (max) (mm)	A (2) (rod) (mm)	Y (2) (rod) (mm)	H (mm)	K (mm)	T (mm)	Mass (Complete Unit) (kg)
40	01 BCRES 40M AT	92	3	62	10	65	160	258	5
45	01E BCRES 45M AT	104	3	62	10	70	166	308	7
50	01E BCRES 50M AT	104	3	62	10	70	166	308	7
	02 BCRES 50M AT	123	4.5	62	32	76	190	330	10
60	01E BCRES 60M AT	113	4.5	62	10	79	190	330	13
	02 BCRES 60M AT	138	6	88	50	108	248	432	20
65	01E BCRES 65M AT	113	4.5	62	10	79	190	330	13
	02 BCRES 65M AT	138	6	88	50	108	248	432	20
70	01E BCRES 70M AT	126	6	88	50	108	248	432	22
	02 BCRES 70M AT	152	6	114	38	130	248	540	40
75	100 BCRES 75M AT	113	4.5	62	10	79	190	330	13
	01E BCRES 75M AT	126	6	88	50	108	248	432	22
	02 BCRES 75M AT	152	6	114	38	130	248	540	40
80	01E BCRES 80M AT	148	6	100	50	133	264	602	43
	02 BCRES 80M AT	173	9.5	126	76	149	334	610	62

1) For (matched) rod end and cartridge only without roller bearing remove 'B' from reference, e.g. 01 CRES 110M AT

For (standard rod-end specification) bearing only remove 'CRES' and 'AT' from reference and add 'GR C2', e.g. 01 B 110M GR C2

2) Rod fixing varies from 2 to 6 bolts according to size, and can be adapted to requirements

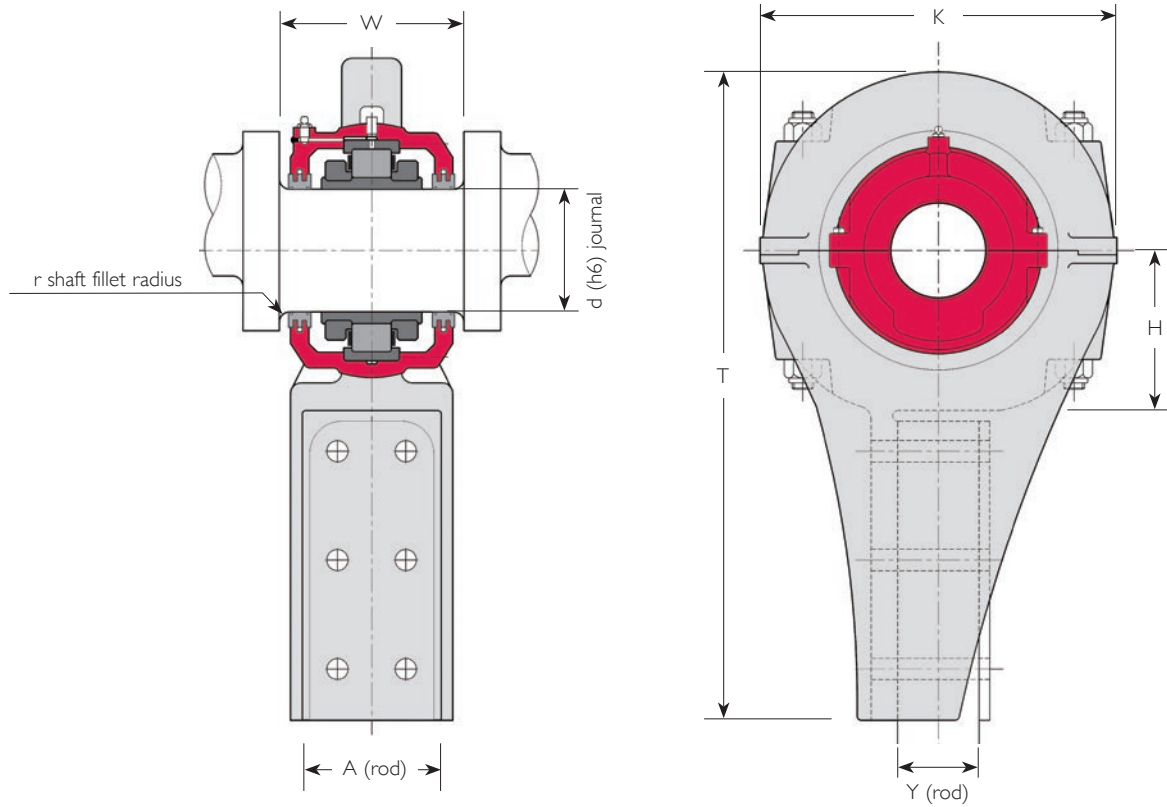

Shaft Diameter d (mm)	Reference (1) (Complete Unit)	W (mm)	r (max) (mm)	A (2) (rod) (mm)	Y (2) (rod) (mm)	H (mm)	K (mm)	T (mm)	Mass (Complete Unit) (kg)
85	100 BCRES 85M AT	126	6	88	50	108	248	432	23
	01E BCRES 85M AT	148	6	100	50	133	264	602	43
	02 BCRES 85M AT	173	9.5	126	76	149	334	610	62
90	01E BCRES 90M AT	148	6	100	50	133	264	602	43
	02 BCRES 90M AT	173	9.5	126	76	149	334	610	62
100	100 BCRES 100M AT	148	6	114	38	130	248	540	36
	01E BCRES 100M AT	146	6	100	58	125	308	572	44
	02 BCRES 100M AT	171	12.5	126	76	149	354	618	71
105	01E BCRES 105M AT	146	6	100	58	125	308	572	44
	02 BCRES 105M AT	171	12.5	126	76	149	354	618	71
110	100 BCRES 110M AT	146	6	100	58	125	308	572	43
	01 BCRES 110M AT	154	6	126	58	149	354	618	63
	02 BCRES 110M AT	187	12.5	126	76	162	400	654	91
115	01 BCRES 115M AT	154	6	126	58	149	354	618	63
	02 BCRES 115M AT	187	12.5	126	76	162	400	654	91

Metric Rod-end Bearing Units Shoe Type From 120mm To 155mm Bore Size

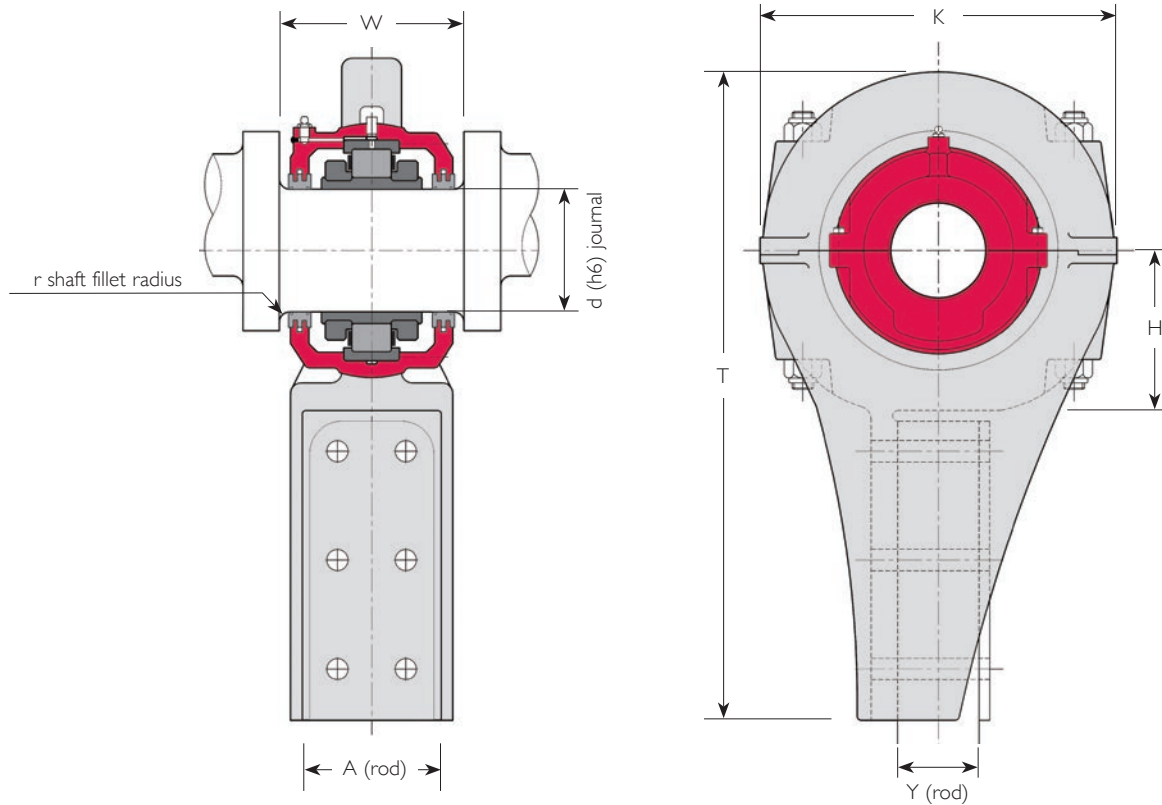

Shaft Diameter d (mm)	Reference (1) (Complete Unit)	W (mm)	r (max) (mm)	A (2) (rod) (mm)	Y (2) (rod) (mm)	H (mm)	K (mm)	T (mm)	Mass (Complete Unit) (kg)
120	100 BCRES 120M AT	154	6	126	58	149	354	618	59
	01 BCRES 120M AT	168	6	126	64	158	400	654	83
	02 BCRES 120M AT	209	12.5	152	76	177	442	696	124
125	01 BCRES 125M AT	168	6	126	64	158	400	654	83
	02 BCRES 125M AT	209	12.5	152	76	177	442	696	124
130	100 BCRES 130M AT	154	6	126	58	149	354	610	59
	01 BCRES 130M AT	168	6	126	64	158	400	654	83
	02 BCRES 130M AT	209	12.5	152	76	177	442	696	124
135	01 BCRES 135M AT	187	9.5	152	76	177	442	696	98

1) For (matched) rod end and cartridge only without roller bearing remove 'B' from reference, e.g. 01 CRES 125M AT

For (standard rod-end specification) bearing only remove 'CRES' and 'AT' from reference and add 'GR C2', e.g. 01 B 125M GR C2

2) Rod fixing varies from 2 to 6 bolts according to size, and can be adapted to requirements

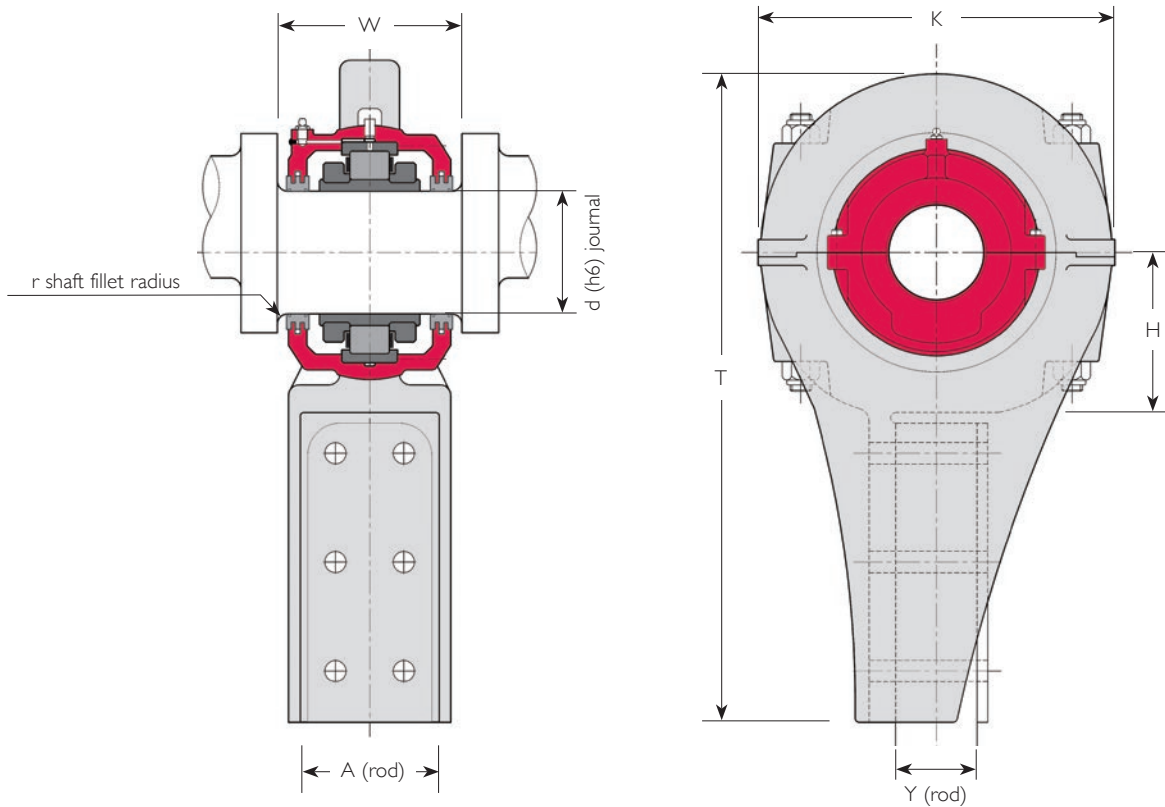

Shaft Diameter d (mm)	Reference (1) (Complete Unit)	W (mm)	r (max) (mm)	A (2) (rod) (mm)	Y (2) (rod) (mm)	H (mm)	K (mm)	T (mm)	Mass (Complete Unit) (kg)
140	100 BCRES 140M AT	168	6	126	64	158	400	654	78
	01 BCRES 140M AT	187	9.5	152	76	177	442	696	98
	02 BCRES 140M AT	213	12.5	152	76	177	442	696	145
150	100 BCRES 150M AT	187	9.5	152	76	177	442	696	91
	01 BCRES 150M AT	193	9.5	152	76	177	442	696	107
	02 BCRES 150M AT	229	12.5	152	64	203	444	736	166
155	01 BCRES 155M AT	193	9.5	152	76	177	442	696	107
	02 BCRES 155M AT	229	12.5	152	64	203	444	736	166

BEARINGS OF LARGE BORE SIZE

The following table lists some of the bearings over 24"/600mm bore size manufactured by Cooper recently.

This table may be used as a guide for selecting or designing-in large bore bearings, but it should be borne in mind that these larger sizes of bearing are frequently adapted to meet application requirements. They may be modified to match existing or required envelopes and capacities. Many of the bearings may be supplied with slightly different bore sizes to those under which they are listed, while alternative versions may already be available at some bore sizes without modification.

Generally, these bearing are available in expansion 'EX' or fixed 'GR' types (see page 4). Extra-expansion 'EXILOG' types (see page 6) are also made regularly, but often have different envelope dimensions (in particular, the inner race is usually wider).

Lighter duty 04 series bearings are shown separately on page 152.

It is always advisable to contact Cooper when specifying large bearings.

HOUSINGS

If the bearing is to be mounted in a housing made by the equipment manufacturer, Cooper will supply details of the required mounting tolerances upon request.

If the bearing is to be fitted into an existing housing, accurate details of the mounting dimensions should be supplied to Cooper to insure compatibility.

Cooper can supply suitable housings, including cartridges, pillow blocks, flanges, and custom housings for large bearings. (See other sections for explanations of these housing types). Please contact Cooper with application details so that we can supply details of the most suitable housing, or design or adapt a housing to suit if required.

DOUBLE BEARINGS

Large bearings are often paired to form a 'double bearing' of increased capacity.

To calculate the dynamic capacity of a double bearing, multiply the dynamic capacity (C_r) of the single bearing by 1.714.

To calculate the static capacity of the double bearing, multiply the static capacity (C_{or}) of the single bearing by 2.

Mountings for double bearings should be designed to equalize the loading on the two rows of rollers.

Bearings should only be mounted together to form a two-row bearing if they are supplied by Cooper specifically for this purpose, and the bearings should be maintained in their allocated pairings.

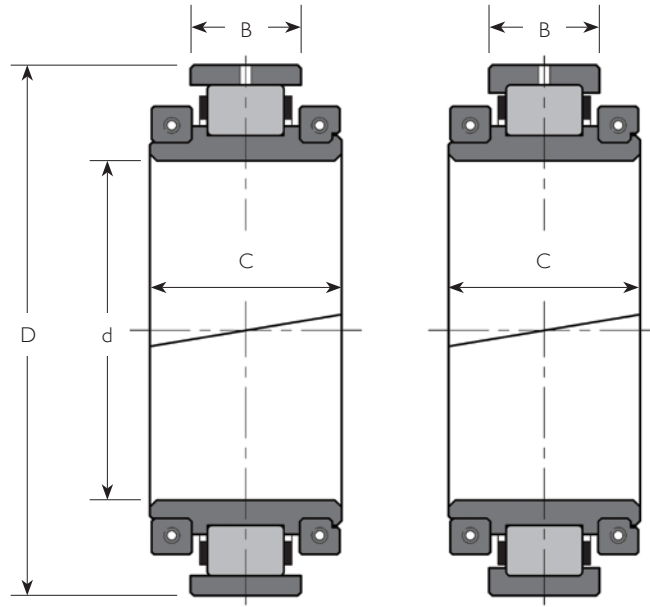

Shaft Diameter d		Reference	D (in)	C (in)	B (in)	Cr (in)	Cor (in)
(in)	(mm)						
	610	01 B 610M	30.709	6.772	3.311	321700	744300
	630	01 B 630M	31.260	7.48	3.46	400000	940000
25		02 B 2500	34.125	8.63	4.63	612000	1311000
	650	02 B 650M	33.858	8.66	4.72	612000	1311000
		03E B 650M	38.583	12.60	7.87	1290000	2529000
	660	02 B 660M	34.125	8.63	4.63	612000	1311000
26		03E B 2600	38.583	12.60	7.87	1290000	2529000
27		01 B 2700	34.016	6.69	3.70	396000	902000
	690	01 B 690M	34.016	6.69	3.70	396000	902000
	710	01 B 710M	35.039	7.28	3.74	408000	952000
		02 B 710M	38.583	11.42	6.10	793000	1578000
28		01 B 2800	35.125	7.25	3.44	378000	908000

Shaft Diameter d		Reference	D (in)	C (in)	B (in)	Cr (in)	Cor (in)
(in)	(mm)						
	750	01 B 750M	38.250	8.11	4.00	522000	1278000
		02 B 750M	38.976	9.45	5.51	799000	1704000
		03 B 750M	41.732	12.20	7.28	1163000	2370000
	775	01 B 775M	37.205	6.50	3.15	396000	893000
	850	01 B 850M	41.181	7.87	4.17	574000	1439000
	950	01 B 950M	46.142	8.66	4.72	728000	1845000
40		01 B 4000	50.000	10.24	5.50	890000	2267000
	1150	4DS B 1150M	58.661	12.01	6.89	1290000	3022000

04 SERIES BEARINGS

Cooper 04 Series bearings are specialized bearings for lighter duties at large bore sizes.

04 Series bearings are capable of high speeds, but are also used on lower speed applications. Use of these bearings at high speeds requires special attention to lubrication.

If the bearing is to be used at slow speeds only it may be possible to omit some of the 'high speed' features of the bearing, allowing a more economical bearing specification.

Shaft Diameter d		Reference	D (in)	C (in)	B (in)	Cr (in)	Cor (in)	Max.Speed (rpm)	Mass (lb)
(in)	(mm)								
6		04 B 600	10.125	3.11	1.50	44500	55300	3000	30
10 5/8		04 B 1010	14.375	4.06	1.91	75500	82500	2470	60
	340	04 B 340M	17.250	4.06	1.91	58700	63400	1950	77
13 1/2		04 B 1308	17.250	4.06	1.91	58700	63400	1950	75
	400	04 B 400M	19.882	3.94	1.42	48100	52800	1650	75
17 1/2		04 B 1708	21.500	4.25	1.91	67900	82500	1460	100
18 1/2		04 B 1808	22.500	4.25	1.91	71000	88800	1370	110
20 3/4		04 B 2012	25.000	4.49	1.91	73300	95100	1210	120
	550	04 B 550M	25.787	3.86	1.42	59800	65000	1150	120
22		04 B 2200	26.250	3.98	1.50	81100	101600	1130	120
23		04 B 2300	27.250	3.98	1.50	82700	105600	1080	130
24		04 B 2400	28.250	3.98	1.50	92800	122100	1020	135
26 1/2		04 B 2608	30.750	4.49	1.91	114400	183900	910	170
30		04 B 3000	34.750	4.49	1.75	83600	114400	780	210
32		04 B 3200	37.000	4.49	1.75	88600	130100	730	230
33		04 B 3300	38.000	4.49	1.75	90600	135300	705	239
36		04 B 3600	41.000	4.49	1.75	94000	125000	620	260
	1060	04 B 1060M	48.031	5.00	2.36	214400	330900	560	395
44		04 B 4400	51.000	6.61	3.00	301000	409500	140	440
48		04 B 4800	54.000	5.51	2.75	245900	380500	350	322
	1295	04 B 1295AM	56.500	5.00	2.50	222100	361000	340	425
	1295	04 B 1295BM	58.000	6.61	3.00	411600	646700	120	690
	1550	04 B 1550M	67.717	5.51	2.95	306600	543500	300	741

Generally, these bearings are available in expansion 'EX' or fixed 'GR' types (see page 4). Alternative configurations are possible where appropriate.

These bearings may be subjected to a degree of adaption to suit application requirements. They may also be supplied with slightly different bore sizes to those under which they are listed.

It is advisable to contact Cooper when specifying 04 Series bearings.

HOUSING

Most commonly, 04 Series bearings are mounted in customer's own housings or into housings integrated into the structure of the machine. Details of appropriate mounting tolerances can be supplied on request.

If it is wished for Cooper to supply bearings complete with housings, please contact us with application details.

In general, if operating conditions and envelope restrictions allow, it is more economical to supply 01 Series bearings complete with housings, as a greater range of standardized housings is available for the 01 Series.

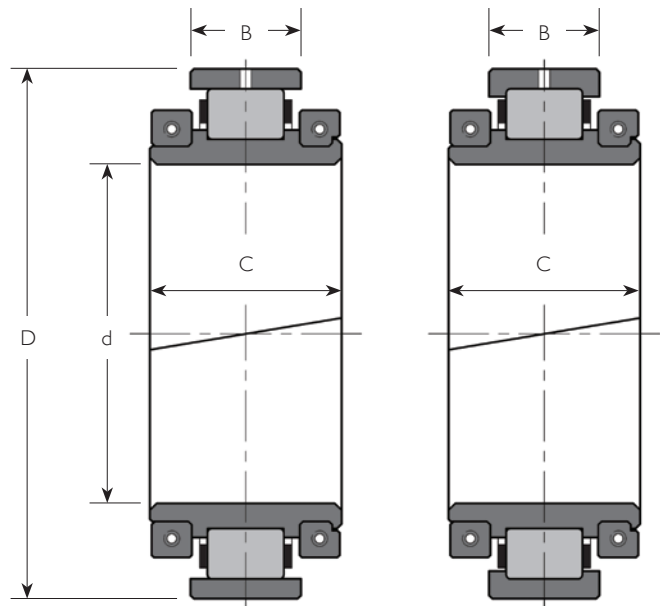

Water-cooled bearing units for continuous casting machines are generally customized to individual applications. Bearings are of the 071 or 081 Series, which are designed specifically for this type of application. The general features of a typical design are illustrated below.

Bearings of the type illustrated may also be applied to other

slow moving applications (generally under 15 rpm) where a high capacity bearing is required in a compact envelope.

If you wish to specify Cooper water-cooled bearing units, or bearings of the 071 or 081 Series, please contact our technical department with details of the application.

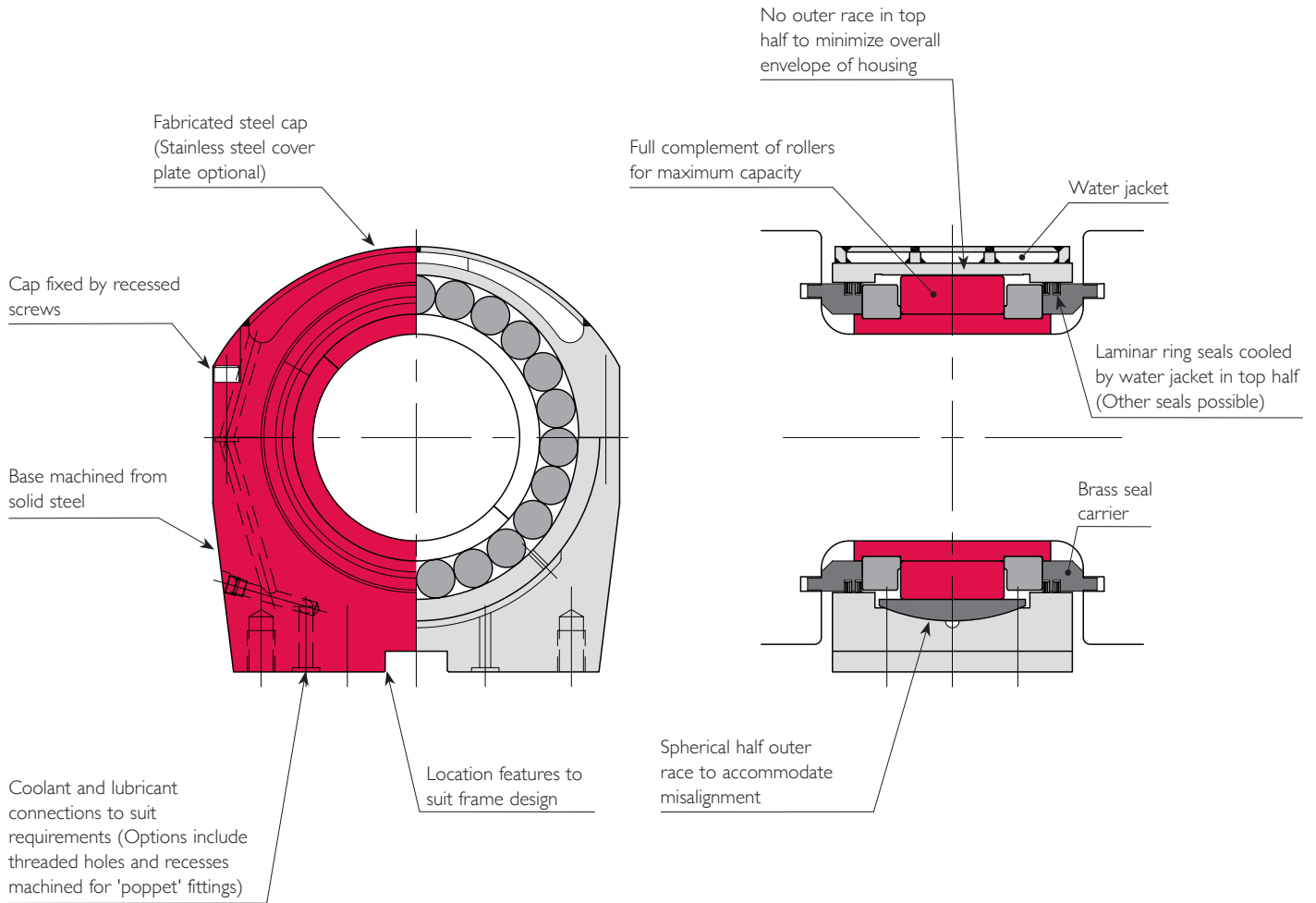

Cooper frequently supply special and customized bearings and housings. Customizations range from minor modifications, such as special holes for mounting instruments, to complete custom bearings and housing.

We have designs and tooling for many products that are not included in this catalog and may suit your application. If not, we are able to design special units as required.

If you do not find a bearing or housing that meets your requirements in this catalog, our technical department will be pleased to advise on a suitable product.

A selection of special products are illustrated on this page.

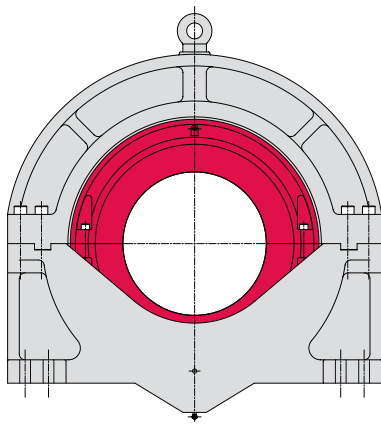

Bearing and cartridge in custom housing
(to be mounted on 2 plinths)

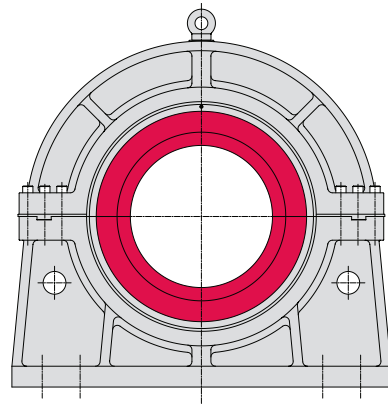

Double bearing in special cartridge and pillow block

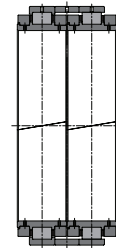
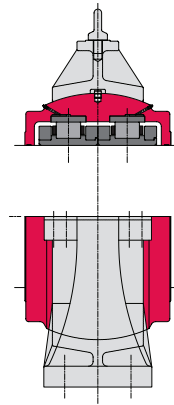

Double bearing to special dimensions with spacer ring for outer race

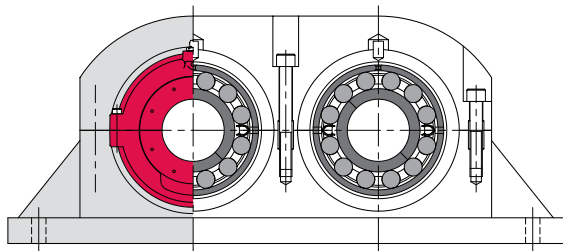

Custom double housing

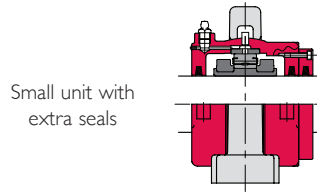

Small unit with extra seals

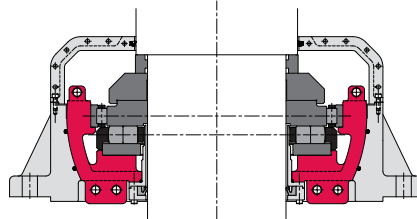

Combined radial and thrust bearing and housing

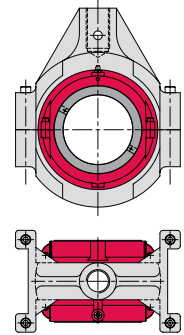

Special compact take-up unit

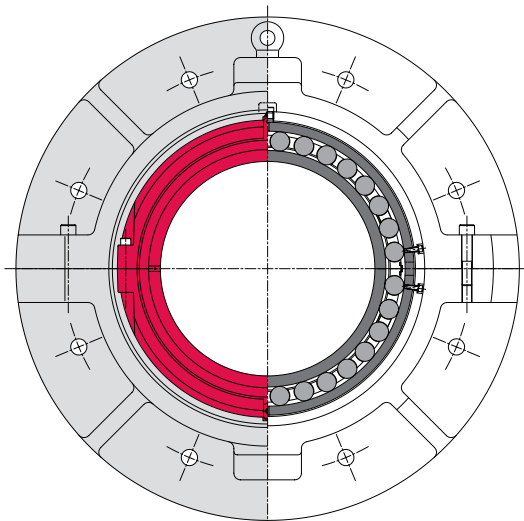

Large flange unit



Solid flat thrust bearing



Split flat thrust bearing

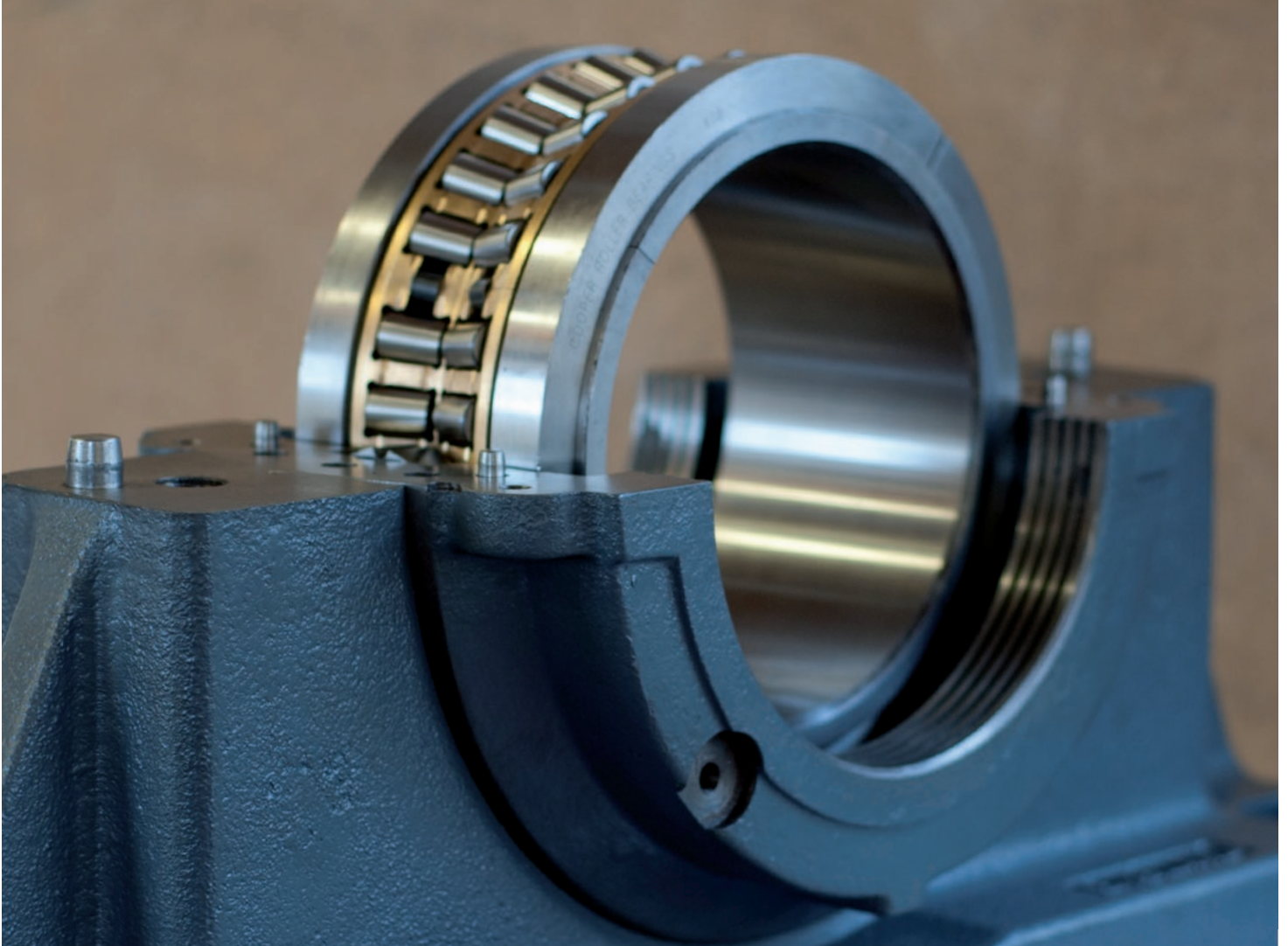

SPLIT TAPERED BEARINGS

INTRODUCTION

The Cooper split tapered bearing is intended for the 'fixed' bearing position of shafts where there is both radial and axial loading and our 'GR' type cylindrical bearing is unsuitable. It is constructed with two rows of opposed rollers to take axial loading in either direction.

Cooper split tapered roller bearings are usually mounted in a cartridge in a similar way to Cooper cylindrical bearings. Cartridges for tapered bearings are machined with grease groove seals as standard and provision made for a temperature element. Alternative seal types are available (see pages 4 and 5), and flange-mounted units may be supplied with bulkhead sealing

arrangements. The proximity of the temperature element hole to the shaft means that if it is of a headed type, generally it will have to have a cranked probe. Alternative positions for the temperature element are possible.

The cartridge is mounted by its spherical seat in an outer housing. Various housing types are available, as for cylindrical bearings, but the most common types are the pedestal and flange. The Cooper technical department should be consulted to confirm housing strength against the anticipated loads before finalizing selection. Ductile iron housings are generally used with these bearings, as indicated by the part numbers listed on the following pages.

BEARING SELECTION

Bearing ratings for dynamic radial capacity (C_r) and static radial capacity (C_{or}) shown in this catalog are in accordance with ISO 281-1990 and ISO 76-1987 respectively.

Radial and axial loads must be considered together as combined 'equivalent loads', as explained below. Generally, maximum instantaneous loading is governed by housing strength rather than bearing static capacity.

DYNAMIC RATING

Expected bearing life is calculated by the following equation:

$$L_{10} = [C_r / (P \times f_d)]^{(10/3)}$$

where:

L_{10} = expected life of 90% of similar bearings under similar operating conditions

C_r = radial dynamic rating

P = equivalent dynamic load

f_d = dynamic or service factor; generally from 1 for steady loading to 3.5 for heavy shock, reciprocation or vibration

The dynamic equivalent load is calculated as follows:

$$\text{when } F_a/F_r \leq e : P = F_r + Y_1 F_a$$

$$\text{when } F_a/F_r > e : P = 0.67 F_r + Y_2 F_a$$

where:

F_r = applied radial load

F_a = applied axial load

and calculation factors Y_1, Y_2 and e are given in the product data tables.

LIFE CALCULATION WITH MULTIPLE LOAD CONDITIONS

Where varying loads are experienced in operation, using the maximum load condition may lead to an unrealistically low calculated life. For n load conditions constituting the full load cycle (at constant speed), an overall dynamic equivalent load may be calculated as follows:

$$P \left[\sum_{i=1}^{i=n} P_i^{(10/3)} p_i \right]^{0.3}$$

where:

P_i = dynamic equivalent load under load condition i

p_i = proportion of time load condition i is applicable

Where the load is continuously variable it may be broken down into a discrete approximation to the actual load cycle.

MINIMUM LOADING

In order to avoid excessive skidding of the rollers, sufficient loading must be applied to the bearing, as follows:

$$P \geq 0.01 C_r$$

ASSEMBLY

The assembly procedure for a Cooper split tapered roller bearing unit is substantially similar to that of a cylindrical bearing and housing. However, some additional points need to be drawn to the attention of the fitter and a full set of assembly instructions for

split tapered bearings should be referred to before commencing installation. This may be obtained in electronic form from the Cooper technical department.

GREASE QUANTITY FOR INITIAL LUBRICATION

The quantity of grease required on initial lubrication is dependent upon operating speed and temperature.

If the operating temperature is below 176°F the quantity of grease may be determined directly according to the bearing reference and operating speed from the table below. If the operating temperature is above 176°F a 25% pack of grease should be used regardless of operating speed (refer to the right-hand column of the table).

With a 'full pack' of grease the space within the housing (i.e. surrounding the bearing components) in the assembled unit is completely filled with grease.

The table assumes normal density grease (about 0.85 g/cm³).

Shaft Diameter (mm)	Bearing Reference	Speed (rpm) up to	Grease (full pack) (Kg)	Speed (rpm)		Grease (75% full pack) (Kg)	Speed (rpm)		Grease (50% full pack) (Kg)	Speed (rpm)		Grease (33% full pack) (Kg)	Speed (rpm) over	Grease (25% full pack) (Kg)
				from	to		from	to		from	to			
75	IDTB75M	667	0.19	667	1333	0.14	1333	2000	0.10	2000	2667	0.06	2667	0.05
80	IDTB80M	625	0.23	625	1250	0.17	1250	1875	0.12	1875	2500	0.08	2500	0.06
90	IDTB90M	556	0.25	556	1111	0.19	1111	1667	0.12	1667	2222	0.08	2222	0.06
100	IDTB100M	500	0.41	500	1000	0.31	1000	1500	0.20	1500	2000	0.13	2000	0.10
110	IDTB110M	455	0.44	455	909	0.33	909	1364	0.22	1364	1818	0.14	1818	0.11
120	IDTB120M	417	0.50	417	833	0.38	833	1250	0.25	1250	1667	0.17	1667	0.13
140	IDTB140M	357	0.65	357	714	0.48	714	1071	0.32	1071	1429	0.21	1429	0.16
160	IDTB160M	313	0.63	313	625	0.47	625	938	0.32	938	1250	0.21	1250	0.16
180	IDTB180M	278	0.77	278	556	0.58	556	833	0.39	833	1111	0.25	1111	0.19

ROUTINE GREASING

Relubricate the bearing weekly or every 150 hours of operation. Sizes up to and including 120mm: Use 2ml of fresh grease. Sizes over 120mm: Use 4ml of fresh grease. Note that 2ml is approximately 1 shot from a conventional side-lever grease gun. Automatic lubrication systems should be metered to deliver grease at an average rate equivalent to the routine greasing

periods and quantities specified. If it can be done safely, the bearing should be re-greased as it rotates to help distribute the grease. Do not mix different types of grease in the bearing. Excessive quantities of lubricant should not be used, particularly at high speeds, as this may result in excessive churning and overheating.

TIGHTENING TORQUES

The tightening torques for the assembly of the bearings and housing are given in the following table. All screws are metric

coarse thread, grade 12.9. Full assembly instructions are provided with each order, and are available separately if required.

Shaft Diameter (mm)	Bearing Reference	Clamping ring screw			Cartridge joint screw			Side screw			Pedestal joint screw			Flange joint screw		
		Screw size	Key size A/F (mm)	Torque (Nm)	Screw size	Key size A/F (mm)	Torque (Nm)	Screw size	Key size A/F (mm)	Torque (Nm)	Screw size	Key size A/F (mm)	Torque (Nm)	Screw size	Key size A/F (mm)	Torque (Nm)
75	IDTB75M	M5x25	4	8.5	M6x25	5	11	M6x10	3	7.8	M16x65	14	225	M12x55	10	90
80	IDTB80M	M5x25	4	8.5	M10x45	8	52.5	M6x10	3	7.8	M16x65	14	225	M16x65	14	225
90	IDTB90M	M5x25	4	8.5	M10x45	8	52.5	M6x10	3	7.8	M16x65	14	225	M16x65	14	225
100	IDTB100M	M8x30	6	35	M10x45	8	52.5	M6x10	3	7.8	M20x80	17	420	M16x65	14	225
110	IDTB110M	M8x30	6	35	M12x55	10	90	M6x10	3	7.8	M20x80	17	420	M20x80	17	420
120	IDTB120M	M8x30	6	35	M10x45	8	52.5	M6x10	3	7.8	M20x80	17	420	M20x80	17	420
140	IDTB140M	M8x30	6	35	M10x45	8	52.5	M6x10	3	7.8	M20x80	17	420	M20x80	17	420
160	IDTB160M	M8x30	6	35	M10x45	8	52.5	M10x16	5	30	M16x65	14	225	M20x100	17	420
180	IDTB180M	M8x30	6	35	M10x55	8	52.5	M10x16	5	30	M20x80	17	420	M24x100	19	712

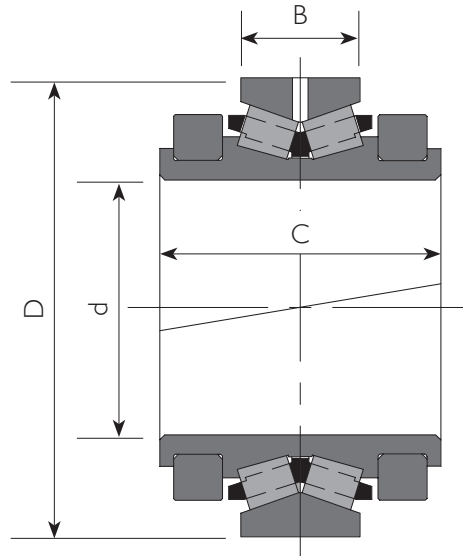

BEARING DATA

Shaft Diameter d (mm)	Reference	Bearing Ratings			Calculation Factors				Principal Dimensions			
		Cr (kN)	Cor (kN)	Max. Speed (rpm)	Y1	Y2	e	Yo	D (mm)	C (mm)	B (mm)	Mass (kg)
75	IDTB75M	143	208	3410	1.27	1.89	0.53	1.24	135	82.6	35	4.0
80	IDTB80M	152	232	3200	1.20	1.79	0.56	1.18	145	85	35	4.6
90	IDTB90M	160	254	2840	1.11	1.65	0.61	1.08	150	85	35	4.7
100	IDTB100M	235	379	2560	1.17	1.75	0.58	1.15	175	100	40	8.3
110	IDTB110M	282	504	2330	1.05	1.56	0.64	1.02	190	110	48	11.4
120	IDTB120M	295	544	2130	1.00	1.49	0.68	0.98	200	110	48	11.9
130	IDTB130M	296	555	1830	1.27	1.90	0.53	1.24	215	125	45	13.9
140	IDTB140M	296	555	1830	1.27	1.90	0.53	1.24	215	110	45	12.2
150	IDTB150M	350	670	1600	1.34	1.99	0.50	1.31	240	123.8	45	16.8
160	IDTB160M	350	670	1600	1.34	1.99	0.50	1.31	240	110	45	14.8
180	IDTB180M	358	716	1420	1.21	1.80	0.56	1.18	265	110	45	17.0

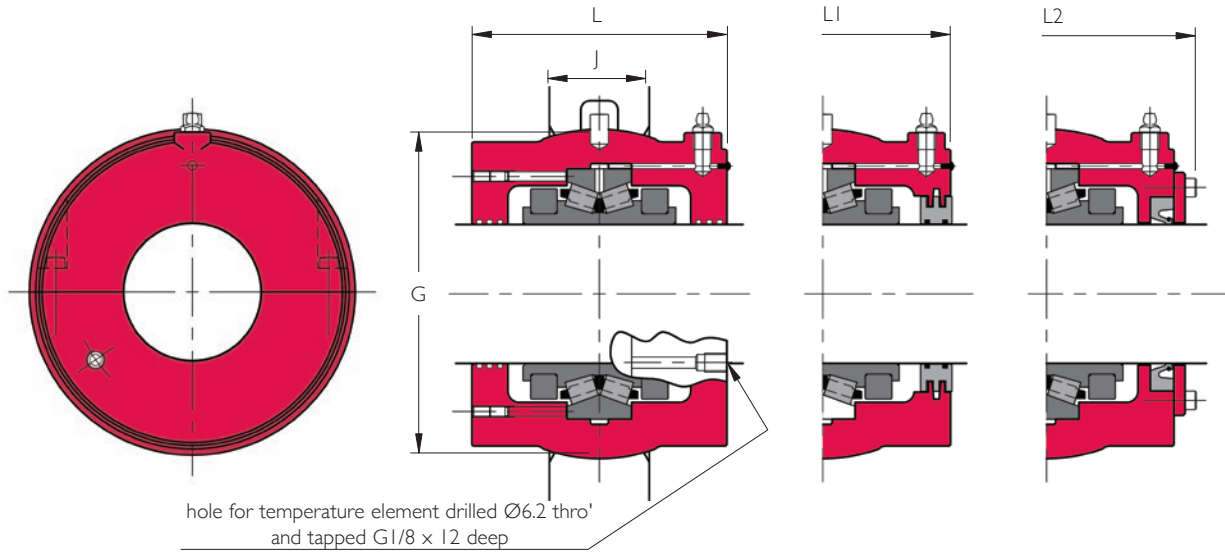

CARTRIDGE DATA

References		Principal Dimensions					Mass (kg)
Cartridge for LAB seals	Cartridge for ATL seals	G (mm)	J (mm)	L (mm)	L1 (mm)	L2 (mm)	
IDTC75GR75M	IDTC75GR30TL	177.80	50	138	140	162	11.8
IDTC80GR80M	IDTC80GR35TL	203.20	50	140	142	164	15.1
IDTC90GR90M	IDTC90GR35TL	203.20	50	146	148	170	13.5
IDTC100GR100M	IDTC100GR40TL	231.78	64	170	172	202	20.1
IDTC110GR110M	IDTC110GR45TL	266.70	76	178	180	210	29.8
IDTC120GR120M	IDTC120GR50TL	266.70	76	178	180	210	26.5
IDTC140GR130M	IDTC140GR50TL	279.40	76	190	192	222	31.2
IDTC140GR140M	IDTC140GR55TL	279.40	76	190	192	222	31.2
IDTC160GR150M	IDTC160GR60TL	311.15	76	200	202	232	47.0
IDTC160GR160M	IDTC160GR65TL	311.15	76	200	202	232	47.0
IDTC180GR180M	IDTC180GR70TL	336.55	95	200	206	232	42.5

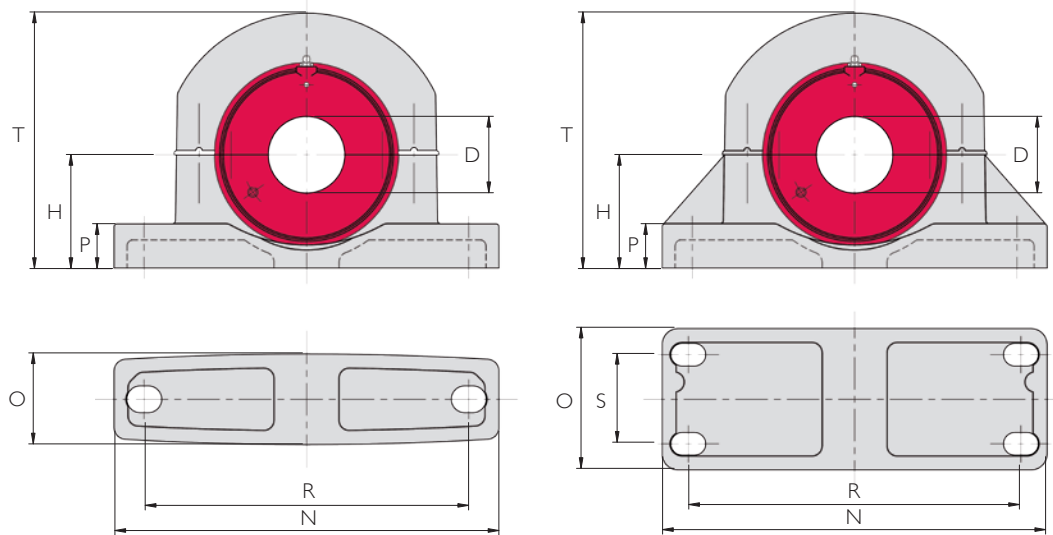

PEDESTAL DATA

Shaft Diameter d (mm)	Bearing Reference	Pedestal Reference	H (mm)	R		S (mm)	Bolts No.	Size	N (mm)	O (mm)	P (mm)	T (mm)	Mass (Pedestal only) (Kg)
				Min. (mm)	Max. (mm)								
75	IDTB75M	PN05	112	312	328	-	2	M24	380	90	44	252	13.3
80	IDTB80M	PN06	125	342	366	-	2	M24	420	102	52	272	14.7
90	IDTB90M	PN06	125	342	366	-	2	M24	420	102	52	272	14.7
100	IDTB100M	PN07	143	374	410	-	2	M24	466	120	60	314	20.6
110	IDTB110M	PN08	162	438	462	120	4	M24	508	178	38	372	43.3
120	IDTB120M	PN08	162	438	462	120	4	M24	508	178	38	372	43.3
130	IDTB130M	PN09	181	470	494	120	4	M24	558	178	41	405	52
140	IDTB140M	PN09	181	470	494	120	4	M24	558	178	41	405	52
150	IDTB150M	PN11	213	356	380	114	4	M24	508	178	32	430	53
160	IDTB160M	PN11	213	356	380	114	4	M24	508	178	32	430	53
180	IDTB180M	PN31	210	546	570	128	4	M24	636	204	50	470	83

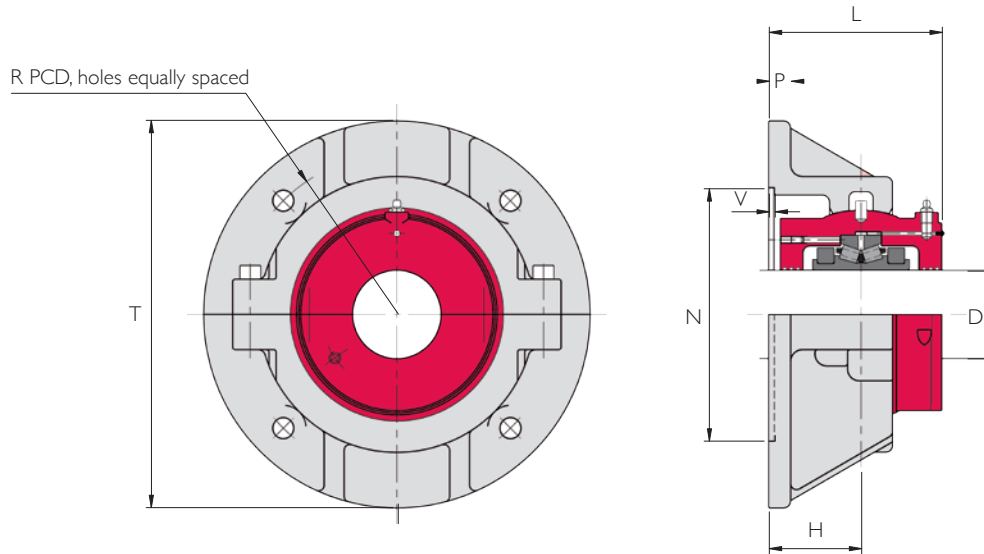

FLANGE DATA

Shaft Diameter d (mm)	Bearing Reference	Flange Reference	T(1) (mm)	Bolt Size	R (mm)	P (mm)	H (mm)	N(2) (mm)	V(2) (mm)	Mass (flange only) (kg)
75	IDTB75M	FN05	330	M16	274	19	79	215.90	3	19.4
80	IDTB80M	FN06	356	M16	302	19	86	244.48	3	22.0
90	IDTB90M	FN06	356	M16	302	19	86	244.48	3	22.0
100	IDTB100M	FN07	382	M16	334	22	92	276.23	3	26.6
110	IDTB110M	FN08	432	M24	374	22	98	314.33	3	34.9
120	IDTB120M	FN08	432	M24	374	22	98	314.33	3	34.9
130	IDTB130M	FN09	444	M24	384	25	98	317.50	3	40.8
140	IDTB140M	FN09	444	M24	384	25	98	317.50	3	40.8
150	IDTB150M	FN11	496	M24	426	25	105	352.43	3	58
160	IDTB160M	FN11	496	M24	426	25	105	352.43	3	58
180	IDTB180M	FN31	534	M24	466	25	124	393.70	3	81

1) Dimension shown is as-cast dimension. Depending upon manufacturing method used, flanges supplied may be machined 5mm smaller.

2) Dimensions shown are for locating spigot for mounting flange on to. Diameter tolerance of locating spigot: f8. Where SRSRP seals are used cartridge assembly may protrude into bulkhead. Consult Cooper for minimum bulkhead aperture size.

The following is a typical assembly sequence of a pillow block or flange mounted bearing and is included to allow engineers using this catalog to understand the assembly process of the Cooper bearing and to allow them to produce relevant documentation for their own machines, which may require this information. A full set of assembly instructions is usually packaged with each standard bearing, for use by the fitters. If non-standard bearings are to be used, and/or a different assembly sequence is required for the application, specific assembly instructions can be supplied on request.

The illustrations use a pillow block mounted unit as an example.

PRELIMINARY NOTES

Bearings must be disassembled before assembling into position.

Unwrap the bearing parts, remove the outer race halves (if supplied assembled around other parts), and separate the halves of the cage (if required). Various cage jointing methods are used depending on size and series of bearing. Undo the clamping ring screws and remove the clamping rings from the inner race.

Remove the preservative from all surfaces of all the parts.

All bearing and housing components (with the exception of pressed steel-, die cast- and plastic cages) are marked with matching numbers or letters on each half. Insure that the match marks on the halves are the same and are placed together on each component when the bearing is assembled.

Even though cage halves are not necessarily match-marked, they must not be mixed, as the rollers are graded into sets.

Complete roller bearings are interchangeable between similar Cooper cartridges. Individual parts should not be interchanged. Cartridges are interchangeable between standard outer housings provided that standard clearances are specified.

STEP 1 – HOUSING BASE

Place the pillow block base or flange lower half into position. If the precise location of the housing is predetermined it may be bolted into position. Generally, pillow block bases may require slight movement at a later stage in order to accurately position the shaft.

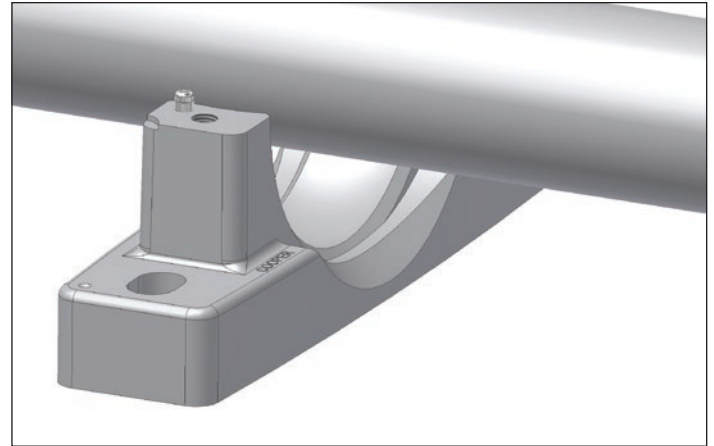

Note: The pillow block base is not shown in most of the illustrations that follow, for clarity of other details.

STEP 2 – INNER RACE

Lightly oil the shaft with thin machine oil, then remove the excess with a clean wiper. Place the inner race at the correct position on the cleaned shaft. Soft packing on the joint faces, or feeler gauges, should be used to insure that the joint gaps are approximately equal. Inner races of expansion bearings are usually set centrally with the outer race, but in cases of significant axial expansion there may be a deliberate offset. (This is usually up to a maximum of 10% of the roller length, but may be more in the case of special types of bearing).

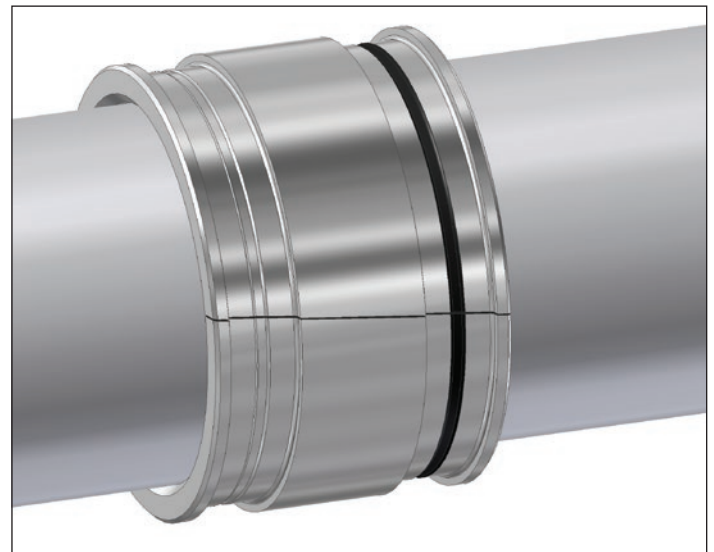

STEP 3 – CLAMPING RINGS

Fit the clamping rings with joints at approximately 90° to the inner race joints (45° in the case of large bearings with 4-part clamping rings). Progressively tighten all clamping ring screws.

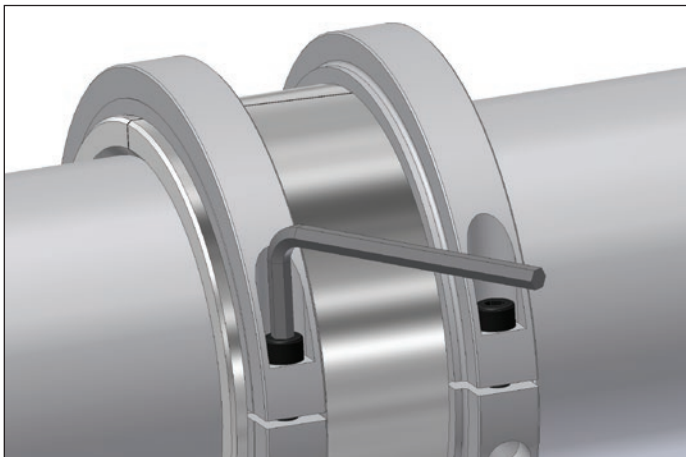

Tap down each half of the inner race and clamping rings all around the shaft using a soft-faced hammer, or insert a hardwood block between a steel hammer and the bearing parts. Retighten the clamping ring screws. Repeat until screws remain fully tight. Tightening torques are listed on pages 167 to 171.

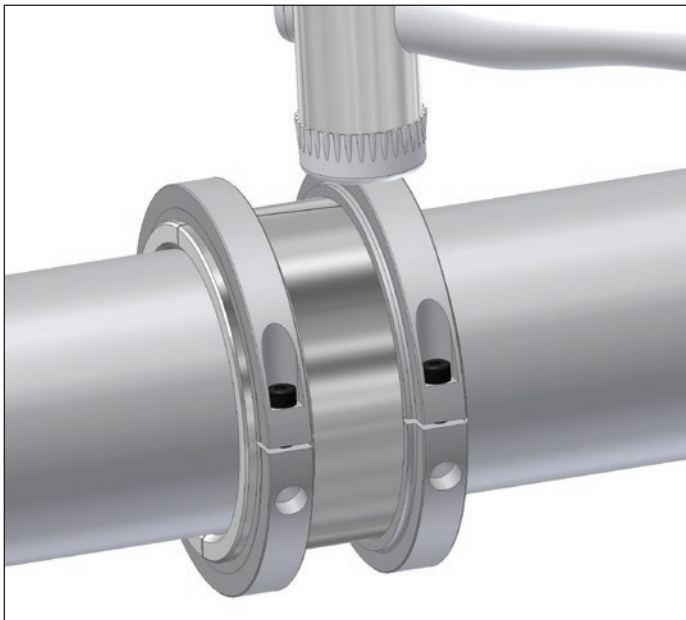

Check that there are approximately equal gaps at both joints of the inner race.

Check that there are approximately equal joints at both (or all 4) joints of each clamping ring.

STEP 4 – CAGE AND ROLLERS

Coat the bore of the cage and roller assembly with grease and lightly cover the inner race assembly (fitted to the shaft) all over with grease for protection.

Assemble the cage (complete with rollers) around the inner race. The two halves of the cage are fixed together by various means depending on size and series of bearing. (Further details are to be found in the assembly leaflets supplied with the bearing, or details of the joint of a particular size and series of cage can be supplied on request.)

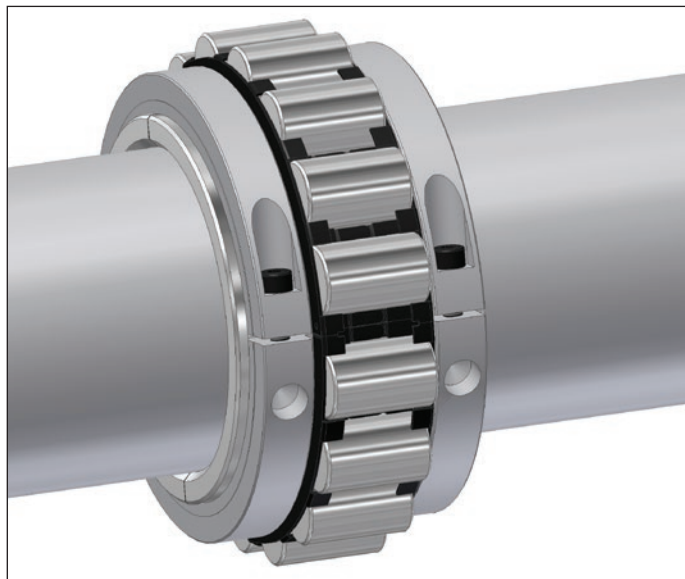

STEP 5 – CARTRIDGE AND OUTER RACE SUB-ASSEMBLY

Place the half outer race with the lubrication hole in the top half of the cartridge and the second half outer race into the lower half of the cartridge. Insure that the ends of the outer race project from the cartridge joint face by equal amounts.

All lipped outer races must be clamped axially. Side screws 'A' are fitted to all GR cartridges. Side rods 'B' are fitted to some sizes only.

Radial screws 'C' and washers are fitted to both EX and GR cartridges of larger sizes only.

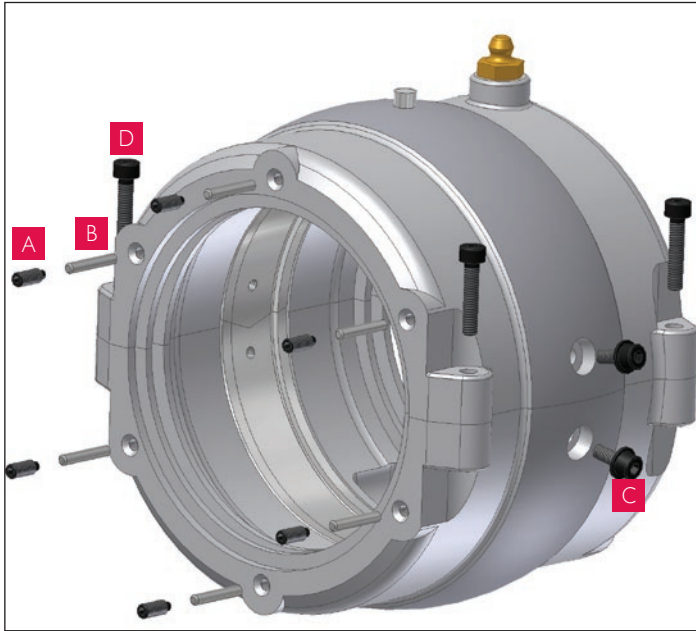

EX CARTRIDGES:

Just enter radial screws 'C' (where fitted, complete with washers) into the corresponding outer race holes, but do not tighten. Place the two half cartridges together, complete with half outer races, and fully tighten the joint screws 'D'. Fully tighten the radial screws 'C'.

CARTRIDGES FOR LIPPED OUTER RACES (GR AND SPECIAL TYPES):

Just enter radial screws 'C' (where fitted, complete with washers) into the corresponding outer race holes, but do not tighten. Place the two half cartridges together, complete with outer races, and fully tighten the joint screws 'D'. Enter the side rods 'B' (where fitted) and side screws 'A'. Progressively and fully tighten the side screws 'A' and radial screws 'C' (where fitted).

ALL TYPES:

Inject grease to fill the grease passages. Remove joint screws 'D' and separate cartridge halves, taking care that the outer race halves do not fall out of position in their respective half-cartridges.

STEP 6 – SEALS

If the unit is to be fitted with aluminum triple labyrinth (ATL) seals, fit them onto the shaft as follows:

Separate the ATL seal halves by driving out the two jointing pins. Lubricate the 'O' rings in the bore with grease. Reassemble on the shaft by compressing the 'O' rings of both halves sufficiently to allow the jointing pins to be reinserted, and reinsert the pins. Note: ATL seals are able to slide along the shaft once assembled.

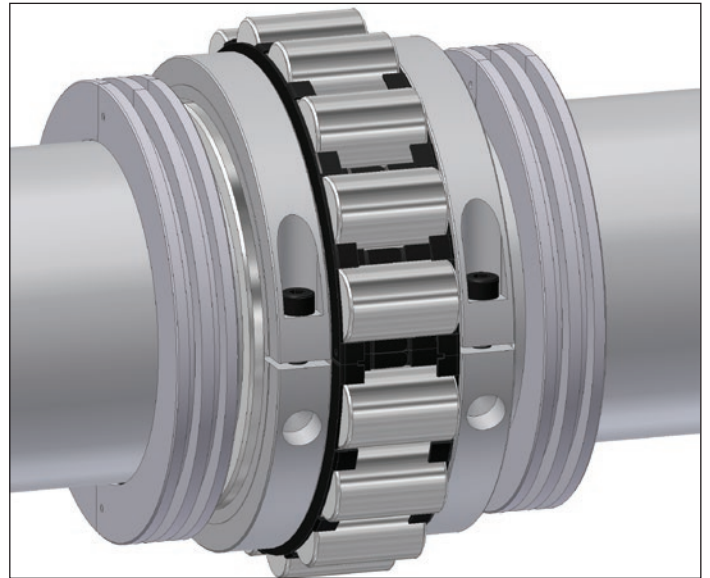

Felt seals should be soaked in oil before fitting into the cartridge end bores. Most types of seal other than triple labyrinth seals and SRSRP seals are fitted into the cartridge end bores before assembling the cartridge into position.

STEP 7 – LUBRICATION

Coat the inside of the cartridge, cage and rollers and all seals with grease (see page 172 to 176 for correct quantity). For speeds over 7,900 dn(in) (shaft diameter in inches multiplied by shaft speed in rpm) approximately 40% of the grease used should be applied to the bearing parts and the remainder applied to the inside of the cartridge. This is to avoid excessive churning of grease when running at high speed.

STEP 8 – CARTRIDGE

Lubricate the spherical seating of the bottom half of the cartridge with grease.

Place the bottom half of the cartridge on top of the bearing and rotate 180° into the pillow block base or half-flange.

Place the top half of the cartridge on top of the bottom half, close the cartridge and fully tighten the joint screws. Lubricate the spherical seating with grease.

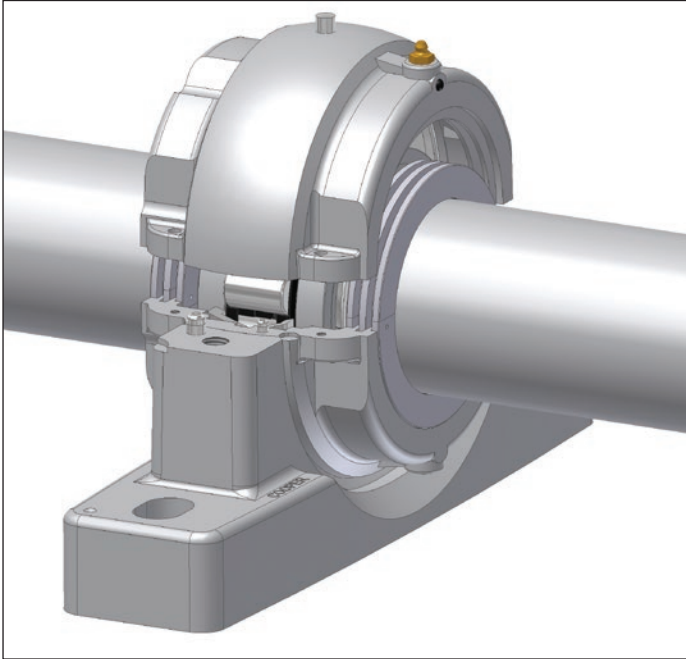

STEP 9 – HOUSING

If not already done, tighten the bolts fixing the pillow block base or lower flange half into position.

Place the pillow block cap or flange top half into position. If it is safe to do so, running the shaft for a time without the outer housing joint screws fully tightened will help the bearing to accurately align.

Fully tighten the joint screws.

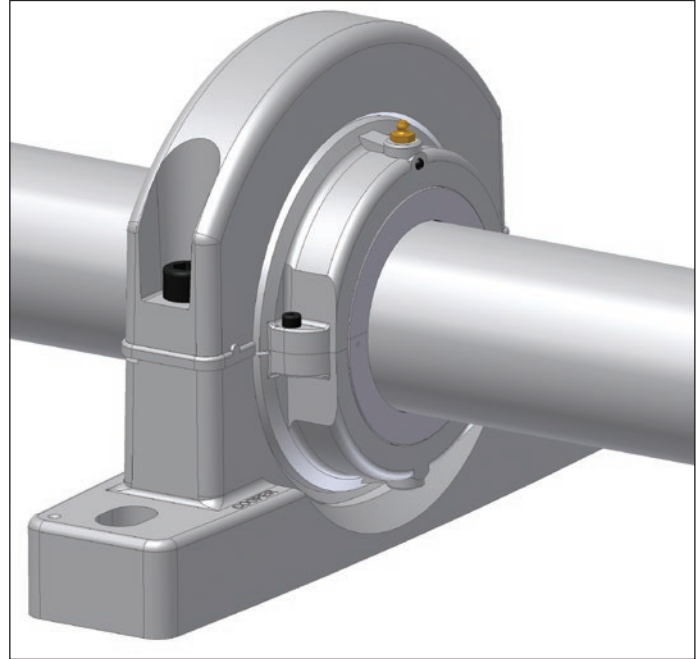

Shaft Diameter (in)	Bearing Reference	Clamping Ring Screw (1)			Cartridge Joint Screw (1)			Cartridge Radial Screw (1)			Side Screw (1)			Pillow Block Joint Screw (1)			Flange Joint Screw (1)		
		Screw Size	Key Size A/F (mm)	Torque(2) (lb ft)	Screw Size	Key Size A/F (mm)	Torque (lb ft)	Screw Size	Key Size A/F (mm)	Torque (lb ft)	Screw Size	Key Size A/F (mm)	Torque (lb ft)	Screw Size	Key Size A/F (mm)	Torque (lb ft)	Screw Size	Key Size A/F (mm)	Torque (lb ft)
1 3/16	01 B 103	M4x20	3	3.3	M4x25	3	2.6	-	-	-	M4x10	2	1.5	M8x45	6	19	M8x40	6	19
1 1/4	01 B 104	M4x20	3	3.3	M4x25	3	2.6	-	-	-	M4x10	2	1.5	M8x45	6	19	M8x40	6	19
1 7/16	01 B 107	M4x20	3	3.3	M4x25	3	2.6	-	-	-	M4x10	2	1.5	M8x45	6	19	M8x40	6	19
1 1/2	01 B 108	M4x20	3	3.3	M4x25	3	2.6	-	-	-	M4x10	2	1.5	M8x45	6	19	M8x40	6	19
1 11/16	01 E B 111	M4x20	3	3.3	M4x25	3	2.6	-	-	-	M4x10	2	1.5	M8x45	6	19	M8x40	6	19
1 3/4	01 E B 112	M4x20	3	3.3	M4x25	3	2.6	-	-	-	M4x10	2	1.5	M8x45	6	19	M8x40	6	19
1 15/16	01 E B 115	M4x20	3	3.3	M4x25	3	2.6	-	-	-	M4x10	2	1.5	M8x45	6	19	M8x40	6	19
	02 B 115	M5x25	4	6.3	M5x25	4	4.8	-	-	-	M4x10	2	1.5	M10x55	8	39	M10x45	8	39
2	01 E B 200	M4x20	3	3.3	M4x25	3	2.6	-	-	-	M4x10	2	1.5	M8x45	6	19	M8x40	6	19
	02 B 200	M5x25	4	6.3	M5x25	4	4.8	-	-	-	M4x10	2	1.5	M10x55	8	39	M10x45	8	39
2 3/16	01 E B 203	M4x20	3	3.3	M4x25	3	2.6	-	-	-	M4x10	2	1.5	M10x55	8	39	M10x45	8	39
	02 B 203	M5x25	4	6.3	M5x25	4	4.8	-	-	-	M4x10	2	1.5	M12x65	10	66	M12x55	10	66
2 1/4	01 E B 204	M4x20	3	3.3	M4x25	3	2.6	-	-	-	M4x10	2	1.5	M10x55	8	39	M10x45	8	39
	02 B 204	M5x25	4	6.3	M5x25	4	4.8	-	-	-	M4x10	2	1.5	M12x65	10	66	M12x55	10	66
2 7/16	01 E B 207	M4x20	3	3.3	M4x25	3	2.6	-	-	-	M4x10	2	1.5	M10x55	8	39	M10x45	8	39
	02 B 207	M5x25	4	6.3	M5x25	4	4.8	-	-	-	M4x10	2	1.5	M12x65	10	66	M12x55	10	66
2 1/2	01 E B 208	M4x20	3	3.3	M4x25	3	2.6	-	-	-	M4x10	2	1.5	M10x55	8	39	M10x45	8	39
	02 B 208	M5x25	4	6.3	M5x25	4	4.8	-	-	-	M4x10	2	1.5	M12x65	10	66	M12x55	10	66
2 11/16	01 E B 211	M4x20	3	3.3	M4x25	3	2.6	-	-	-	M4x10	2	1.5	M12x65	10	66	M12x55	10	66
	02 B 211	M6x25	5	11	M6x25	5	8.1	-	-	-	M4x10	2	1.5	M16x65	14	166	M12x55	10	66
2 3/4	01 E B 212	M4x20	3	3.3	M4x25	3	2.6	-	-	-	M4x10	2	1.5	M12x65	10	66	M12x55	10	66
	02 B 212	M6x25	5	11	M6x25	5	8.1	-	-	-	M4x10	2	1.5	M16x65	14	166	M12x55	10	66
2 15/16	100 B 215	M3x16	2.5	1.5	M4x25	3	2.6	-	-	-	M4x10	2	1.5	M10x55	8	39	M10x45	8	39
	01 E B 215	M4x20	3	3.3	M4x25	3	2.6	-	-	-	M4x10	2	1.5	M12x65	10	66	M12x55	10	66
	02 B 215	M6x25	5	11	M6x25	5	8.1	-	-	-	M4x10	2	1.5	M16x65	14	166	M12x55	10	66

1) All screws are metric coarse thread, grade 12.9

2) For vertical shaft or high thrust applications the clamping ring screw torque should be increased by up to 20%

Installation And Assembly - Screw Sizes, Wrench Sizes And Torques

Shaft Diameter (in)	Bearing Reference	Clamping Ring Screw (1)			Cartridge Joint Screw (1)			Cartridge Radial Screw (1)			Side Screw (1)			Pillow Block Joint Screw (1)			Flange Joint Screw (1)		
		Screw Size	Key Size A/F (mm)	Torque(2) (lb ft)	Screw Size	Key Size A/F (mm)	Torque (lb ft)	Screw Size	Key Size A/F (mm)	Torque (lb ft)	Screw Size	Key Size A/F (mm)	Torque (lb ft)	Screw Size	Key Size A/F (mm)	Torque (lb ft)	Screw Size	Key Size A/F (mm)	Torque (lb ft)
3	100 B 300	M3x16	2.5	1.5	M4x25	3	2.6	-	-	-	M4x10	2	1.5	M10x55	8	39	M10x45	8	39
	01E B 300	M4x20	3	3.3	M4x25	3	2.6	-	-	-	M4x10	2	1.5	M12x65	10	66	M12x55	10	66
	02 B 300	M6x25	5	11	M6x25	5	8.1	-	-	-	M4x10	2	1.5	M16x65	14	166	M12x55	10	66
3 3/16	01E B 303	M5x25	4	6.3	M5x25	4	4.8	-	-	-	M4x10	2	1.5	M16x65	14	166	M12x55	10	66
	02 B 303	M6x25	5	11	M6x25	5	8.1	-	-	-	M4x10	2	1.5	M16x65	14	166	M16x65	14	166
3 1/4	01E B 304	M5x25	4	6.3	M5x25	4	4.8	-	-	-	M4x10	2	1.5	M16x65	14	166	M12x55	10	66
	02 B 304	M6x25	5	11	M6x25	5	8.1	-	-	-	M4x10	2	1.5	M16x65	14	166	M16x65	14	166
3 7/16	100 B 307	M4x20	3	3.3	M4x25	3	2.6	-	-	-	M4x10	2	1.5	M12x65	10	66	M12x55	10	66
	01E B 307	M5x25	4	6.3	M5x25	4	4.8	-	-	-	M4x10	2	1.5	M16x65	14	166	M12x55	10	66
	02 B 307	M6x25	5	11	M6x25	5	8.1	-	-	-	M4x10	2	1.5	M16x65	14	166	M16x65	14	166
3 1/2	01E B 308	M5x25	4	6.3	M5x25	4	4.8	-	-	-	M4x10	2	1.5	M16x65	14	166	M12x55	10	66
	02 B 308	M6x25	5	11	M6x25	5	8.1	-	-	-	M4x10	2	1.5	M16x65	14	166	M16x65	14	166
3 3/4	01E B 312	M6x25	5	11	M6x25	5	8.1	-	-	-	M4x10	2	1.5	M16x65	14	166	M16x65	14	166
	02 B 312	M6x25	5	11	M6x25	5	8.1	-	-	-	M4x10	2	1.5	M20x80	17	310	M16x65	14	166
3 15/16	100 B 315	M4x20	3	3.3	M5x25	4	4.8	-	-	-	M4x10	2	1.5	M16x65	14	166	M12x55	10	66
	01E B 315	M6x25	5	11	M6x25	5	8.1	-	-	-	M4x10	2	1.5	M16x65	14	166	M16x65	14	166
	02 B 315	M6x25	5	11	M6x25	5	8.1	-	-	-	M4x10	2	1.5	M20x80	17	310	M16x65	14	166
	03 B 315	M10x45	8	52	M10x45	8	39	-	-	-	M6x10	3	5.8	M16x75	14	166	-	-	-
4	100 B 400	M4x20	3	3.3	M5x25	4	4.8	-	-	-	M4x10	2	1.5	M16x65	14	166	M12x55	10	66
	01E B 400	M6x25	5	11	M6x25	5	8.1	-	-	-	M4x10	2	1.5	M16x65	14	166	M16x65	14	166
	02 B 400	M6x25	5	11	M6x25	5	8.1	-	-	-	M4x10	2	1.5	M20x80	17	310	M16x65	14	166
	03 B 400	M10x45	8	52	M10x45	8	39	-	-	-	M6x10	3	5.8	M16x75	14	166	-	-	-
4 3/16	01 B 403	M6x25	5	11	M6x25	5	8.1	-	-	-	M6x10	3	5.8	M20x80	17	310	M16x65	14	166
	02 B 403	M8x30	6	26	M8x30	6	19	-	-	-	M6x10	3	5.8	M20x80	17	310	M20x80	17	310
4 7/16	100 B 407	M5x25	4	6.3	M6x25	5	8.1	-	-	-	M4x10	2	1.5	M16x65	14	166	M16x65	14	166
	01 B 407	M6x25	5	11	M6x25	5	8.1	-	-	-	M6x10	3	5.8	M20x80	17	310	M16x65	14	166
	02 B 407	M8x30	6	26	M8x30	6	19	-	-	-	M6x10	3	5.8	M20x80	17	310	M20x80	17	310
	03 B 407	M10x45	8	52	M10x45	8	39	M10x30	8	26	M6x10	3	5.8	M16x75	14	166	-	-	-
4 1/2	100 B 408	M5x25	4	6.3	M6x25	5	8.1	-	-	-	M4x10	2	1.5	M16x65	14	166	M16x65	14	166
	01 B 408	M6x25	5	11	M6x25	5	8.1	-	-	-	M6x10	3	5.8	M20x80	17	310	M16x65	14	166
	02 B 408	M8x30	6	26	M8x30	6	19	-	-	-	M6x10	3	5.8	M20x80	17	310	M20x80	17	310
	03 B 408	M10x45	8	52	M10x45	8	39	M10x30	8	26	M6x10	3	5.8	M16x75	14	166	-	-	-

1) All screws are metric coarse thread, grade 12.9

2) For vertical shaft or high thrust applications the clamping ring screw torque should be increased by up to 20%

Shaft Diameter (in)	Bearing Reference	Clamping Ring Screw (I)			Cartridge Joint Screw (I)			Cartridge Radial Screw (I)			Side Screw (I)			Pillow Block Joint Screw (I)			Flange Joint Screw (I)		
		Screw Size	Key Size A/F (mm)	Torque (lb ft)	Screw Size	Key Size A/F (mm)	Torque (lb ft)	Screw Size	Key Size A/F (mm)	Torque (lb ft)	Screw Size	Key Size A/F (mm)	Torque (lb ft)	Screw Size	Key Size A/F (mm)	Torque (lb ft)	Screw Size	Key Size A/F (mm)	Torque (lb ft)
4 15/16	100 B 415	M6x25	5	11	M6x25	5	8.1	-	-	-	M6x10	3	5.8	M20x80	17	310	M16x65	14	166
	01 B 415	M6x25	5	11	M6x25	5	8.1	-	-	-	M6x10	3	5.8	M20x80	17	310	M20x80	17	310
	02 B 415	M8x30	6	26	M8x30	6	19	-	-	-	M6x10	3	5.8	M20x100	17	310	M20x100	17	310
	03 B 415	M10x45	8	52	M10x45	8	39	M10x25	8	26	M10x16	5	22	M16x75	14	166	-	-	-
5	100 B 500	M6x25	5	11	M6x25	5	8.1	-	-	-	M6x10	3	5.8	M20x80	17	310	M16x65	14	166
	01 B 500	M6x25	5	11	M6x25	5	8.1	-	-	-	M6x10	3	5.8	M20x80	17	310	M20x80	17	310
	02 B 500	M8x30	6	26	M8x30	6	19	-	-	-	M6x10	3	5.8	M20x100	17	310	M20x100	17	310
	03 B 500	M10x45	8	52	M10x45	8	39	M10x25	8	26	M10x16	5	22	M16x75	14	166	-	-	-
5 3/16	01 B 503	M8x30	6	26	M8x30	6	19	-	-	-	M6x10	3	5.8	M20x80	17	310	M20x80	17	310
	02 B 503	M8x30	6	26	M8x30	6	19	-	-	-	M6x10	3	5.8	M20x100	17	310	M24x100	19	525
5 7/16	100 B 507	M6x25	5	11	M6x25	5	8.1	-	-	-	M6x10	3	5.8	M20x80	17	310	M20x80	17	310
	01 B 507	M8x30	6	26	M8x30	6	19	-	-	-	M6x10	3	5.8	M20x80	17	310	M20x80	17	310
	02 B 507	M8x30	6	26	M8x30	6	19	-	-	-	M6x10	3	5.8	M20x100	17	310	M24x100	19	525
	03 B 507	M10x45	8	52	M10x45	8	39	M10x25	8	26	M10x16	5	22	M20x100	17	310	-	-	-
5 1/2	100 B 508	M6x25	5	11	M6x25	5	8.1	-	-	-	M6x10	3	5.8	M20x80	17	310	M20x80	17	310
	01 B 508	M8x30	6	26	M8x30	6	19	-	-	-	M6x10	3	5.8	M20x80	17	310	M20x80	17	310
	02 B 508	M8x30	6	26	M8x30	6	19	-	-	-	M6x10	3	5.8	M20x100	17	310	M24x100	19	525
	03 B 508	M10x45	8	52	M10x45	8	39	M10x25	8	26	M10x16	5	22	M20x100	17	310	-	-	-
5 15/16	100 B 515	M6x25	5	11	M8x30	6	19	-	-	-	M6x10	3	5.8	M20x80	17	310	M20x80	17	310
	01 B 515	M8x30	6	26	M8x30	6	19	-	-	-	M6x10	3	5.8	M20x100	17	310	M20x100	17	310
	02 B 515	M8x30	6	26	M8x30	6	19	-	-	-	M6x10	3	5.8	M20x100	17	310	M24x100	19	525
	03 B 515	M10x45	8	52	M10x45	8	39	M10x30	8	26	M10x16	5	22	M20x100	17	310	-	-	-
6	100 B 600	M6x25	5	11	M8x30	6	19	-	-	-	M6x10	3	5.8	M20x80	17	310	M20x80	17	310
	01 B 600	M8x30	6	26	M8x30	6	19	-	-	-	M6x10	3	5.8	M20x100	17	310	M20x100	17	310
	02 B 600	M8x30	6	26	M8x30	6	19	-	-	-	M6x10	3	5.8	M20x100	17	310	M24x100	19	525
	03 B 600	M10x45	8	52	M10x45	8	39	M10x30	8	26	M10x16	5	22	M20x100	17	310	-	-	-
6 7/16	01E B 607	M8x30	6	26	M8x30	6	19	-	-	-	M6x10	3	5.8	M16x65	14	166	M20x100	17	310
	02E B 607	M10x45	8	52	M10x45	8	39	-	-	-	M6x10	3	5.8	M20x100	17	310	M24x100	19	525
	03 B 607	M12x55	10	89	M12x55	10	66	M12x35	10	44	M10x16	5	22	M20x100	17	310	-	-	-
6 1/2	01E B 608	M8x30	6	26	M8x30	6	19	-	-	-	M6x10	3	5.8	M16x65	14	166	M20x100	17	310
	02E B 608	M10x45	8	52	M10x45	8	39	-	-	-	M6x10	3	5.8	M20x100	17	310	M24x120	19	525
	03 B 608	M12x55	10	89	M12x55	10	66	M12x35	10	44	M10x16	5	22	M20x100	17	310	-	-	-
6 15/16	01E B 615	M8x30	6	26	M8x30	6	19	-	-	-	M6x10	3	5.8	M16x65	14	166	M20x100	17	310
	02E B 615	M10x45	8	52	M10x45	8	39	M10x25	8	26	M6x10	3	5.8	M20x100	17	310	M24x120	19	525
	03 B 615	M12x55	10	89	M12x55	10	66	M12x35	10	44	M10x16	5	22	M20x100	17	310	-	-	-

Installation And Assembly - Screw Sizes, Wrench Sizes And Torques

Shaft Diameter d (in)	Bearing Reference	Clamping Ring Screw (1)			Cartridge Joint Screw (1)			Cartridge Radial Screw (1)			Side Screw (1)			Pillow Block Joint Screw (1)			Flange Joint Screw (1)		
		Screw Size	Key Size A/F (mm)	Torque (lb ft)	Screw Size	Key Size A/F (mm)	Torque (lb ft)	Screw Size	Key Size A/F (mm)	Torque (lb ft)	Screw Size	Key Size A/F (mm)	Torque (lb ft)	Screw Size	Key Size A/F (mm)	Torque (lb ft)	Screw Size	Key Size A/F (mm)	Torque (lb ft)
7	01E B 700	M8x30	6	26	M8x30	6	19	-	-	-	M6x10	3	5.8	M16x65	14	166	M20x100	17	310
	02E B 700	M10x45	8	52	M10x45	8	39	M10x25	8	26	M6x10	3	5.8	M20x100	17	310	M24x120	19	525
	03 B 700	M12x55	10	89	M12x55	10	66	M12x35	10	44	M10x16	5	22	M20x100	17	310	-	-	-
7 15/16	01E B 715	M8x30	6	26	M8x30	6	19	M10x20	8	26	M6x10	3	5.8	M16x65	14	166	M24x100	19	525
	02E B 715	M12x55	10	89	M12x55	10	66	M10x30	8	26	M6x10	3	5.8	M20x100	17	310	M24x120	19	525
	03 B 715	M12x55	10	89	M12x55	10	66	M12x40	10	44	M10x16	5	22	M24x100	19	525	-	-	-
8	01E B 800	M8x30	6	26	M8x30	6	19	M10x20	8	26	M6x10	3	5.8	M16x65	14	166	M24x100	19	525
	02E B 800	M12x55	10	89	M12x55	10	66	M10x30	8	26	M6x10	3	5.8	M20x100	17	310	M24x120	19	525
	03 B 800	M12x55	10	89	M12x55	10	66	M12x40	10	44	M10x16	5	22	M24x100	19	525	-	-	-
9	01E B 900	M10x45	8	52	M10x45	8	39	M10x20	8	26	M6x10	3	5.8	M16x65	14	166	M24x100	19	525
	02E B 900	M12x55	10	89	M12x55	10	66	M10x30	8	26	M6x10	3	5.8	M20x100	17	310	M24x120	19	525
	03 B 900	M16x65	14	221	M16x75	14	166	M12x40	10	44	M10x16	5	22	M20x100	19	310	-	-	-
10	01E B 1000	M10x45	8	52	M10x45	8	39	M10x20	8	26	M6x10	3	5.8	M20x80	17	310	M24x100	19	525
	02E B 1000	M12x55	10	89	M12x55	10	66	M10x30	8	26	M6x10	5	22	M20x100	17	310	M24x100	19	525
	03 B 1000	M16x65	14	221	M16x75	14	166	M12x40	10	44	M10x16	5	22	M20x100	17	310	-	-	-
11	01E B 1100	M10x45	8	52	M10x45	8	39	M10x25	8	26	M10x16	5	22	M20x100	17	310	M24x120	19	525
	02E B 1100	M12x65	14	221	M16x75	14	166	M10x30	8	26	M10x16	5	22	M20x100	17	310	M24x100	19	525
	03X B 1100	M20x80	17	413	M20x100	17	310	M12x40	10	44	M10x16	5	22	M20x100	17	310	-	-	-
	03E B 1100	M20x80	17	413	M20x100	17	310	M12x35	10	44	M10x16	5	22	M20x100	17	310	-	-	-
12	01E B 1200	M10x45	8	52	M10x45	8	39	M10x25	8	26	M10x16	5	22	M20x100	17	310	M24x120	19	525
	02E B 1200	M12x65	14	221	M16x75	14	166	M10x30	8	26	M10x16	5	22	M20x100	17	310	M24x100	19	525
	03 B 1200	M20x80	17	413	M20x100	17	310	M12x55	10	44	M10x16	5	22	M20x100	17	310	-	-	-
13	01 B 1300	M12x55	10	89	M12x55	8	66	M10x25	8	26	M10x16	5	22	M20x100	17	310	M24x120	19	525
	02 B 1300	M16x65	14	221	M16x75	14	166	M10x30	8	26	M10x16	5	22	M20x100	17	310	M24x120	19	525
	03 B 1300	M20x80	17	413	M20x100	17	310	M12x55	10	44	M10x16	5	22	M24x100	19	525	-	-	-
14	01 B 1400	M12x55	10	89	M12x55	10	66	M10x25	8	26	M10x16	5	22	M20x100	17	310	M24x120	19	525
	02 B 1400	M16x65	14	221	M16x75	14	166	M12x30	10	44	M10x16	5	22	M20x100	17	310	-	-	-
	03E B 1400	M24x100	19	701	M20x100	17	310	M12x40	10	44	M16x25	8	92	M24x100	19	525	-	-	-
15	01 B 1500	M12x55	10	89	M12x55	10	66	M10x25	8	26	M10x16	5	22	M20x100	17	310	M24x100	19	525
	02 B 1500	M16x65	14	221	M16x75	14	166	M12x30	10	44	M10x16	5	22	M20x100	17	310	-	-	-
	03 B 1500	M24x100	19	701	M20x100	17	310	M12x55	10	44	M10x16	5	22	M24x120	19	525	-	-	-
16	01 B 1600	M12x55	10	89	M12x55	10	66	M10x25	8	26	M10x16	5	22	M20x100	17	310	M24x100	19	525
	02 B 1600	M16x65	14	221	M16x75	14	166	M12x35	10	44	M10x16	5	22	M20x100	17	310	-	-	-

1) All screws are metric coarse thread, grade 12.9

2) For vertical shaft or high thrust applications the clamping ring screw torque should be increased by up to 20%

Shaft Diameter (in)	Bearing Reference	Clamping Ring Screw (I)			Cartridge Joint Screw (I)			Cartridge Radial Screw (I)			Side Screw (I)			Pillow Block Joint Screw (I)			Flange Joint Screw (I)		
		Screw Size	Key Size A/F (mm)	Torque(2) (lb ft)	Screw Size	Key Size A/F (mm)	Torque (lb ft)	Screw Size	Key Size A/F (mm)	Torque (lb ft)	Screw Size	Key Size A/F (mm)	Torque (lb ft)	Screw Size	Key Size A/F (mm)	Torque (lb ft)	Screw Size	Key Size A/F (mm)	Torque (lb ft)
17	01 B 1700	M12x55	10	89	M12x55	10	66	M12x25	10	44	M10x16	5	22	M20x80	17	310	-	-	-
	02 B 1700	M16x65	14	221	M16x75	14	166	M12x35	10	44	M10x16	5	22	M20x100	17	310	-	-	-
	03E B 1700	M24x100	19	701	M20x100	17	310	M12x40	10	44	M16x25	8	92	M24x120	19	525	-	-	-
18	01 B 1800	M12x55	10	89	M12x55	10	66	M12x25	10	44	M10x16	5	22	M20x80	17	310	-	-	-
	02 B 1800	M16x65	14	221	M16x75	14	166	M12x35	10	44	M10x16	5	22	M20x100	17	310	-	-	-
	03E B 1800	M24x100	19	701	M20x100	17	310	M12x55	10	44	M16x25	8	92	M24x120	19	525	-	-	-
19	01 B 1900	M12x55	10	89	M12x55	10	66	M12x25	10	44	M10x16	5	22	M20x100	17	310	-	-	-
	02 B 1900	M20x80	17	413	M20x100	17	310	M12x35	10	44	M10x16	5	22	M24x120	19	525	-	-	-
20	01 B 2000	M16x65	14	221	M16x75	14	166	M12x30	10	44	M10x16	5	22	M20x100	17	310	-	-	-
	02 B 2000	M20x80	17	413	M20x100	17	310	M12x35	10	44	M10x16	5	22	M24x120	19	525	-	-	-
	03 B 2000	M24x100	19	701	M20x100	17	310	M16x65	14	111	M10x16	5	22	M24x120	19	525	-	-	-
21	01 B 2100	M16x65	14	221	M16x75	14	166	M12x30	10	44	M10x16	5	22	M20x100	17	310	-	-	-
	02 B 2100	M20x80	17	413	M20x100	17	310	M12x35	10	44	M10x16	5	22	M24x120	19	525	-	-	-
22	01 B 2200	M16x65	14	221	M16x75	14	166	M12x30	10	44	M10x16	5	22	M20x100	17	310	-	-	-
	02 B 2200	M20x80	17	413	M20x100	17	310	M12x35	10	44	M10x16	5	22	M24x120	19	525	-	-	-
	03E B 2200	M24x100	19	701	M20x100	17	310	M12x55	10	44	M16x25	8	92	M24x120	19	525	-	-	-
23	01 B 2300	M16x65	14	221	M16x75	14	166	M12x30	10	44	M10x16	5	22	M20x100	17	310	-	-	-
	02 B 2300	M20x80	17	413	M20x100	17	310	M12x35	10	44	M10x16	5	22	M24x120	19	525	-	-	-
	03E B 2300	M24x100	19	701	M20x100	17	310	M12x55	10	44	M16x25	8	92	M24x120	19	525	-	-	-
24	01 B 2400	M16x65	14	221	M16x75	14	166	M12x30	10	44	M10x16	5	22	M20x100	17	310	-	-	-
	02 B 2400	M20x80	17	413	M20x100	17	310	M12x35	10	44	M10x16	5	22	M24x120	19	525	-	-	-

GREASE QUANTITIES FOR INITIAL LUBRICATION

The quantity of grease required on initial assembly is dependent upon operating speed and temperature.

If the operating temperature is below 176°F the quantity of grease may be determined directly according to bearing reference and operating speed from the following table.

If the operating temperature is above 176°F, a 25% pack of grease

should be used regardless of speed (refer to the right hand column of the table).

With a 'full pack' of grease the space within the cartridge (i.e. surrounding the bearing components) in the assembled unit is completely filled with grease.

The table assumes normal density grease (about 0.49oz/in³).

Shaft Diameter (in)	Bearing Reference	Speed (rpm) up to	Grease (full pack)		Speed (rpm)		Grease (75% full pack)		Speed (rpm)		Grease (50% full pack)		Speed (rpm)		Grease (33% full pack)		Speed (rpm) over	Grease (25% full pack)	
			lb	oz	from	to	lb	oz	from	to	lb	oz	from	to	lb	oz		lb	oz
1 3/16	01 B 103	1312	0	2.1	1312	2625	0	1.6	2625	3937	0	1.1	3937	5249	0	0.7	5249	0	0.5
1 1/4	01 B 104	1312	0	2.1	1312	2625	0	1.6	2625	3937	0	1.1	3937	5249	0	0.7	5249	0	0.5
1 7/16	01 B 107	1312	0	2.1	1312	2625	0	1.6	2625	3937	0	1.1	3937	5249	0	0.7	5249	0	0.5
1 1/2	01 B 108	1312	0	2.1	1312	2625	0	1.6	2625	3937	0	1.1	3937	5249	0	0.7	5249	0	0.5
1 11/16	01E B 111	984	0	3.2	984	1969	0	2.4	1969	2953	0	1.6	2953	3937	0	1.0	3937	0	0.8
1 3/4	01E B 112	984	0	3.2	984	1969	0	2.4	1969	2953	0	1.6	2953	3937	0	1.0	3937	0	0.8
1 15/16	01E B 115	984	0	3.2	984	1969	0	2.4	1969	2953	0	1.6	2953	3937	0	1.0	3937	0	0.8
	02 B 115	984	0	5.3	984	1969	0	4.0	1969	2953	0	2.6	2953	3937	0	1.7	3937	0	1.3
2	01E B 200	984	0	3.2	984	1969	0	2.4	1969	2953	0	1.6	2953	3937	0	1.0	3937	0	0.8
	02 B 200	984	0	5.3	984	1969	0	4.0	1969	2953	0	2.6	2953	3937	0	1.7	3937	0	1.3
2 3/16	01E B 203	787	0	5.3	787	1575	0	4.0	1575	2362	0	2.6	2362	3150	0	1.7	3150	0	1.3
	02 B 203	787	0	7.4	787	1575	0	5.6	1575	2362	0	3.7	2362	3150	0	2.4	3150	0	1.9
2 1/4	01E B 204	787	0	5.3	787	1575	0	4.0	1575	2362	0	2.6	2362	3150	0	1.7	3150	0	1.3
	02 B 204	787	0	7.4	787	1575	0	5.6	1575	2362	0	3.7	2362	3150	0	2.4	3150	0	1.9
2 7/16	01E B 207	787	0	5.3	787	1575	0	4.0	1575	2362	0	2.6	2362	3150	0	1.7	3150	0	1.3
	02 B 207	787	0	7.4	787	1575	0	5.6	1575	2362	0	3.7	2362	3150	0	2.4	3150	0	1.9
2 1/2	01E B 208	787	0	5.3	787	1575	0	4.0	1575	2362	0	2.6	2362	3150	0	1.7	3150	0	1.3
	02 B 208	787	0	7.4	787	1575	0	5.6	1575	2362	0	3.7	2362	3150	0	2.4	3150	0	1.9
2 11/16	01E B 211	656	0	6.3	656	1312	0	4.8	1312	1969	0	3.2	1969	2625	0	2.1	2625	0	1.6
	02 B 211	656	0	10.6	656	1312	0	7.9	1312	1969	0	5.3	1969	2625	0	3.5	2625	0	2.6
2 3/4	01E B 212	656	0	6.3	656	1312	0	4.8	1312	1969	0	3.2	1969	2625	0	2.1	2625	0	1.6
	02 B 212	656	0	10.6	656	1312	0	7.9	1312	1969	0	5.3	1969	2625	0	3.5	2625	0	2.6
2 15/16	100 B 215	656	0	5.3	656	1312	0	4.0	1312	1969	0	2.6	1969	2625	0	1.7	2625	0	1.3
	01E B 215	656	0	6.3	656	1312	0	4.8	1312	1969	0	3.2	1969	2625	0	2.1	2625	0	1.6
	02 B 215	656	0	10.6	656	1312	0	7.9	1312	1969	0	5.3	1969	2625	0	3.5	2625	0	2.6

Shaft Diameter (in)	Bearing Reference	Speed (rpm) up to	Grease (full pack)		Speed (rpm)		Grease (75% full pack)		Speed (rpm)		Grease (50% full pack)		Speed (rpm)		Grease (33% full pack)		Speed (rpm) over	Grease (25% full pack)	
			lb	oz	from	to	lb	oz	from	to	lb	oz	from	to	lb	oz		lb	oz
3	100 B 300	656	0	5.3	656	1312	0	4.0	1312	1969	0	2.6	1969	2625	0	1.7	2625	0	1.3
	01E B 300	656	0	6.3	656	1312	0	4.8	1312	1969	0	3.2	1969	2625	0	2.1	2625	0	1.6
	02 B 300	656	0	10.6	656	1312	0	7.9	1312	1969	0	5.3	1969	2625	0	3.5	2625	0	2.6
3 3/16	01E B 303	562	0	10.6	562	1125	0	7.9	1125	1687	0	5.3	1687	2250	0	3.5	2250	0	2.6
	02 B 303	562	1	0	562	1125	0	11.9	1125	1687	0	7.9	1687	2250	0	5.2	2250	0	4.0
3 1/4	01E B 304	562	0	10.6	562	1125	0	7.9	1125	1687	0	5.3	1687	2250	0	3.5	2250	0	2.6
	02 B 304	562	1	0	562	1125	0	11.9	1125	1687	0	7.9	1687	2250	0	5.2	2250	0	4.0
3 7/16	100 B 307	573	0	7.8	573	1145	0	5.8	1145	1718	0	3.9	1718	2291	0	2.6	2291	0	1.9
	01E B 307	562	0	10.6	562	1125	0	7.9	1125	1687	0	5.3	1687	2250	0	3.5	2250	0	2.6
	02 B 307	562	1	0	562	1125	0	11.9	1125	1687	0	7.9	1687	2250	0	5.2	2250	0	4.0
3 1/2	01E B 308	562	0	10.6	562	1125	0	7.9	1125	1687	0	5.3	1687	2250	0	3.5	2250	0	2.6
	02 B 308	562	1	0	562	1125	0	11.9	1125	1687	0	7.9	1687	2250	0	5.2	2250	0	4.0
3 11/16	01E B 311	492	0	12.7	492	984	0	9.5	984	1476	0	6.3	1476	1969	0	4.2	1969	0	3.2
	02 B 311	492	1	5	492	984	1	0	984	1476	0	10.6	1476	1969	0	7.0	1969	0	5.3
3 3/4	01E B 312	492	0	12.7	492	984	0	9.5	984	1476	0	6.3	1476	1969	0	4.2	1969	0	3.2
	02 B 312	492	1	5	492	984	1	0	984	1476	0	10.6	1476	1969	0	7.0	1969	0	5.3
3 15/16	100 B 315	492	0	12.7	492	984	0	9.5	984	1476	0	6.3	1476	1969	0	4.2	1969	0	3.2
	01E B 315	492	0	12.7	492	984	0	9.5	984	1476	0	6.3	1476	1969	0	4.2	1969	0	3.2
	02 B 315	492	1	5	492	984	1	0	984	1476	0	10.6	1476	1969	0	7.0	1969	0	5.3
	03 B 315	492	2	10	492	984	2	0	984	1476	1	5	1476	1969	0	14.0	1969	0	10.6
4	100 B 400	492	0	12.7	492	984	0	9.5	984	1476	0	6.3	1476	1969	0	4.2	1969	0	3.2
	01E B 400	492	0	12.7	492	984	0	9.5	984	1476	0	6.3	1476	1969	0	4.2	1969	0	3.2
	02 B 400	492	1	5	492	984	1	0	984	1476	0	10.6	1476	1969	0	7.0	1969	0	5.3
	03 B 400	492	2	10	492	984	2	0	984	1476	1	5	1476	1969	0	14.0	1969	0	10.6
4 3/16	01 B 403	437	1	2	437	875	0	13.5	875	1312	0	9	1312	1750	0	5.9	1750	0	4.5
	02 B 403	437	2	0	437	875	1	8	875	1312	1	0	1312	1750	0	10.5	1750	0	7.9
4 7/16	100 B 407	437	0	13	437	875	0	9.5	875	1312	0	6.3	1312	1750	0	4.2	1750	0	3.2
	01 B 407	437	1	2	437	875	0	13.5	875	1312	0	9.0	1312	1750	0	5.9	1750	0	4.5
	02 B 407	437	2	0	437	875	1	8	875	1312	1	0	1312	1750	0	10.5	1750	0	7.9
	03 B 407	437	3	1	437	875	2	5	875	1312	1	9	1312	1750	1	0	1750	0	12.3
4 1/2	100 B 408	437	0	13	437	875	0	9.5	875	1312	0	6.3	1312	1750	0	4.2	1750	0	3.2
	01 B 408	437	1	2	437	875	0	13.5	875	1312	0	9.0	1312	1750	0	5.9	1750	0	4.5
	02 B 408	437	2	0	437	875	1	8	875	1312	1	0	1312	1750	0	10.5	1750	0	7.9
	03 B 408	437	3	1	437	875	2	5	875	1312	1	9	1312	1750	1	0	1750	0	12.3

Installation And Assembly - Grease Quantities For Initial Lubrication

Shaft Diameter (in)	Bearing Reference	Speed (rpm) up to	Grease (full pack)		Speed (rpm)		Grease (75% full pack)		Speed (rpm)		Grease (50% full pack)		Speed (rpm)		Grease (33% full pack)		Speed (rpm) over	Grease (25% full pack)	
			lb	oz	from	to	lb	oz	from	to	lb	oz	from	to	lb	oz		lb	oz
4 15/16	100 B 415	394	1	1	394	787	0	13.0	787	1181	0	9	1181	1575	0	5.7	1575	0	4.3
	01 B 415	394	1	5	394	787	1	0	787	1181	0	11	1181	1575	0	7.0	1575	0	5.3
	02 B 415	394	2	10	394	787	2	0	787	1181	1	5	1181	1575	0	14.0	1575	0	10.6
	03 B 415	437	3	1	437	875	3	5	875	1312	1	9	1312	1750	1	0	1750	0	12.3
5	100 B 500	394	1	1	394	787	0	13.0	787	1181	0	9	1181	1575	0	5.7	1575	0	4.3
	01 B 500	394	1	5	394	787	1	0	787	1181	0	11	1181	1575	0	7.0	1575	0	5.3
	02 B 500	394	2	10	394	787	2	0	787	1181	1	5	1181	1575	0	14.0	1575	0	10.6
	03 B 500	394	3	1	394	787	2	5	787	1181	1	9	1181	1575	1	0	1575	0	12.3
5 3/16	01 B 503	358	1	12	358	716	1	5	716	1074	0	14	1074	1432	0	9.1	1432	0	6.9
	02 B 503	358	3	1	358	716	2	5	716	1074	1	9	1074	1432	1	0	1432	0	12.3
5 7/16	100 B 507	358	1	7	358	716	1	1	716	1074	0	11	1074	1432	0	7.4	1432	0	5.6
	01 B 507	358	1	12	358	716	1	5	716	1074	0	14	1074	1432	0	9.1	1432	0	6.9
	02 B 507	358	3	1	358	716	2	5	716	1074	1	9	1074	1432	1	0	1432	0	12.3
	03 B 507	358	4	7	358	716	3	5	716	1074	2	3	1074	1432	1	7	1432	1	2
5 1/2	100 B 508	358	1	7	358	716	1	1	716	1074	0	11	1074	1432	0	7.4	1432	0	5.6
	01 B 508	358	1	12	358	716	1	5	716	1074	0	14	1074	1432	0	9.1	1432	0	6.9
	02 B 508	358	3	1	358	716	2	5	716	1074	1	9	1074	1432	1	0	1432	0	12.3
	03 B 508	358	4	7	358	716	3	5	716	1074	2	3	1074	1432	1	7	1432	1	2
5 15/16	100 B 515	328	2	4	328	656	1	11	656	984	1	2	984	1312	0	11.9	1312	0	9.0
	01 B 515	328	2	0	328	656	1	8	656	984	1	0	984	1312	0	10.5	1312	0	7.9
	02 B 515	328	3	1	328	656	2	5	656	984	1	9	984	1312	1	0	1312	0	12.3
	03 B 515	328	5	15	328	656	4	7	656	984	3	0	984	1312	1	15	1312	1	8
6	100 B 600	328	2	4	328	656	1	11	656	984	1	2	984	1312	0	11.9	1312	0	9.0
	01 B 600	328	2	0	328	656	1	8	656	984	1	0	984	1312	0	10.5	1312	0	7.9
	02 B 600	328	3	1	328	656	2	5	656	984	1	9	984	1312	1	0	1312	0	12.3
	03 B 600	328	5	15	328	656	4	7	656	984	3	0	984	1312	1	15	1312	1	8
6 7/16	01E B 607	303	2	3	303	606	1	11	606	909	1	2	909	1211	0	11.6	1211	0	8.8
	02E B 607	303	3	1	303	606	2	5	606	909	1	9	909	1211	1	0	1211	0	12.3
	03 B 607	303	7	15	303	606	5	15	606	909	4	0	909	1211	2	10	1211	2	0
6 1/2	01E B 608	303	2	3	303	606	1	11	606	909	1	2	909	1211	0	11.6	1211	0	8.8
	02E B 608	303	3	1	303	606	2	5	606	909	1	9	909	1211	1	0	1211	0	12.3
	03 B 608	303	7	15	303	606	5	15	606	909	4	0	909	1211	2	10	1211	2	0
6 15/16	01E B 615	281	2	10	281	562	2	0	562	844	1	5	844	1125	0	14.0	1125	0	10.6
	02E B 615	281	4	7	281	562	3	5	562	844	2	3	844	1125	1	7	1125	1	2
	03 B 615	281	9	4	281	562	6	15	562	844	4	10	844	1125	3	1	1125	2	5
7	01E B 700	281	2	10	281	562	2	0	562	844	1	5	844	1125	0	14.0	1125	0	10.6
	02E B 700	281	4	7	281	562	3	5	562	844	2	3	844	1125	1	7	1125	1	2
	03 B 700	281	9	4	281	562	6	15	562	844	4	10	844	1125	3	1	1125	2	5

Installation And Assembly - Grease Quantities For Initial Lubrication

Shaft Diameter (in)	Bearing Reference	Speed (rpm) up to	Grease (full pack)		Speed (rpm)		Grease (75% full pack)		Speed (rpm)		Grease (50% full pack)		Speed (rpm)		Grease (33% full pack)		Speed (rpm) over	Grease (25% full pack)	
			lb	oz	from	to	lb	oz	from	to	lb	oz	from	to	lb	oz		lb	oz
7 15/16	01E B 715	246	3	1	246	492	2	5	492	738	1	9	738	984	1	0	984	0	12.3
	02E B 715	246	5	15	246	492	4	7	492	738	3	0	738	984	1	15	984	1	8
	03 B 715	246	11	15	246	492	8	15	492	738	5	15	738	984	3	15	984	3	0
8	01E B 800	246	3	1	246	492	2	5	492	738	1	9	738	984	1	0	984	0	12
	02E B 800	246	5	15	246	492	4	7	492	738	3	0	738	984	1	15	984	1	8
	03 B 800	246	11	15	246	492	8	15	492	738	5	15	738	984	3	15	984	3	0
9	01E B 900	219	3	1	219	437	2	5	437	656	1	9	656	875	1	0	875	0	12
	02E B 900	219	7	15	219	437	5	15	437	656	4	0	656	875	2	10	875	2	0
	03 B 900	219	15	3	219	437	11	7	437	656	7	10	656	875	5	0	875	3	13
10	01E B 1000	197	4	7	197	394	3	5	394	591	2	3	591	787	1	7	787	1	2
	02E B 1000	197	9	4	197	394	6	15	394	591	4	10	591	787	3	1	787	2	5
	03 B 1000	197	17	14	197	394	13	6	394	591	8	15	591	787	5	14	787	4	7
11	01E B 1100	179	4	7	179	358	3	5	358	537	2	3	537	716	1	7	716	1	2
	02E B 1100	179	10	9	179	358	7	15	358	537	5	5	537	716	3	8	716	2	10
	03X B 1100	179	22	1	179	358	16	9	358	537	11	0	537	716	7	4	716	5	8
	03E B 1100	179	22	1	179	358	16	9	358	537	11	0	537	716	7	4	716	5	8
12	01E B 1200	164	4	7	164	328	3	5	328	492	2	3	492	656	1	7	656	1	2
	02E B 1200	164	11	15	164	328	8	15	328	492	5	15	492	656	3	15	656	3	0
	03 B 1200	164	24	4	164	328	18	3	328	492	12	2	492	656	8	0	656	6	1
13	01 B 1300	151	6	1	151	303	4	9	303	454	3	1	454	606	2	0	606	1	8
	02 B 1300	151	14	9	151	303	10	15	303	454	7	4	454	606	4	13	606	3	10
	03 B 1300	151	26	7	151	303	19	14	303	454	13	4	454	606	8	12	606	6	10
14	01 B 1400	141	6	10	141	281	4	15	281	422	3	5	422	562	2	3	562	1	11
	02 B 1400	141	15	14	141	281	11	15	281	422	7	15	422	562	5	4	562	4	0
	03E B 1400	141	33	1	141	281	24	13	281	422	16	9	422	562	10	15	562	8	4
15	01 B 1500	131	6	10	131	262	4	15	262	394	3	5	394	525	2	3	525	1	11
	02 B 1500	131	17	3	131	262	12	14	262	394	8	10	394	525	5	11	525	4	5
	03 B 1500	131	35	11	131	262	26	13	262	394	17	14	394	525	11	13	525	8	15
16	01 B 1600	123	7	15	123	246	5	15	246	369	4	0	369	492	2	10	492	2	0
	02 B 1600	123	19	14	123	246	14	14	246	369	9	15	369	492	6	9	492	4	15
17	01 B 1700	116	9	4	116	232	6	15	232	347	4	10	347	463	3	1	463	2	5
	02 B 1700	116	21	3	116	232	15	14	232	347	10	9	347	463	7	0	463	5	5
	03E B 1700	116	47	10	116	232	35	11	232	347	23	13	347	463	15	11	463	11	15
18	01 B 1800	109	9	4	109	219	6	15	219	328	4	10	328	437	3	1	437	2	5
	02 B 1800	109	21	3	109	219	15	14	219	328	10	9	328	437	7	0	437	5	5
	03E B 1800	109	54	4	109	219	40	11	219	328	27	2	328	437	17	14	437	13	9

Installation And Assembly - Grease Quantities For Initial Lubrication

Shaft Diameter (in)	Bearing Reference	Speed (rpm) up to	Grease (full pack)		Speed (rpm)		Grease (75% full pack)		Speed (rpm)		Grease (50% full pack)		Speed (rpm)		Grease (33% full pack)		Speed (rpm) over	Grease (25% full pack)	
			lb	oz	from	to	lb	oz	from	to	lb	oz	from	to	lb	oz		lb	oz
19	01 B 1900	104	10	9	104	207	7	15	207	311	5	5	311	414	3	8	414	2	10
	02 B 1900	104	22	8	104	207	16	14	207	311	11	4	311	414	7	7	414	5	10
20	01 B 2000	98	10	9	98	197	7	15	197	295	5	5	295	394	3	8	394	2	10
	02 B 2000	98	23	13	98	197	17	14	197	295	11	15	295	394	7	14	394	5	15
	03 B 2000	98	66	2	98	197	49	10	197	295	33	1	295	394	21	13	394	16	9
21	01 B 2100	94	11	15	94	187	8	15	187	281	5	15	281	375	3	15	375	3	0
	02 B 2100	94	25	2	94	187	18	14	187	281	12	9	281	375	8	5	375	6	5
22	01 B 2200	89	11	15	89	179	8	15	179	268	5	15	268	358	3	15	358	3	0
	02 B 2200	89	25	2	89	179	18	14	179	268	12	9	268	358	8	5	358	6	5
	03E B 2200	89	79	6	89	179	59	8	179	268	39	11	268	358	26	3	358	19	14
23	01 B 2300	86	13	4	86	171	9	15	171	257	6	10	257	342	4	6	342	3	5
	02 B 2300	86	27	12	86	171	20	13	171	257	13	14	257	342	9	3	342	6	15
	03E B 2300	86	84	11	86	171	63	8	171	257	42	5	257	342	27	15	342	21	3
24	01 B 2400	82	13	4	82	164	9	15	164	246	6	10	246	328	4	6	328	3	5
	02 B 2400	82	27	12	82	164	20	13	164	246	13	14	246	328	9	3	328	6	15

Routine greasing frequency depends on temperature, speed and environment. Grease quantities depend on bearing size. Excessive quantities of lubricant should not be used. Particularly at high speeds, this may result in excessive churning and overheating.

Automatic lubrication systems should be metered to deliver grease at an average rate equivalent to the routine greasing periods and quantities specified.

If it can be done safely, routine greasing should occur while the shaft is rotating to help distribute the grease. Do not mix different types of grease in the bearing.

The table below specifies routine greasing intervals. The shortest greasing interval should be selected to which one or more of the conditions in the table apply. If operating conditions fall outside those listed please contact our technical department for a recommended lubrication interval.

Routine greasing frequency	Operating conditions		
	Temperature	Speed dn (in)	Environment (3)
100 hours	176° to 347°F	8,000 to 12,000 (1)	very dirty/submerged
200 hours	140° to 176°F	4,000 to 8,000	dusty/splashed
400 hours (2)	Below 140°F	up to 4,000	clean/dry

The following table specifies the required quantity of grease at each routine greasing. Note that 1/16 oz. is approximately one shot from a conventional side-lever grease gun. Smaller quantities may be delivered using a push-type gun.

Shaft Dia. d	Bearing Reference	Routine Grease Quantity (oz)	Shaft Dia. d	Bearing Reference	Routine Grease Quantity (oz)
1 3/16	01 B 103	1/8	2 15/16	100 B 215	1/32*
1 1/4	1 B 104	1/8		01E B 215	1/8
				02 B 215	1/8
1 7/16	1 B 107	1/8	3	100 B 300	1/32*
1 1/2	1 B 108	1/8		01E B 300	1/8
			2 B 300	1/8	
1 11/16	01E B 111	1/8	3 3/16	01E B 303	1/8
1 3/4	01E B 112	1/8		02 B 303	1/8
			1 15/16	01E B 115	1/8
2	01E B 200	1/8	02 B 304	1/8	
			02 B 200	1/8	
2 3/16	01E B 203	1/8	3 7/16	100 B 307	1/32*
				02 B 203	1/8
2 1/4	01E B 204	1/8	3 1/2	2 B 307	1/8
				02 B 204	1/8
2 7/16	100 B 85M	1/8	3 11/16	02 B 308	1/8
				01E B 85M	1/8
2 1/2	01E B 90M	1/8	3 3/4	02 B 311	1/8
				02 B 90M	1/8
2 11/16	01E B 211	1/8	3 15/16	02 B 312	1/8
				02 B 211	1/8
2 3/4	01E B 212	1/8		02 B 315	1/8
				02 B 212	1/8

* May be increased to 1/16 oz. if speed is less than 4,000 dn (in), or up to 8,000 dn (in) if operating temperature is less than 176°F

$$dn \text{ (in)} = \text{bearing bore (in)} \times \text{shaft speed (rpm)}$$

- 1) Up to bearing maximum in case of 100 Series bearings
- 2) For EX bearings and GR bearings used for location only (i.e. no nominal thrust load) this may be extended to 1000 hours. For applications where temperature and operating speed allow for a full pack of grease this may be extended to one year for EX bearings and GR bearings used for location only.
- 3) For applications where operating speed and temperature allow for a full pack of grease, regreasing can occur every 400 hours regardless of the working environment.

Routine Greasing

Shaft Dia. d	Bearing Reference	Routine Grease Quantity (oz)	Shaft Dia. d	Bearing Reference	Routine Grease Quantity (oz)	Shaft Dia. d	Bearing Reference	Routine Grease Quantity (oz)	Shaft Dia. d	Bearing Reference	Routine Grease Quantity (oz)
4	100 B 400	1/16	5 1/2	100 B 508	1/8	9	01E B 900	1/8	16	01 B 1600	1/2
	01E B 400	1/8		01 B 508	1/8		02E B 900	1/4		02 B 1600	1/2
	02 B 400	1/8		02 B 508	1/8		03 B 900	1/2			
	03 B 400	1/8		03 B 508	1/4						
4 3/16	02 B 403	1/8	5 15/16	100 B 515	1/8	10	01E B 1000	1/8	17	01 B 1700	1/2
	03 B 403	1/8		01 B 515	1/8		02E B 1000	1/4		02 B 1700	1/2
				02 B 515	1/8		03 B 1000	1/2		03E B 1700	3/4
				03 B 515	1/4						
4 7/16	100 B 407	1/16	6	100 B 600	1/8	11	01E B 1100	1/4	18	01 B 1800	1/2
	01 B 407	1/8		01 B 600	1/8		02E B 1100	1/2		02 B 1800	3/4
	02 B 407	1/8		02 B 600	1/8		03X B 1100	1/2		03E B 1800	1
	03 B 407	1/8		03 B 600	1/4		03E B 1100	1/2			
4 1/2	100 B 408	1/16	6 7/16	01E B 607	1/8	12	01E B 1200	1/4	19	01 B 1900	1/2
	01 B 408	1/8		02E B 607	1/4		02E B 1200	1/2		02 B 1900	3/4
	02 B 408	1/8		03 B 607	1/4		03 B 1200	1/2			
	03 B 408	1/8									
4 15/16	100 B 415	1/8	6 1/2	01E B 608	1/8	13	01 B 1300	1/4	20	01 B 2000	1/2
	01 B 415	1/8		02E B 608	1/4		02 B 1300	1/2		02 B 2000	3/4
	02 B 415	1/8		03 B 608	1/4		03 B 1300	3/4		03 B 2000	1
	03 B 415	1/8									
5	100 B 500	1/8	6 15/16	01E B 615	1/8	14	01 B 1400	1/4	21	01 B 2100	1/2
	01 B 500	1/8		02E B 615	1/4		02 B 1400	1/2		02 B 2100	3/4
	02 B 500	1/8		03 B 615	1/4		03E B 1400	3/4			
	03 B 500	1/8									
5 3/16	01 B 503	1/8	7	01E B 700	1/8	15	01 B 1500	1/4	22	01 B 2200	1/2
	02 B 503	1/8		02E B 700	1/4		02 B 1500	1/2		02 B 2200	3/4
				03 B 700	1/4		03 B 1500	3/4		03E B 2200	1
5 7/16	100 B 507	1/8	7 15/16	01E B 715	1/8	23	01 B 2300	1/2	23	01 B 2300	1/2
	01 B 507	1/8		02E B 715	1/4		02 B 2300	3/4		02 B 2300	3/4
	02 B 507	1/8		03 B 715	1/2		03E B 2300	1		03E B 2300	1
	03 B 507	1/4									
			8	01E B 800	1/8	24	01 B 2400	1/2	24	01 B 2400	1/2
		02E B 800		1/4	02 B 2400		3/4	02 B 2400		3/4	
		03 B 800		1/2							

When a bearing reaches the end of its working life, it doesn't have to be discarded without providing further value. Three options for dealing with end-of-life bearings are outlined below.

RECONDITIONING

Cooper offers a reconditioning service for larger bearings. A used bearing is thoroughly cleaned and a detailed report prepared on its condition and the required work required to bring it back to an as-new functional condition. Generally a reconditioned bearing will consist of a combination of remachined components of the original bearing and new components to give the correct clearances.

Reconditioning is generally more economical than manufacture of new bearings, depending upon the amount of work required to the subject bearing, for the following bearings:

- 01 Series:** 13"/320mm bore size and over
- 02 Series:** 13"/320mm bore size and over
- 03 Series:** 6 1/2"/160mm bore size and over
- 04 Series:** all sizes
- Thrust bearings:** all sizes

Cooper is also able to recondition radial and thrust cylindrical bearings of non-Cooper manufacture.

FAILURE ANALYSIS

Cooper offers a failure analysis service for all sizes of bearing, of any age. Where appropriate, we will offer advice on fitting practices, lubrication regime, or modifications to the mounting arrangements to help improve future bearing life.

Bearings sent for analysis may be reconditioned, recycled or returned as appropriate.

Please inform Cooper if you wish to use this service, before returning bearings to one of our sites. A small charge may be made depending on requirements.

RECYCLING

The materials used in a Cooper bearing unit are almost completely recyclable. The diagram below helps to identify the various materials used in standard and popular optional versions of Cooper bearings so that they can be segregated as required.

OUTER HOUSING

Gray iron or ductile iron as standard.
 Cast steel housings will usually have the letter 'S' inserted into their reference compared to the standard units listed in this catalog (e.g. "PS07" instead of "P07" or "FS07" instead of "F07").
 Fabricated housings are usually mild steel

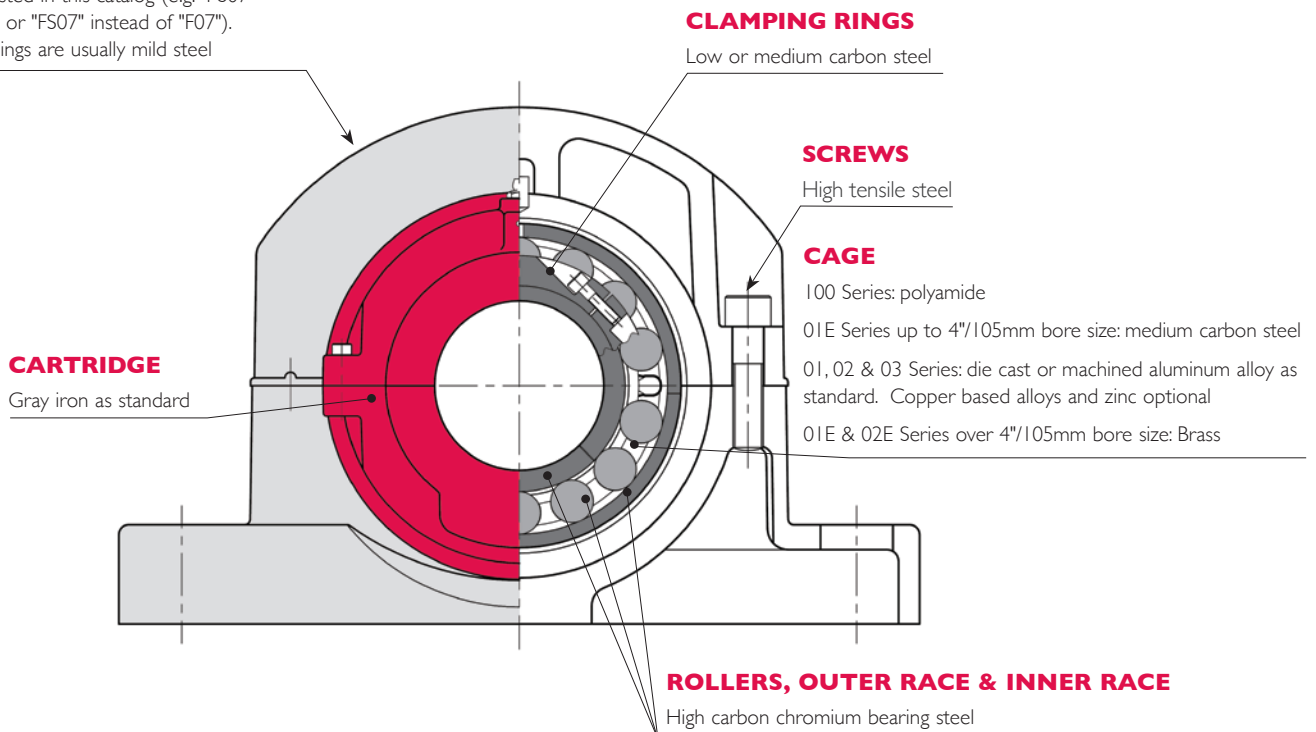

PROBLEM: OVERHEATING

Possible Cause	Solution
Shaft oversize. Bearing running tight.	Provide shaft with correct tolerance. Contact Cooper technical department.
Aluminum triple labyrinth seal rubbing.	Seal bore and labyrinth should be greased during installation.
Housing overpacked with grease or oil level too high.	Bearing will purge excess grease through seals. Oil lubrication - reduce level to just below cage.
Wrong type of grease or oil causing lubricant breakdown.	Consult reliable lubricant manufacturer for proper type of lubricant or contact Cooper technical department.
Low oil level. Insufficient grease.	Oil level should be just below cage outside diameter. Add proper grease.
Inner race rubbing against seals.	Check clamping ring screws to make sure inner race is tight on the shaft. Make sure the expansion bearing is mounted properly with rollers positioned centrally on outer race.
Incorrect shaft alignment.	Recheck alignment.
Bearing selected with inadequate internal clearance for high temperature operation.	Contact Cooper technical department.
Oil lubrication hole blocked. Grease passage blocked.	Inspect and clean holes. Refill to proper level.
Two fixed bearings on common shaft.	Remove one bearing and replace with an expansion bearing.
Pinching of bearing.	Make sure entire area of pillow block base is supported.
Bearing cartridge not aligned.	Lubricate cartridge spherical with anti-seize compound. With pillow block cap in place and cap bolts loose, rotate or run shaft a few revolutions while under load. Re-tighten cap bolts.

PROBLEM: NOISY BEARING

Possible Cause	Solution
Foreign matter or corrosive agent entering bearing.	Remove and inspect bearing and seals. Clean and re-lubricate bearing and seals.
Pinching of bearing.	Make sure entire area of pillow block base is supported.
Undersize shaft.	Measure shaft for proper fit. Refer to page 20.
Inner race rubbing against seals.	Check clamping ring screws to make sure the inner race is tight on shaft. Make sure the expansion bearing is mounted correctly with roller positioned centrally on the outer race.
Improper mounting of bearing.	Inspect bearing. Check that all match marks coincide. If parts are damaged, replace with new bearing.
Aluminum triple labyrinth seal rubbing.	Seal bore and labyrinth should be greased during installation.
Low oil level. Insufficient grease.	Oil levels should be just below cage outside diameter. Add correct grease.

PROBLEM: NOISY BEARING (CONTINUED)

Possible Cause	Solution
Wrong type of grease or oil causing lubricant breakdown.	See lubrication section or contact Cooper technical department.
Bearing selected with incorrect internal clearance.	Contact Cooper technical department.
Shaft does not contain a fixed bearing.	Remove one expansion bearing and replace with fixed bearing.
Two fixed bearings on common shaft.	Remove one and replace with an expansion bearing.
Unbalanced load.	Re-balance machine.
Bearing exposed to vibration while machine is idle.	Examine bearing for brinelling separated by the distance equal to spacing of rollers. Replace bearing. Rotate shaft at least once every two weeks to prevent brinelling.

PROBLEM: VIBRATION

Possible Cause	Solution
Foreign matter or corrosive agent entering bearing.	Remove and inspect bearing and seals. Clean and re-lubricate bearing and seals.
Pinching of bearing.	Make sure the entire area of the pillow block base is supported.
Shaft undersize.	Measure shaft for proper fit. Refer to page 20.
Unbalanced load.	Re-balance machine.
Flat on roller due to skidding.	Replace bearing. Consult Cooper technical department if problem persists.
Improper mounting of bearing.	Inspect bearing. Check that all match marks coincide. If parts are damaged, replace with new bearing.
Bearing cartridge not aligned.	Lubricate cartridge spherical with anti-seize compound. With pillow block cap in place and cap bolts loose, rotate or run shaft a few revolutions while under load. Re-tighten cap bolts.
Excessive clearance in bearing resulting in vibration.	Use bearing with recommended internal clearance.
Failure to clean bearing before assembly.	Remove and carefully clean bearing and re-assemble with correct lubrication.

PROBLEM: BEARING LOOSE ON SHAFT

Possible Cause	Solution
Clamping rings not tightened sufficiently.	Make sure clamping rings are fully tightened. Refer to assembly procedure.
Undersize shaft.	Measure shaft for proper fit. Refer to page 20.
Shaft out of round or not parallel.	Measure shaft. Refer to page 20.

WHO TO CONTACT

With offices worldwide we have dedicated teams of specialists, sales managers and engineers with vast experience of industry requirements at your fingertips, wherever you are. Please see the back cover for the nearest office to you.

If you are situated in a country or areas where we don't yet have an office, then contact one of our many Cooper

authorized distribution partners, acting in your area on our behalf. For a complete list of distributors, please contact us or visit our website at www.CooperBearings.com.

There will always be someone available to answer your questions or point you in the right direction, so whatever your requirements don't hesitate to get in touch.

COMPATIBILITY OF BEARINGS AND HOUSINGS

There are 4 main sub-assemblies to a typical complete Cooper bearing unit:

BEARING

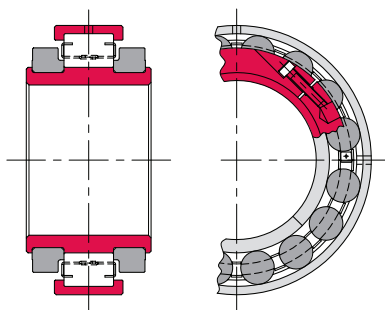

OUTER HOUSING

Pillow block

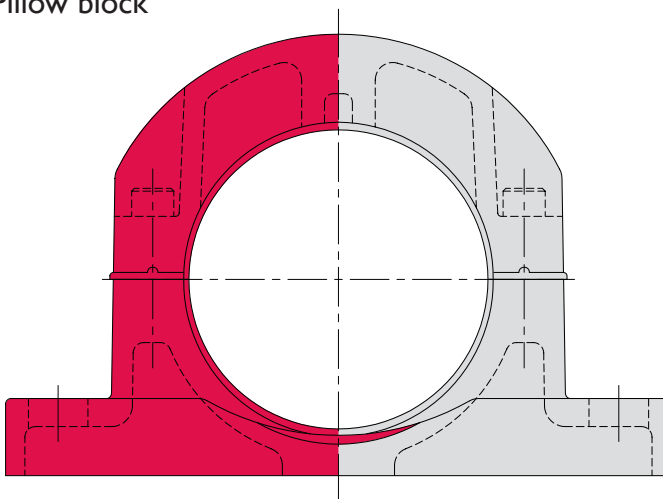

CARTRIDGE

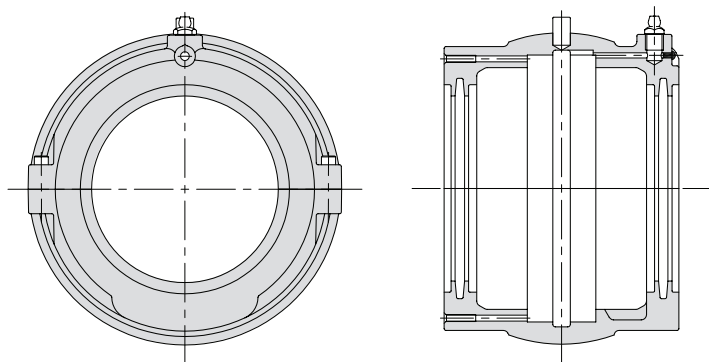

Flange

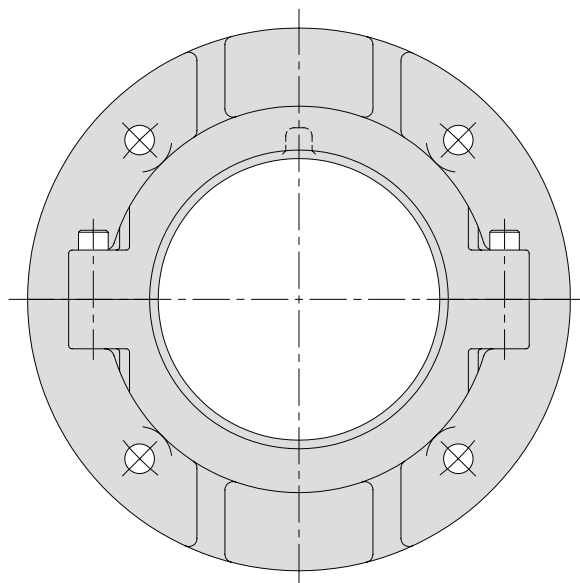

SEAL (ALT SHOWN)

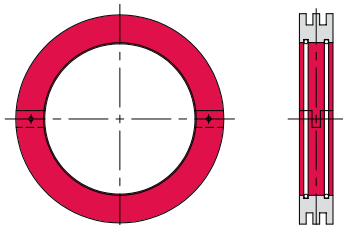

Generally, sub-assemblies are interchangeable and may be ordered separately using the part codes listed in the relevant sections of this catalog.

Individual components, such as a single race, are not generally supplied as they are not interchangeable between sub-assemblies.

Compatible bearing, cartridge and standard pillow block combinations are listed together in the relevant section. For other types of outer housing the reference of the compatible bearing is listed with the housing data, and the relevant cartridge part code (and further details of the bearing) can be found by reference to the bearings, cartridges and pillow blocks sections.

Cartridges and outer housings with matched diameters for reduced clearance are sometimes supplied, in which case the cartridge and outer housing cannot be replaced individually. Rod-end type housings have this feature as standard, and a matched cartridge is supplied with the outer housing.

Hanger units do not require a separate cartridge.

SIZE REFERENCES

Part codes for cartridges with TL seal grooves contain a reference to the series of bearing the cartridge is intended to house, plus a reference to the size of housing the cartridge can be fitted in, e.g.:

100 C 05

This is for 100 Series bearings and can be fitted in a P05 pillow block, F05 flange or other housing with similar spherical bore. It is possible to fit more than one bore size of bearing in this cartridge, but different seals will be fitted according to bore size.

Part codes for bearings and cartridges with single seal grooves contain a reference to the bore size, e.g. (highlighted):

01 C **65M** EX

01 B **207** EX

Bore size references ending in 'M' indicate metric bores, with the preceding number the bore size in millimeters (e.g. '65M' indicates a 65mm bore, '200M' indicates a 200mm bore).

Bore sizes not ending in 'M' indicate inch-size bores. The last two digits indicate sixteenths of an inch, with the preceding digit(s) indicating whole inches. Some examples of inch-size bore references are as follows:

Reference	Bore size
207	2 7/16"
415	4 15/16"
1008	10 1/2"
2000	20"

Some bearings and cartridges have a hyphenated bore size reference, e.g.:

01 B **600-160M** EX

In this case the part of the reference after the hyphen indicates the bore, using the format explained above. The part of the reference before the hyphen is used to distinguish the bearing from other bearings in the same series (in this case 01 Series) having the same bore size but different dimensions otherwise.

Note: Bore size reference marking on bearings

When determining the bore size of an existing bearing only the size reference on the inner race should be used to indicate actual bore size. Outer races, clamping rings and cage and roller assemblies are common to bearings of several bore sizes and may have a 'group' size reference that differs from the bore size of the inner race.

BEARING TYPES

The main configurations of bearing are explained on page 4.

SPECIAL FEATURES

Suffix characters may be used to indicate special features.

Examples include:

BEARING FEATURES

C2/C3/C5	Special clearances as explained on page 10.
AF	Axial float. This is preceded by the amount of axial float, e.g.: 2mm AF.
AL(D)F	Aluminum cage with (double) flange (usually race riding).
AP	Air/grease purge points.
CHAM	Special chamfer to inner race bore. This is followed by size of chamfer, e.g. (to indicate 7mm x 45° chamfer): CHAM 7.
EXILOG	Bearing with fixed type outer race and floating inner race (see page 6).
FR	Full complement of rollers (no cage).
GM	Gunmetal / brass / bronze cage.
GM(D)F	Gunmetal / brass / bronze cage with (double) flange (usually race riding).
GROSL	Single lipped outer race (see page 5).
OSO	Outer race set out (particularly for large bearings where outer race is usually retained in housing by radial screws).
XJR	Joint relief (to allow inner race to be mounted in recess).
ZN	Zinc alloy cage.

CARTRIDGE FEATURES

BOBP	Bolt-on blanking plate.
BOBT	Bolt-on blanking plate with thrust bearing.
BP/BT/BPTL/BTTL	See page 28.
IH	Inspection hole (for measuring position of inner race of expansion bearings once assembled).
OB	Overbore (cartridge end bore is larger than bearing bore). This is followed by end bore size, using same format as bearing bore reference, e.g.: OB 207 or O.B 65M (or OB 65mm).
TE	Drilled for temperature indicator element.
OIL LUB	Oil lubricated.

References to special seal types (some of which require special cartridges) can be found on page 26.

A letter may succeed the 'C' in the cartridge designation to indicate that the cartridge is made from non-standard material. taking the examples of 01 C 60M and 01 C 03 as examples:

01 CN 60M and 01 CN 03 would indicate nodular (ductile) iron.

01 CS 60M and 01 CS 03 would indicate steel.

01 CA 60M and 01 CA 03 would indicate aluminum.

OUTER HOUSING FEATURES

BEM Base ends machined. This may be followed by machined length, e.g.: BEM 500mm.

SI Reduced swivel clearance between outer housing and cartridge.

SLUB Lubrication to spherical seat.

For outer housings made in material other than standard, letters are interposed between the letter(s) designating the housing type (e.g. 'P' for pillow block, 'F' for flange or 'RET' for rod-end T-type) and the size designation. Taking the example of a P06 pillow block:

PN06 indicates a P06 in nodular (ductile) iron

PS06 indicates a P06 in steel

PA06 indicates a P06 in aluminum

Ductile iron and steel versions of an RET06 would be designated RETN06 and RETS06 respectively.

Numbers may be suffixed to bearing, cartridge or outer housing designations indicating a combination of special features or parts to special dimensions.

CUSTOMER SERVICE CENTERS



Scan for more info about our products

COOPER BEARINGS GROUP

USA, Canada, Mexico and Central America

The Cooper Split Roller Bearing Corp.

5365 Robin Hood Road | Suite B | Norfolk, VA 23513 | USA

Tel: +1 (1) 757 460 0925 | Fax: +1 (1) 757 464 3067

Email: CoopersalesUS@kaydon.com

UK, Europe, South America, Asia, Australia and the Middle East

Cooper Roller Bearings Company Ltd.

Wisbech Road | Kings Lynn, Norfolk | PE30 5JX | United Kingdom

Tel: +44 (0) 1553 763447 | Fax: +44 (0) 1553 761113

Email: CoopersalesUK@kaydon.com

Germany

Cooper Geteilte Rollenlager GmbH

Postfach 100 423 | Oberbenrader Str.407 | 47704 Krefeld Germany

Tel: +49 (0) 2151 713 016 | Fax: +49 (0) 2151 713 010

Email: CoopersalesDE@kaydon.com

India

Cooper Roller Bearings Company Ltd.

Wisbech Road | Kings Lynn, Norfolk, PE30 5JX | United Kingdom

Tel: +91 (0) 9820180089

Email: CoopersalesIN@kaydon.com

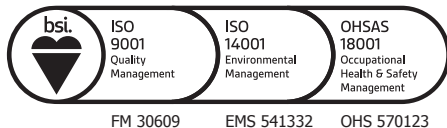

an SKF Group brand

SKF

Visit CooperBearings.com