

## **NKE bearings for industrial gearboxes**

- > Versatile solutions  
for demanding applications

*More possibilities!*

**NKE**  
B E A R I N G S

# Your competent partner for bearings

> Standard and special solutions

## Suitable bearings for your drive system

Loads, speeds, torque, installation space... - there are many factors you have to consider when designing a drive system. Suitable bearings play a decisive role in industrial gearboxes.

Creative technical and commercial solutions, combined with good stock availability as well as short delivery times are the NKE benefits for you.

### Application example:

#### Bearing arrangement of a planetary gearbox



#### Cylindrical roller bearings

- > Suitable for high radial loads and medium to high speeds
- > In floating arrangements



#### Four-point contact ball bearing

- > Radially unrestrained to accommodate thrust loads
- > Limited radial loads, provided that:

$$\frac{F_a}{F_r} \geq 1,27$$

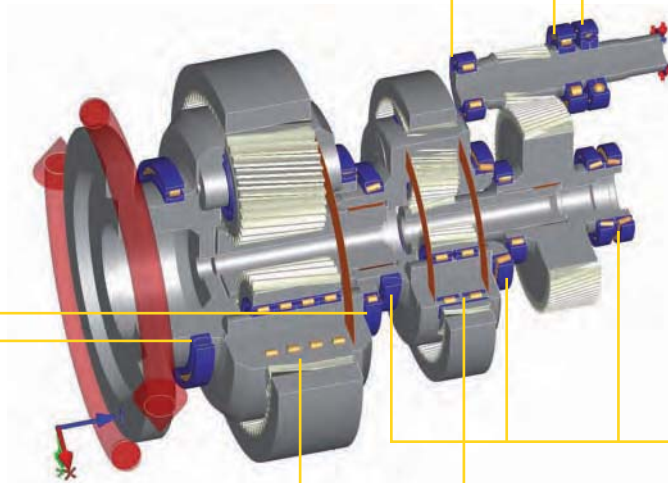

#### Full complement cylindrical roller bearings (without cage)

- > Suitable for very high radial loads
- > Low speed

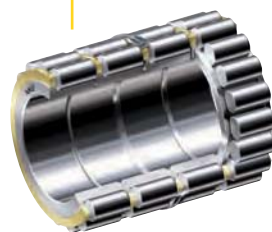

#### Special cylindrical roller bearings

- > Modular system allows for standardisation of planet wheel bearings
- > 2-, 3- or 4-fold sets as required



#### Tapered roller bearings

- > Suitable for high radial loads
- > When paired, can take up thrust loads in both directions Richtungen
- > Custom designs possible

\* For smaller gearboxes NKE deep groove ball bearings and angular contact ball bearings are also used.

## > Professional service support

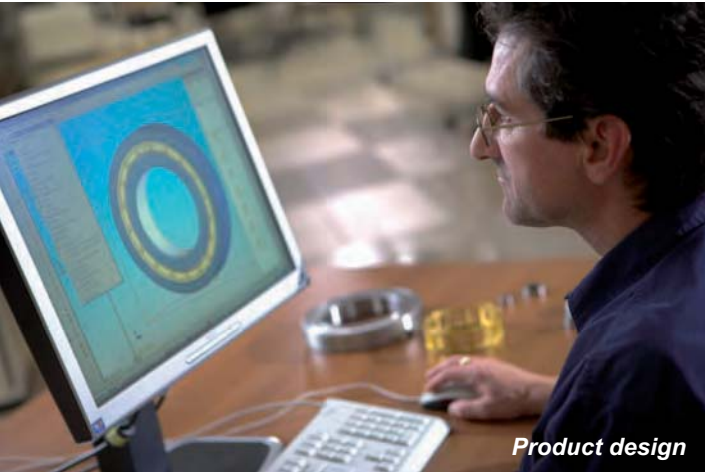

Equipped with experience and know-how, our technical and commercial teams work closely together with our customers. Our services include:

- > Application consultancy
- > Technical calculation
- > Certification support
- > Product development, design support
- > Training

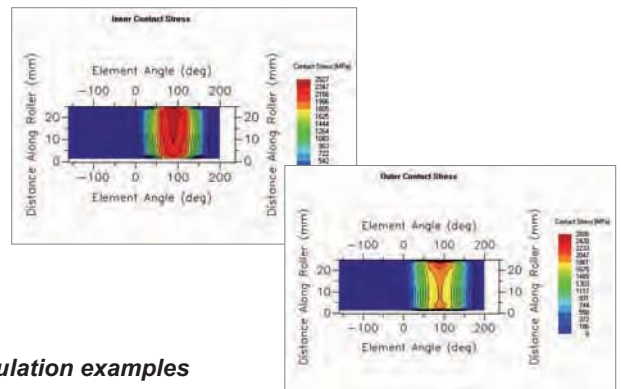
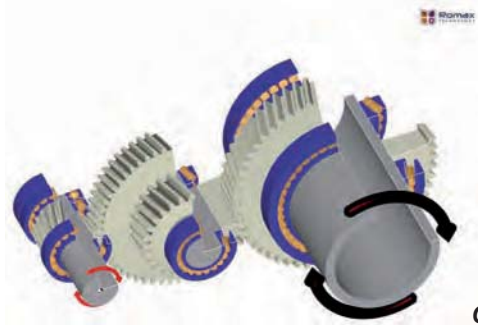

## Applications in various industries

Other NKE bearing applications include:

- > Plant construction
- > Materials handling
- > Railway vehicles
- > Metal production and processing
- > Wind energy
- > Mining and heavy machinery

Ask us for the latest reference list!



**Angle drive for mining equipment**



**Geared hub motor**

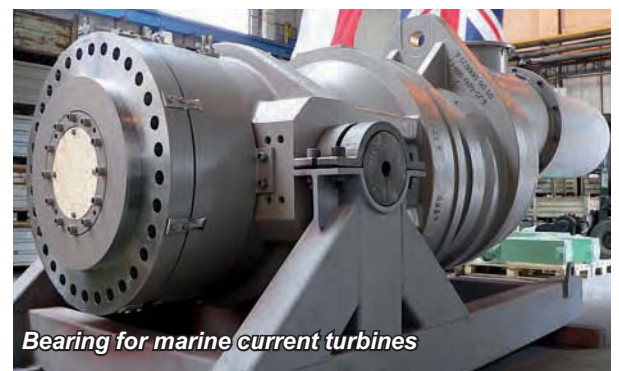

**Bearing for marine current turbines**



NKE headquarters in Steyr – more than 10.000 m<sup>2</sup> for core functions such as engineering, production, logistics, quality assurance, marketing and sales



# NKE AUSTRIA

NKE AUSTRIA GmbH is a premium bearing manufacturer with headquarters in Steyr, Austria. The company was founded in 1996 by a group of senior staff members of the former Steyr Wälzlager.

NKE manufactures both standard and special bearings for all industrial applications. Our core competences – engineering, product development, final processing of components, assembly, quality assurance, logistics, sales and marketing – are centralised in Steyr. The site is accredited with ISO 9001:2008 (design, development, manufacturing and distribution of bearings), ISO 14001:2004 and OHSAS 18001.

For more information please contact:

**NKE**  
B E A R I N G S

**NKE AUSTRIA GmbH**  
Im Stadtgut C4,  
4407 Steyr, Austria  
Tel: +43 7252 86667  
Fax: +43 7252 86667-59  
office@nke.at  
www.nke.at

We offer:

- Standard bearings with a comprehensive stock range
- Tailor-made bearings for special requirements
- Technical service (e.g. consulting, documentation, training etc.)

NKE bearings are distributed through 18 international representative offices and more than 240 distribution outlets in over 60 countries.



Your local NKE partner

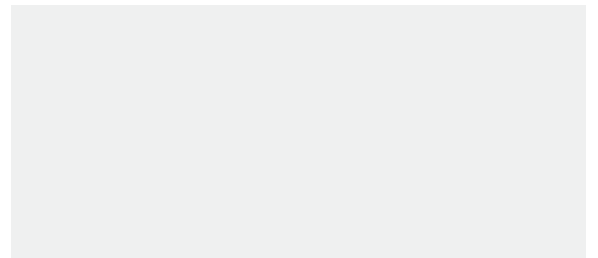

Every care has been taken to ensure the accuracy of the information contained in this publication, but NKE accepts no liability due to errors or omissions NKE reserves the right to change any product specifications. All rights reserved. © NKE Austria GmbH.

Member of:

